

# OREGON OCCUPATIONAL SAFETY AND HEALTH STANDARDS

Oregon Administrative Rules, Chapter 437

## DIVISION 7



Oregon Occupational Safety and Health Division (Oregon OSHA)  
Department of Consumer and Business Services  
Salem, Oregon 97301-3882

AO 2-2014

The Oregon Department of Consumer and Business Services adopted these rules pursuant to ORS 654.025(2).

The Secretary of State Designated OAR Chapter 437 as the "Oregon Occupational Safety and Health Code." Six general subject areas within this code are designated as "Divisions."

- **Division 1** General Administrative Rules
- **Division 2** General Occupational Safety and Health Rules
- **Division 3** Construction
- **Division 4** Agriculture
- **Division 5** Maritime Activities
- **Division 7** Forest Activities
- **Oregon Revised Statutes (ORS)** 654 The Oregon Safe Employment Act (OSEAct)

Oregon-initiated rules in this division of the Oregon Occupational Safety and Health Code are numbered in a uniform system developed by the Secretary of State. This system does not number the rules in sequence (001, 002, 003, etc.). Omitted numbers may be assigned to new rules at the time of their adoption.

**Oregon-initiated rules** are arranged in the following Basic Codification Structure adopted by the Secretary of State for Oregon Administrative Rules (OAR):

Chapter 437	Division 007	Rule 0055	Section (1)	Subsection (a)	Paragraphs (A)(i)(I)
----------------	-----------------	--------------	----------------	-------------------	-------------------------

---

To obtain an order form or copies of these codes, address:

**Department of Consumer & Business Services**  
**Oregon Occupational Safety & Health Division (Oregon OSHA)**  
**350 Winter St. NE, Room 430**  
**Salem, OR 97301-3882**

Or call the Oregon OSHA Resource Library at 503-378-3272

The rules referenced in this division are available for viewing in the Office of the Secretary of State, Administrative Rules and Office Document Section, Oregon State Archives Building, Salem, Oregon 97310, or the Central Office, Oregon Occupational Safety and Health Division of the Department of Consumer and Business Services, Room 430, 350 Winter St. NE Salem, OR 97301-3882. Please visit our web site at: [www.orosha.org](http://www.orosha.org)

## HISTORICAL NOTES:

**NOTE:** Oregon OSHA Administrative Order 5-2003, **filed 6/2/03, effective 12/1/03**, adopted Division 7, Forest Activities, and repealed Division 6, Forest Activities. OR-OSHA proposed Division 7 rules in Fall 2002 and conducted a number of public hearings. Oregon OSHA evaluated public hearings input and written comments to complete the review and revision of the Forest Activities rules. Based on the comments received we have made a number of minor changes in the final standard. There were also changes to the requirements for employer payment for PPE, guarding of machine cabs and first aid training which were necessary to meet our Federal OSHA obligations as a state plan state. The current Division 6, Forest Activities rules are being replaced with a series of forest activities rules and notes in a new Division 7, Forest Activities which:

1. Make rules more clear and concise for users;
2. update rules to include current technology;
3. eliminate outdated/obsolete rules;
4. provide uniformity between Forest Activities rules and other rules;
5. address areas not currently addressed; and
6. satisfies the requirements for periodic rule review.

**NOTE:** Oregon OSHA adopts amendments to existing standards in Division 7, Forest Activities. Many of the changes are in response to a federal mandate to clarify the requirements for: wire rope inspections; and controlling hazardous energy. Additional clarifications are based on industry requests and input from Oregon OSHA's Forest Activities Standard Advisory Committee. After reviewing public hearing comments, Oregon OSHA decided not to adopt the proposed changes to the Medical Services and First Aid (OAR 437-007-0220) rule. However, 437-007-0220(3)(b) is amended to add 'or as required by a nationally recognized first aid training provider.' A program directive has been developed for clarification on the enforcement of these requirements.

This is OR-OSHA Administrative Order 3-2004, **adopted and effective June 7, 2004.**

**NOTE:** Oregon OSHA adopted new rules in Division 7/N, Forest Activities/Wildland Fire Suppression and Prescribed Fire. We repealed OAR 437-007-1391 through 437-007-1399, and adopted 11 new rules in Division 7/N. Also adopted are amendments to 14 existing standards in subdivisions A, B, C, G, J, L, and Appendix 7-C.

All changes have been reviewed by the Forest Activities Advisory Committee and the subcommittee for Wildland Firefighting comprised of representatives from labor, private and government land owners, and government agencies. This group started meeting in February 2003 and remains an active advisory group. These changes clarify existing regulations and keep standards current with updated technology.

This is OR-OSHA Administrative Order 2-2005, **adopted May 27, 2005, effective June 1, 2005.**

**NOTE:** These changes amend Division 7, Forest Activities, Subdivision H, Machines Used in Forest Activities, rules OAR 437-007-0775 and 437-007-0780, which:

1. Extends the implementation date from July 1, 2009, to July 1, 2014 for excavator based machine protective structures required by OAR 437-007-0780.
2. Adopts a new rule, OAR 437-007-0775(15) exempting construction machines from the protective structure requirement if they perform only road construction activities.

This is OR-OSHA Administrative Order 2-2008, **adopted and effective March 5, 2008.**

**NOTE:** These changes repeal OAR 437-007-0685, Climbing Equipment and Climbing, and replace it with a series of new rules and notes contained in Division 7, Forest Activities, Subdivision P which:

1. Make rules clear and concise for users;
2. update rules to include current technology;
3. eliminate outdated/obsolete rules;
4. provide uniformity between Forest Activities rules and other rules; and
5. provide for the development of a climber rescue plan.

OAR 437-007-0025, Definitions, is amended to include definitions associated with Subdivision P, Tree Climbing.

The Worker Protection Standard (WPS) rule, OAR 437-007-0010, is amended to clarify that the WPS in its entirety is a part of Division 7.

This is OR-OSHA Administrative Order 3-2008, **adopted March 7, 2008 and effective July 1, 2008.**

**NOTE:** In Oregon, Oregon OSHA administers and enforces the pesticide Worker Protection Standard (WPS: 40 CFR 170) as adopted in Division 4, Agriculture, Subdivision W, OAR 437-004-6000.

This rulemaking amends OAR 437-004-6000 to reflect non-substantive corrections and technical amendments that were published in the Federal Register from 2006 through 2009.

Oregon OSHA is also amending the pesticide Worker Protection Standard (WPS) in Division 7, Forest Activities, Subdivision A, General Requirements, OAR 437-007-0010, to clarify the references in Division 7 to the WPS in Division 4.

In addition, Oregon OSHA is amending Division 2, General Industry, Subdivision Z, Toxic and Hazardous Substances, by adopting a new rule (OAR 437-002-0170) to clarify that under certain circumstances all parts of the Worker Protection Standard (WPS) apply to general industry workplaces, and are a part of Division 2 in addition to, and not instead of, any other part of Division 2.

Members of the public submitting written comments expressed support for the changes but noted that the proposed amendments (being non-substantive) do not go far enough to improve the protection of Oregon's affected workers from exposure to pesticides. The changes suggested by these commenters were outside the parameters of this rulemaking.

This is Oregon OSHA Administrative Order 9-2009, **adopted and effective September 21, 2009.**

**NOTE:** This rulemaking is to keep Oregon OSHA in harmony with recent changes to Federal OSHA's standards.

Federal OSHA revised the personal protective equipment (PPE) sections of its general industry, shipyard employment, longshoring, and marine terminals standards concerning requirements for eye- and face-protective devices, and head and foot protection.

Federal OSHA updated the references in its regulations to reflect more recent editions of the applicable national consensus standards that incorporate advances in technology. Federal OSHA requires that PPE be safely designed and constructed for the tasks performed.

Amendments to the PPE standards include a requirement that filter lenses and plates in eye-protective equipment meet a test for transmission of radiant energy such as light or infrared.

Oregon OSHA adopted the changes in general industry and maritime activities as published in the September 9, 2009 Federal Register. The updated references are also made in Oregon OSHA's Division 4, Agriculture, and Division 7, Forest Activities.

This is Oregon OSHA Administrative Order 2-2010, **adopted and effective February 25, 2010.**

**NOTE:** This rulemaking exempts machines manufactured prior to July 1, 2004, capable of 360 degree upper structure rotation that are equipped and maintained with a front and top guard structure meeting the performance criteria of the Society of Automotive Engineers' SAE J1356:FEB88 or the International Organization for Standardization ISO 10262:1998 (Level II), from limitations under OAR 437-007-0780, effective July 1, 2014. This rulemaking also corrects a typo in the current rule.

One public hearing was held with three comments received. All comments were favorable to this rulemaking.

Oregon OSHA makes these changes to OAR 437-007-0780 in Division 7/H.

This is Oregon OSHA Administrative Order 2-2014, **adopted and effective May 29, 2014.**



# GENERAL REQUIREMENTS AND DEFINITIONS

# A

## TABLE OF CONTENTS

<b>437-007-0001</b>	Authority of Rules .....	A-1
<b>437-007-0002</b>	Purpose of Rules.....	A-1
<b>437-007-0003</b>	Scope of Rules .....	A-1
<b>437-007-0004</b>	Applicability of Rules .....	A-1
<b>437-007-0010</b>	Worker Protection Standard.....	A-2
<b>437-007-0025</b>	Definitions .....	A-3



**437-007-0001 Authority of Rules.** These rules are promulgated under the Director's authority contained in ORS 654.025(2) and ORS 656.726(4).

**Stat. Auth.:** ORS 654.025(2) and 656.726(4).  
**Stats. Implemented:** ORS 654.001 through 654.295.  
**Hist:** OR-OSHA Admin. Order 5-2003, f. 6/02/03, ef. 12/01/03.

**437-007-0002 Purpose of Rules.** The purpose of the rules contained in this Division is to prescribe minimum safety and health requirements for all employees employed in forest activities work.

**Stat. Auth.:** ORS 654.025(2) and 656.726(4).  
**Stats. Implemented:** ORS 654.001 through 654.295.  
**Hist:** OR-OSHA Admin. Order 5-2003, f. 6/02/03, ef. 12/01/03.

**437-007-0003 Scope of Rules.** The rules in this Division apply to all public and private employers who engage in forest activities as listed in OAR 437-007-0004.

**Stat. Auth.:** ORS 654.025(2) and 656.726(4).  
**Stats. Implemented:** ORS 654.001 through 654.295.  
**Hist:** OR-OSHA Admin. Order 5-2003, f. 6/02/03, ef. 12/01/03.

#### **437-007-0004 Applicability of Rules.**

The rules in Division 7 establish occupational safety and health practices for all forest activity operations including but not limited to:

- Chemical application
- Chipping
- Clearing and slash disposal
- Forest road construction, maintenance and decommissioning
- Log dumps, ponds, plantsite log yards and independent sort yards
- Log hauling
- Marking
- Prescribed fire
- Pulpwood and non-pulpwood logging
- Reforestation/vegetation management
- Stream restoration
- Timber cutting and thinning operations
- Timber cruising
- Tree climbing activities
- Wildland fire suppression

Any situation or condition not specifically addressed will be subject to other applicable provisions of the Oregon Administrative Rules, Chapter 437, Oregon Occupational Safety and Health Standards.

**Stat. Auth.:** ORS 654.025(2) and 656.726(4).  
**Stats. Implemented:** ORS 654.001 through 654.295.  
**Hist:** OR-OSHA Admin. Order 5-2003, f. 6/02/03, ef. 12/01/03.  
OR-OSHA Admin. Order 2-2005, f. 5/27/05, ef. 6/1/05.

<b>A</b>	<b>WORKER PROTECTION STANDARD</b>	Oregon Administrative Rules Oregon Occupational Safety and Health Division
----------	---------------------------------------	--

**437-007-0010 Worker Protection Standard.** Oregon OSHA administers and enforces the Worker Protection Standard (40 CFR 170) as adopted in OAR 437-004-6000 in Division 4/W. All parts apply without regard to the scope of Division 4 in addition to, and not instead of, any other part of Division 7, Forest Activities. Should any of the parts of these two standards conflict, comply with the part offering the most protection to workers.

**Stat. Auth.:** ORS 654.025(2) and 656.726(4).  
**Stats. Implemented:** ORS 654.001 through 654.295.  
**Hist:** OR-OSHA Admin. Order 5-2003, f. 6/02/03, ef. 12/01/03.  
OR-OSHA Admin. Order 3-2008, f. 3/7/08, ef. 7/1/08.  
OR-OSHA Admin. Order 9-2009, f. 9/21/09, ef. 9/21/09.

**437-007-0025 Definitions.** The following definitions apply to terms used in this Division:

**A-frame** – A structure made of two independent columns fastened together at the top and separated by a reasonable width at the bottom to stabilize the unit from tipping sideways.

**Alternative communication system** – A system by voice, hand or media other than horn or whistle which provides a safe and reliable method of communication between crew members.

**Anchor point** (tree climbing) – A secure point capable of providing life support.

**Approved container** – A metal or polyethylene (plastic) container that can be used to carry flammable liquids in quantities up to 5 gallons. These containers must be accepted as satisfactory to contain flammable liquids by a nationally recognized testing lab, such as Underwriters Lab (UL) or Factory Mutual (FM).

**Aramid** – The generic name for a high-strength, flame-resistant synthetic fabric used in the shirts and jeans of firefighters. Nomex, a brand name for aramid fabric, is the term commonly used by firefighters.

**Arch** – Any device attached to the back of a mobile vehicle and used for raising one end of logs to facilitate movement.

**Ascenders** (Jumars, Gibbs) – Any climbing device used to ascend a fixed vertical rope. The term ascenders usually refers to mechanical devices.

**Authorized person** – See “Designated Person.”

**Backcut** (falling cut) – The cut opposite of the face cut.

**Ballistic nylon** – A nylon fabric of high tensile properties designed to provide protection from lacerations.

**Base of tree** – That portion of a tree that is not more than 12 inches above highest ground level.

**Belay** (snubbing) – A method of protecting a climber in case of fall. A safety rope tied to a climber is paid out or taken in as the climber moves by a second person (the belayer) or by the climber in a self-belay (using the 4-inch tie-in). By controlling the safety rope, the belayer can stop the climber from falling.

**Below the four-inch bole diameter** – Any point on the bole of the tree where the diameter is greater than 4 inches.

**Bight of the line** – A hazardous zone created by one or more lines under tension, or a point on a line where a rigging chain is attached.

**Binder** – A hinged lever assembly for connecting the ends of a wrapper to tighten the load restraining devices (log trucks, flatbeds, lowboys, etc.).

**Brow log** – A log placed parallel to any roadway at a landing or dump to protect carriers while loading or unloading.

**Buck** – To cut a fallen tree into logs.

**Butt** – The bottom cut or the first log of a fallen tree.

**Cable yarding** – The movement of trees or logs from the area where they have been fallen to a landing by attaching them to a cable system that is supported by a metal tower (wood spar) and/or intermediate support or tail trees.

**Carabiner** (Biners, Locking Carabiners) – An oblong metal ring with a spring loaded gate on one side used for various purposes in climbing, such as attaching equipment to the climber or securing the climber to a rappel system.

**Chest harness** – Straps placed around the chest and shoulders only to secure the proper positioning for a chest attachment point.

**Chock** – A block, often wedge-shaped, which is used to prevent movement; for example, a log from rolling, a wheel from turning.

**Choker** – Length of wire rope, chain or synthetic material with attachments for encircling a log to be yarded.

**Climber** – A person qualified to climb a tree; the person climbing.

**Climbers belt** (Lineman's Belt, Body Belt, Safety Belt) – A wide padded belt having two large metal D-ring attachment points on the sides. A climbing belt does not have an attached chest harness or attached leg straps.

**Climbing harness** – A type of harness that provides both pelvic and upper body support and can be adjusted to fit individual climbers. Climbing harnesses may be a one-piece design (full body harness) or any two-piece design that meets industry recognized standards. Climbing harnesses normally have separate leg loops. Tree climbing harnesses will usually have all of the above plus two large D-ring attachment points on the sides.

**Climbing helmet** – Designed specifically for climbing, this helmet has a three-point chinstrap and is designed to remain in place during a fall. It is rated for the helmet's ability to protect against side and top impacts.

**Climbing line** – A 5400 pound minimum breaking strength rope used in tree climbing for ascending into a tree, descending from a tree, and/or working aloft in a tree.

**Climbing spurs** (Climbers, Tree Climbers, Gaffs, Pole Gaffs, Spurs, Tree Spurs, Lineman's Climbers, Spikes) – L-shaped metal shanks that attach to the foot and lower leg and are used to ascend or descend a tree bole by means of a sharp spike (gaff) that penetrates the tree bark and sticks into the wood of the tree.

**Competent person** – A qualified person who has been authorized by the employer or employer representative to:

(a) Identify existing and predictable hazards in the surroundings or working conditions which are hazardous or dangerous to employees, and

(b) Eliminate the hazard or take corrective action.

**Confine a fire** – To restrict the fire within determined boundaries established either prior to the fire or during the fire.

**Contain a fire** – To take suppression action, as needed, which can reasonably be expected to check the fire's spread under prevailing conditions.

**Control a fire** – To complete control line around a fire, and spot fires therefrom and any interior islands to be saved; burn out any unburned area adjacent to the fire side of the control lines; and cool down all hot-spots that are immediate threats to the control line, until the lines can reasonably be expected to hold under foreseeable conditions.

**Cut-up-tree/snag** – A tree/snag, left standing, with the falling cuts started or completed.

**Cutter** – One whose primary job is to manually fall, buck or limb trees.

**Danger tree** – A standing tree, alive or dead, that presents a hazard to personnel due to deterioration or physical damage to the root system, trunk (stem), or limbs, and the degree and direction of lean.

**DBH** – Diameter at breast height.

**Deadman** – Buried log or other object used as an anchor.

**Deck** – A stack of trees or logs.

**Descenders** – Any rappelling device used to descend a vertically fixed rope.

**Designated person** – An individual who has been assigned by the employer or the employer representative to perform a specific duty or duties.

**Direct supervision** – Supervision by a competent person who watches over and directs the work of others who are within sight and unassisted natural voice contact.

**NOTE:** Direct supervision may be achieved by radio contact when an untrained runner is enroute to or from an operational area where there may be exposure to wildland fire hazards, provided there is a competent person at both the pick-up and drop-off points.

**Domino falling** – The partial cutting of several trees which are left standing and then pushed over with a pusher (driver) tree. This definition of domino falling does not include the falling of:

(a) A single danger tree by falling another single tree into it.

(b) Two or more trees at the same time because their limbs are interlocked.

**Double tree intermediate support system** – A system for supporting a loaded skyline in a support jack suspended on a single piece of wire rope that is supported by two trees in a manner that provides for sharing the load between the two trees. (See Figure 7-15.)

**Dress a knot** – To orient the rope parts of a knot so they are properly aligned, straightened, or bundled. This is often necessary for proper operation of the knot or to reduce rope stress.

**Dutchman** (as used in falling) – A method used to pull a tree against its lean by leaving a section of the undercut on one corner of the face.

**Dutchman** (as used in yarding) – A block used to change direction of line lead (sideblocking).

**Dynamic rope** – A rope that has an elongation of 40 to 60 percent at the breaking strength and typically a 2 to 8 percent elongation at a working load of 200 pounds.

**Emergency care** – Care provided by a person who is first aid and CPR trained.

**Emergency medical service** – Care provided by a medically trained person such as in a hospital, clinic, ambulance or rescue vehicle.

**Emergency scene** -The site where the suppression or control of a fire or an emergency exists.

**Equipment** – See “Vehicle and Machine.”

**Equipment protection designations** – The listing of specific guarding requirements for specific logging machines.

**Escape route** – A planned and understood route firefighters take to move to a safety zone or other low-risk area.

**Experienced person** – A person who has sufficient training, experience and skill in a given process to be knowledgeable of all aspects of that process.

**Extreme weather conditions** – Includes, but not limited to:

(a) Strong winds (applies to timbered areas only) – Wind velocity that reaches sufficient force to blow limbs from standing trees, cause windfalls, or prevent cutters from falling trees in the desired direction;

(b) Impaired vision – Conditions such as falling snow, sleet, mist, fog, rain, dust, or darkness which substantially impairs visibility to the extent that employees cannot clearly see signals, moving vehicles, equipment and lines, falling trees or other hazards;

(c) Hazardous snow or ice conditions – Snow or ice conditions which prevent escape from hazards such as falling trees, moving logs, vehicles, or similar hazards; or

(d) Lightning.

**Fairlead** – Sheaves, rolls or a combination thereof arranged for receiving a line coming from any direction to minimize the line from burning and aid proper line spooling onto a drum.

**Fall** – To cut down trees.

**Faller** – A person who falls (cuts down) trees.

**Fire camp** – A geographical site(s) equipped and staffed to provide sleeping, food, water and sanitary services to fire personnel.

**Fire fighting equipment** – All portable and fixed fire suppression and control equipment.

**Fire season** – That period during the year when the State Forester declares fire season in any part of the state, as required by ORS 477.505.

**Fire shelter** – A personal protection item carried by firefighters which when deployed unfolds to form a pup-tent shelter of heat reflective materials.

**Firefighter** – Any employee whose primary duty is fire suppression and control of fires on or around wildland areas.

**Flame resistance** – The property of material, or combinations of component materials, to retard ignition and restrict the spread of flame.

**FOPS** (Falling Object Protective Structure) – Structural members arranged in such a way to reasonably protect operators from falling objects such as trees, rocks, etc.

**Four-inch tie-in** – A self-belay (snubbing) system usually consisting of a rope, webbing, and carabiners. It is used as a safety line to secure the climber to the tree below the 4-inch bole diameter and at 3-foot intervals along the bole when climbing above the 4-inch bole diameter.

**Frequent review or inspection** – A review or inspection that is conducted at intervals which are necessary (conducted on daily to monthly intervals) to gain a desired assessment of conditions, practices, policies or procedures.

**Grounded (Cutting)** – Placement of a tree on the ground.

**Grounded (Electrical)** – A method to dissipate static or electrical charges.

**Grounded (Machines)** – The placement of a machine component on the ground or device where it is firmly supported.

**Guarded** – Covered, shielded, fenced, enclosed, or otherwise protected by means of suitable enclosures, covers, casings, shields, troughs, railings, screens, mats, or platforms, or by location to prevent injury.

**Guyline** – A standing line used to support or stabilize a spar, tail tree, intermediate support tree, machinery or equipment.

**Health care provider** – A health care practitioner operating within the scope of their license, certificate, registration, or legally authorized practice.

**High lead** – A system of logging where the mainline is threaded through the mainline block which is located near the top of the spar or metal tower to obtain a lift of the logs being yarded and is returned to the vicinity of the logs by a haulback line.

**High visibility colors** – Bright or fluorescent white, lime green, orange, yellow, red, or aqua colors that stand out from the surrounding background color so as to make them easily seen.

**In the clear** – A position within the work area where the probability of hazardous contact with vehicles, machines, falling trees, moving logs, rootwads, chunks, material, rigging, and equipment is minimized by distance from the hazards and/or use of physical barriers, such as stumps, trees, terrain, or other objects providing protection.

**Initial attack** – The control efforts taken by all resources which arrive at the fire during the first burning period (first 24 hours).

**Kicker** (as used in cutting) – A piece of the face, or an equivalent object, placed in one side of a face cut to pull the tree from its lean as it falls.

**Landing** – Any designated place where logs are laid after being yarded and are awaiting subsequent handling, loading and hauling.

**Landing chute** – The head of the skid trail or yarding road where the logs are temporarily placed and are awaiting subsequent handling, loading, and hauling.

**Lanyard** (Climbing rope, Safety Lanyard, Adjustable Lanyard, Prusik Lanyard, Flip Line) – A short piece of 5400 pound minimum breaking strength rope or webbing that secures the climber to the tree.

**Lay** (cutting) – The desired direction of fall for a tree.

**Lay** (wire rope) – A unit of measure to describe the straight-line distance in which a strand of wire rope makes one complete spiral around the core of a rope. The way wires have been laid to form strands and the way strands have been laid around the core (i.e., regular, lang lay, etc.).

**Life support line** (rope) – Any 5400 pound minimum breaking strength line, such as but not limited to, a climbing rope, flip strap or lanyard used to support or secure a climber in a tree.

**Limbing** – To cut branches off trees.

**Lodged tree** (hung tree) – A tree leaning against another tree or object which prevents it from falling to the ground.

**Log** – A segment sawed or split from a fallen tree, such as, but not limited to, a section, bolt, or tree length.

**Log dump** – An area in which logs are removed from a truck or rail car. May be either dry land or water, parbuckled over a brow log or removed by machine.

**Logging** – All operations relating to the falling of trees, cutting the fallen trees into suitable lengths, yarding, limbing, debarking, grading, loading, hauling, unloading, storing in decks or ponds until processed from timber to wood products.

**Machine** – Equipment used or intended for use in forest activities operations such as but not limited to building or maintaining roads; felling trees; processing trees or fiber; yarding, moving or handling logs, trees, chunks and other material; stream restoration; forest operations for wildlife enhancement or other management objectives; and wildland fire suppression.

**Mainline** (yarding) – The line that moves the turn of logs toward the yarder in any given system.

**Mechanized falling** – Falling of standing timber by a self-propelled mobile-wheeled or tracked machine equipped with a shear or other powered cutting device.

**Metal tower** – A vertical or leaning metal tube or boom used for yarding logs by various methods of cable logging.

**NRTL** (Nationally Recognized Testing Laboratory) – An organization which is recognized by OSHA in accordance with OAR 437, Division 2/A, §1910.7, Appendix A, OSHA Recognition Process for Nationally Recognized Testing Laboratories.

**OPS (Operator Protective Structure)** – Structures or enclosures whose primary purpose is to minimize the possibility of operator injury from hazards, such as whipping saplings, branches, jill-poking and snapping winch lines with the least adverse effect on operator visibility, comfort, and protection from other hazards. Specific standards and tests exist and are referenced in many national and state codes.

**Pass line** – A small line threaded through a block at or near the top of a wood tree or metal tower to assist the high climber.

**Periodic review or inspection** – A review or inspection that is conducted at predetermined intervals (conducted on 1 to 12 months intervals).

**Personal protective equipment** – Clothing or equipment worn to protect the head, body, feet and extremities from chemical or physical hazards.

**Potential failure zone** – An area that could be impacted by the failure of any part of a standing tree anchor, tail or intermediate support tree as the result of forces or loads imposed on the tree by guylines, running lines or skylines. The boundaries of the zone encompass the area into which the tree, or parts of the tree, could fall, slide or roll and all trees, logs, lines and material impacted by the tree failure.

**Prescribed fire** – Any fire burning under predetermined conditions to meet specific objectives related to fuels reduction or habitat improvement.

**Qualified first aid person** – Has evidence to show valid first aid and CPR training within the last 2 years.

**Qualified person** – A person who has:

(a) A recognized degree, certification, professional standing, knowledge, training or experience.

(b) Successfully demonstrated the ability to perform the work, solve or resolve problems relating to the work, subject matter, or project.

**Qualified tree climber** – An individual having the physical capabilities, training, work experience and job assignment authorized by the employer to climb tree.

**Rappel rope (main line, prusik rope, descent rope)** – A 5400 pound minimum breaking strength rope used to rappel or descend from a tree.

**Rated capacity** – The load identified by the manufacturer that a system, vehicle, machine or piece of equipment can lift or move.

**Reach** – Usually a rectangular steel tube which slides in the trailer tunnel and is used as a connection between a log truck and the trailer.

**Reforestation** – All forest management operations relating to the planting and nurturing of trees. The nurturing of trees includes: fertilization, pre-commercial thinning, mulching, pruning, animal control measures, application of chemicals, and stand inventories.

**ROPS (Roll-Over Protective Structure)** – Framing and support for machinery that reduces the possibility of a seat belted operator from being crushed should the machine roll over. Specific standards and tests exist and are referenced in many national and state codes.

**Root wad** – The root ball and dirt that is pulled from the ground when a tree or stump is uprooted.

**Rub rails** – Guarding on the exposed sides of elevated bridges, ramps or runways to prevent wheeled equipment from going over the edge.

**Rub tree** – A tree used to guide a turn around a certain area.

**Runner** – A person who delivers supplies, materials or relays information.

**Running line** – Any moving line in a cable yarding system.

**Saddle (sit harness)** – A type of work harness specifically designed to support the climber for long periods in a sitting position. A saddle differs from a safety harness by not having a chest component and may have either two separate leg loops or a single wide strap that encircles the climber below the buttocks.

**Safety factor** – The ratio of breaking strength to safe working strength or load.

**Safety line (safety rope, belay rope)** – A 5400 pound minimum breaking strength rope that is either attached to a climber and used for belaying by a ground person or is attached to an anchor point and adjusted by the climber (such as with the 4-inch tie-in).

**Safety pin (shackle)** – A threaded shackle pin secured by a nut that is secured with a cotter key, latchpin or molly.

**Safety strap (sling)** – A length of rope or webbing used as a protection point in a belayed ascent by either the ground person or the climber in a self-belay (as in the 4-inch tie-in). These straps are placed around the tree bole and secured by either a knot or carabiner, then secured to the belay rope with a carabiner.

**Safety swede** – A device that is designed for the specific purpose of making a positive connection to binders that are being closed (tightened) or opened.

**Safety Zone (fire)** – A designated area of sufficient size and suitable location that is expected to protect fire personnel from known hazards without using fire shelters, such as but not limited to an already burned area, previously constructed safety area, a meadow that won't burn, manmade or natural rocky area that is large enough and sufficiently devoid of fuels to take refuge without being burned.

**Secured** – When the climber is safeguarded from unintended movement utilizing a climbing system that is attached to the climber and connected to the tree. Examples of being secured include, but are not limited to: (1) when tied in (2) when using a lanyard (3) when on belay (4) when ascending a climbing line using the footlock technique while utilizing a Prusik loop or ascenders.

**Serviceable condition** – That quality of a tool, machine, vehicle, equipment, or other device to operate as it was intended to operate by the manufacturer.

**Short log (chunks)** – Any log or fiber less than 27 feet long.

**Single jack** – One cutter, in an area or portion of standing timber, who falls and bucks.

**Single tree intermediate support system** – A system for supporting a loaded skyline in a support jack suspended from a single tree. The tree may be an upright single-rooted tree or a leaning tree severed or partially severed from the stump.

**Siwash (intentional)** – The use of a natural physical object, such as a tree or stump, that changes the direction of a line rather than with a block.

**Siwash (unintentional)** – When a line is incorrectly routed through standing timber or other objects or, as often occurs in side-hill yarding, the turn of logs pulls the bight of the line downhill and it hangs up on a stump, root wad or other object, changing the lead and creating a hazardous area.

**Skidder** – A self-propelled machine, of the wheel or crawler design, or an animal used to move logs or trees to a landing.

**Skidding** – The movement of logs or fiber on the surface of the ground toward the place where they can be further processed or loaded.

**Skyline** – The line which is hung between two or more supports on which a carriage or block travels.

**Slackline** – A system of logging where a carriage travels on a skyline that can be raised or lowered. The carriage is pulled to the landing by the mainline (skidding line) and is returned to the vicinity of the logs by the haulback line or gravity.

**Slash burning** – The use of prescribed fire as a method of forest management.

**Slope (grade)** – The increase or decrease in altitude over a horizontal distance expressed as a percentage. For example, change of altitude of 20 feet (6 m) over a horizontal distance of 100 feet (30 m) is expressed as a 20 percent slope.

**Snag** – Any standing dead tree or portion thereof.

**Snap Catch** (rope snap, snap link, snap hook) – A metal device with a ring on one end that usually attaches permanently to a rope or cable. The other end has a spring-loaded, locking gate. As opposed to a carabiner, the gate on a snap link does not lock into the body of the snap link and does not offer any additional strength when closed.

**Snubbing** – Retarding or controlling the movement of logs or machines by attachment to another vehicle or stationary object.

**Spring pole** – A tree, segment of a tree, limb, or sapling which is under stress or tension due to the pressure or weight of another object.

**Square lead** – A horizontal angle of up to 90 degrees formed by the projected lines of the mainline from the drum of the logging machine through the block or fairlead and the yarding road.

**Stability** (machine or vehicle) – The capacity of a machine or vehicle to return to equilibrium or to its original position after having been displaced.

**Steel-core lanyard** (climbing rope, flip rope, spur rope, cable-core lanyard) – A manila or synthetic rope with a steel cable core in which a snap hook or eye has been spliced at one end. This rope is used as a lanyard when spur climbing and when cutting, trimming, or pruning in a tree.

**Strip** – A stand of timber or area of fallen and bucked timber in a predetermined location on which employees work in a planned pattern.

**Supervisory personnel** – Agent of the employer (such as a manager, superintendent, foreperson, hooktender, rigging slinger, or person in charge of all or part of the place of employment) who directs the work activities of one or more employees.

**Swede connection** – A line configuration consisting of wrapping two choker lines in the same direction around a tree or log and connecting the line nubbins to opposite line bells.

**Swing cut** – A back cut in which the holding wood on one side is cut through.

**Swing radius (machines)** – Is that distance equal to actual working radius of machines capable of upper structure rotation plus the length of the attachments, logs, and materials being handled.

**Tail hold** – An anchor used for making fast any line or block other than a guyline.

**Tail tree** – The tree at the opposite end from the landing area on which rigging is hung.

**Tight line** – When a force is exerted on both main line and haulback at the same time.

**Timber cutting** – The falling and/or bucking of trees by hand or mechanical means.

**Topping** – Cutting off the top section of a standing tree prior to rigging the tree for a spar or tail tree.

**TOPS** (Tip-Over Protective Structure) – Framing and support for machinery that reduces the possibility of a seat belted operator from being injured should the machine tip over on its side. Specific standards and tests exist and are referenced in many national and state codes.

**Tractor** – A self-propelled machine of wheel or crawler design used to exert a push or pull force through mounted equipment to move objects or material.

**Tree bole** (bole, tree stem, tree trunk) – The main vertical part of a tree.

**Tree climber trainee** – An individual who is receiving training and on-the-job instruction from a qualified tree climber.

**Tree climbing work** – Any task performed in or on a tree where access is accomplished by means of unsecured climbing, friction knots or mechanical ascenders, bole gripping systems, permanently or temporarily mounted steps, stacked sectional ladders, vehicle or machine hoisting, or climbing spurs.

**Tree jack** (shoe) (other than for directional falling use) – A grooved saddle of wood, soft metal or rollers contained within two steel side plates attached to a tree with a strap as a guide for a skyline, sail guy or similar static line.

**Tree plates** – Steel bars sometimes shaped as elongated “J”s which are fastened to a tree to hold the guylines and prevent the rigging from cutting into the tree when tightened. The hook of the “J” is also used to prevent the mainline block strap from sliding.

**Turn** – Any log or group of logs or other material usually attached by chokers, grapples or other means and moved from a point of rest to the landing or landing chute area.

**Undercut** (face) – A notch cut in a tree to guide the direction of the tree fall and help prevent splitting or kickback.

**V-lead** – A horizontal angle of less than 90 degrees formed by the projected lines of the mainline from the drum of the logging machine through the block or fairlead and the yarding road.

**Vehicle** – A car, bus, truck, trailer or semi-trailer owned, leased or rented by the employer that is used for transportation of employees or movement of material. Any carrier that is not manually propelled.

**Watcher/Firewatch** – A person who visually observes the area on which operation activity occurred for the out-break of fire.

**Wildland Fire** – Any non-structure fire, other than prescribed fire, that occurs in the wildland.

**Wildlands fire fighting** – All activities, operations, and equipment of employers and employees involved in the suppression or control of fires on wildlands. Does not include interior structural fire suppression or control.

**Wildlife tree** – A live, partially dead, or snag tree in the forest riparian zone, or in a cutting unit that is left for wildlife habitat. May also be a danger tree.

**Winching** – The winding of cable or rope onto a spool or drum.

**Within the stakes** – When the log center is below the top of the stakes.

**Work area** – Any area frequented by employees in the performance of assigned or related duties.

**Wrapper (tie down)** – A chain, cable, steel banding, synthetic rope or fiber webbing assembly used to contain a load of logs.

**Yarder** – A machine with a series of drums used to yard logs.

**Yarding** – Movement of logs or trees from the place they were felled to an area where they can be further processed.

**Stat. Auth.:** ORS 654.025(2) and 656.726(4).

**Stats. Implemented:** ORS 654.001 through 654.295.

**Hist:** OR-OSHA Admin. Order 5-2003, f. 6/02/03, ef. 12/01/03.

OR-OSHA Admin. Order 2-2005, f. 5/27/05, ef. 6/1/05.

OR-OSHA Admin. Order 3-2008, f. 3/7/08, ef. 7/1/08.

**A**

Oregon Administrative Rules  
Oregon Occupational Safety  
and Health Division

# **SAFETY AND HEALTH PROGRAM**

# **B**

## **TABLE OF CONTENTS**

<b>437-007-0100</b>	Safety and Health Program.....	B-1
<b>437-007-0105</b>	Management Commitment.....	B-1
<b>437-007-0110</b>	Supervisory Responsibilities .....	B-1
<b>437-007-0125</b>	Accident Investigation .....	B-3
<b>437-007-0130</b>	Employee Involvement.....	B-3
<b>437-007-0135</b>	Hazard Identification and Control .....	B-4
<b>437-007-0140</b>	Training .....	B-5
<b>437-007-0145</b>	Annual Program Evaluation .....	B-6
<b>437-001-0700(21)</b>	Reporting Fatalities and Hospitalization to Oregon OSHA.....	B-7
<b>437-001-0053</b>	Preserving Physical Evidence at the Scene of an Accident.....	B-8

<b>B</b>		Oregon Administrative Rules Oregon Occupational Safety and Health Division
----------	--	--

# SAFETY & HEALTH PROGRAM / MANAGEMENT COMMITMENT / SUPERVISORY RESPONSIBILITIES

# B

**437-007-0100 Safety and Health Program.** Every employer must implement a written safety and health program that establishes management commitment, supervisory responsibilities, accident investigation, employee involvement, hazard identification, training, and annual evaluation of the program.

**Stat. Auth.:** ORS 654.025(2) and 656.726(4).

**Stats. Implemented:** ORS 654.001 through 654.295.

**Hist:** OR-OSHA Admin. Order 5-2003, f. 6/02/03, ef. 12/01/03.

**437-007-0105 Management Commitment.** The employer must:

- (1) State the purpose of the safety and health program.
- (2) Identify the safety and health personnel and resources that will be used to implement the program.
- (3) Establish a labor and management policy that provides for ongoing evaluation of employees' safety performance.
- (4) Establish a disciplinary policy to address unsafe work practices.
- (5) Assign the responsibility, authority and accountability for worker safety and health to all employees who supervise or direct work activity.
- (6) Authorize a competent person(s) for each jobsite who has the authority to:
  - (a) Supervise all personnel at the site.
  - (b) Enforce the company's safety and health program.

**Stat. Auth.:** ORS 654.025(2) and 656.726(4).

**Stats. Implemented:** ORS 654.001 through 654.295.

**Hist:** OR-OSHA Admin. Order 5-2003, f. 6/02/03, ef. 12/01/03.

**437-007-0110 Supervisory Responsibilities.** The employer or their authorized representative must:

- (1) Supervise all employees at the site and enforce the company's safety and health program.
- (2) Verify that all current and new employees:
  - (a) Can safely perform assigned work tasks.
  - (b) Have received adequate job safety instruction and training.
- (3) Periodically review the safety performance of each employee.

**B****SUPERVISORY  
RESPONSIBILITIES**Oregon Administrative Rules  
Oregon Occupational Safety  
and Health Division

**(4)** Provide job safety and health instruction, training or disciplinary action to an employee when the employee is working in an unsafe manner.

**NOTE:** This training can be limited to the specific information needed to correct the unsafe work practice(s).

**(5)** Closely supervise each employee who is receiving job safety and health instruction and training.

**(6)** Require all employees to demonstrate the ability to safely perform their work task before permitting them to work independently.

**Stat. Auth.:** ORS 654.025(2) and 656.726(4).

**Stats. Implemented:** ORS 654.001 through 654.295.

**Hist:** OR-OSHA Admin. Order 5-2003, f. 6/02/03, ef. 12/01/03.

# ACCIDENT INVESTIGATION / EMPLOYEE INVOLVEMENT

# B

**437-007-0125 Accident Investigation.** The employer or their authorized representative must:

- (1) Investigate every employee fatal and recordable injury/illness to determine the cause(s).
- (2) Discuss “near misses” with employees.
- (3) Identify the measures to prevent recurrence of the “near misses,” fatal and recordable injury/illness.
- (4) Inform all employees of the preventive measures resulting from investigations.
- (5) Take steps to prevent recurrence of similar “near misses,” fatal and recordable injury/illness.
- (6) Keep written results of the fatal and recordable injury/illness investigations and corrective measures for 3 years.

**Stat. Auth.:** ORS 654.025(2) and 656.726(4).

**Stats. Implemented:** ORS 654.001 through 654.295.

**Hist:** OR-OSHA Admin. Order 5-2003, f. 6/02/03, ef. 12/01/03.

**437-007-0130 Employee Involvement.** The employer or their authorized representative must:

- (1) Encourage employees to participate in site planning and the pre-work safety meeting to discuss site conditions and known hazards.
- (2) Require employees to report safety and health hazards.
- (3) Require qualified employees to take corrective action and eliminate hazards.
- (4) Conduct monthly safety meetings with all employees.
  - (a) Keep written minutes and attendance records for 3 years.
  - (b) Make written minutes and attendance records available to all employees.

**NOTE 1:** Meetings may be with individuals, separate crews, or larger groups.

**NOTE 2:** Upon written application, OR-OSHA may approve an innovative method to comply with the requirements for monthly safety meetings.

**Stat. Auth.:** ORS 654.025(2) and 656.726(4).

**Stats. Implemented:** ORS 654.001 through 654.295.

**Hist:** OR-OSHA Admin. Order 5-2003, f. 6/02/03, ef. 12/01/03.

OR-OSHA Admin. Order 2-2005, f. 5/27/05, ef. 6/1/05.

**B****HAZARD IDENTIFICATION  
AND CONTROL**Oregon Administrative Rules  
Oregon Occupational Safety  
and Health Division

**437-007-0135 Hazard Identification and Control.** The employer or their authorized representative must:

- (1) Implement a procedure for monthly safety inspections of all worksites, vehicles, machines, equipment, and work practices.
- (2) Identify who will complete monthly safety inspections.
- (3) Implement procedures that will be used to report and correct hazardous conditions.

**Stat. Auth.:** ORS 654.025(2) and 656.726(4).

**Stats. Implemented:** ORS 654.001 through 654.295.

**Hist:** OR-OSHA Admin. Order 5-2003, f. 6/02/03, ef. 12/01/03.

**437-007-0140 Training.** The employer or their authorized representative must:

**(1)** Provide job safety and health instruction and training to current and new employees, including supervisors, that is adequate for the work task. They must receive training before:

- (a)** Starting their initial work assignment, or
- (b)** Being assigned new work tasks, tools, equipment, machines, or vehicles.

**(2)** Evaluate each employee who has previously received job safety and health instruction and training.

**NOTE:** An employee does not need to be retrained if their prior instruction and training are adequate.

**(3)** Provide job safety and health instruction and training that includes the:

- (a)** Safe performance of assigned work tasks.
- (b)** Procedures, practices and requirements of the employer's work site.
- (c)** Recognition of safety and health hazards associated with each employee's specific work tasks, including measures and work practices to prevent or control those hazards.
- (d)** Safe use, operation and maintenance of tools, equipment, machines and vehicles each employee uses or operates, including following the manufacturer's operating and maintenance instructions, warnings and precautions.
- (e)** Requirements of this standard and hazards of the industry.

**(4)** Require each employee receiving job safety and health instruction and training to:

- (a)** Work under the close supervision of a qualified person.
- (b)** Demonstrate to the employer or his authorized representative the ability to safely perform the work assignment before they are permitted to work independently.

**(5)** Assure that a qualified person(s) presents the job safety and health instruction and training.

**(6)** Assure that job safety and health instruction and training is:

- (a)** Presented in a language and manner that the employee(s) is able to understand.
- (b)** Appropriate in content for the skill level of the employee(s) being trained.

**B****TRAINING / ANNUAL  
PROGRAM EVALUATION**Oregon Administrative Rules  
Oregon Occupational Safety  
and Health Division

(7) Keep a current written record of job safety and health instruction and training for each employee that contains the following:

- (a) Who was instructed or trained.
- (b) The date(s) of the instruction or training.
- (c) A description of the training.
- (d) The name of the trainer.

**Stat. Auth.:** ORS 654.025(2) and 656.726(4).

**Stats. Implemented:** ORS 654.001 through 654.295.

**Hist:** OR-OSHA Admin. Order 5-2003, f. 6/02/03, ef. 12/01/03.

**437-007-0145 Annual Program Evaluation.**

- (1) Each employer must review and evaluate their safety and health program annually.
- (2) The program evaluation must include the methods and procedures used to identify and revise program deficiencies.
- (3) Written findings of the annual evaluation must be maintained for 3 years from the date of issue.

**Stat. Auth.:** ORS 654.025(2) and 656.726(4).

**Stats. Implemented:** ORS 654.001 through 654.295.

**Hist:** OR-OSHA Admin. Order 5-2003, f. 6/02/03, ef. 12/01/03.

# REPORTING FATALITIES & HOSPITALIZATIONS TO OREGON OSHA

# B

**\*\*\*IMPORTANT INFORMATION\*\*\*** A new reporting rule (OAR 437-001-0704 Reporting Fatalities and Injuries to Oregon OSHA) was adopted March 18, 2015, and **becomes effective January 1, 2016**. You can view this new rule on Oregon OSHA's web site [www.orosha.org](http://www.orosha.org) in Adopted Rules and Final Rules in Division 1, General Administrative Rules. OAR 437-001-0700(21) is still in effect through December 31, 2015.

**NOTE:** This rule printed here from Division 1, General Administrative Rules.

**437-001-0700(21) Reporting Fatalities and Hospitalizations to Oregon OSHA.** You must report the following to Oregon OSHA at 1-800-922-2689 or 503-378-3272 within the given time limits:

**(a) Fatalities** 8 hours after occurrence or employer knowledge

You must report a fatality caused by a heart attack at work. You must report a fatality resulting from motor vehicle accidents that happen during the employee's work shift. The local OR-OSHA field office safety or health manager will decide whether to investigate the incident, depending on the circumstances of the heart attack or motor vehicle accident. Report a fatality only if it occurs within 30 days of the accident.

**(b) Catastrophe** 8 hours after occurrence or employer knowledge.

For the ease of the reader the Definition for Catastrophe is – An accident in which two or more employees are fatally injured, or three or more employees are admitted to a hospital or an equivalent medical facility.

**(c) Overnight Hospitalization** 24 hours after occurrence or employer knowledge of one or more employees.

Overnight hospitalization is for medical treatment only. Hospitalization for observation is not reportable, nor is emergency room treatment. You must report injuries related to a heart attack or motor vehicle accident as well as other work related injuries.

Report overnight hospitalizations to the nearest Oregon OSHA field office (Portland, Salem, Bend, Eugene or Medford).

# B

## PRESERVING PHYSICAL EVIDENCE AT THE SCENE OF AN ACCIDENT

Oregon Administrative Rules  
Oregon Occupational Safety  
and Health Division

**NOTE:** Oregon OSHA Field Office locations, telephone and Fax numbers are:

Salem Central Office  
350 Winter Street NE, Room 430  
Salem OR 97301-3882  
(503) 378-3272  
Toll Free: (800) 922-2689  
Fax: (503) 947-7461

Eugene  
1140 Willagillespie, Suite 42  
Eugene OR 97401-2101  
(541) 686-7562  
Fax: (541) 686-7933

Medford  
1840 Barnett Road, Suite D  
Medford OR 97504-8250  
(541) 776-6030  
Fax: (541) 776-6246

Portland  
Fremont Place, Building I  
1750 NW Naito Parkway, Suite 112  
Portland OR 97209-2533  
(503) 229-5910  
Fax: (503) 229-6492

Bend  
Red Oaks Square  
1230 NE Third Street, Suite A-115  
Bend OR 97701-4374  
(541) 388-6066  
Fax: (541) 388-6203

Pendleton  
721 SE Third Street, Suite 306  
Pendleton OR 97801-3056  
(541) 276-9175  
Fax: (541) 276-6869

Salem  
1340 Tandem Avenue NE, Suite 160  
Salem OR 97309-0417  
(503) 378-3274  
Fax: (503) 378-4921

**(d) Effective date.** The effective date for reporting of a fatality resulting from motor vehicle accidents that happen during the employees work shift is January 1, 2007.

**NOTE:** This rule printed here from Division 1, General Administrative Rules.

### **437-001-0053 Preserving Physical Evidence at the Scene of an Accident.**

**(1)** Employers, their representatives, or others shall not disturb the scene of a fatality or catastrophe other than to conduct the rescue of injured persons or mitigate an imminent danger until authorized by the Administrator (or designee), or directed by a recognized law enforcement agency.

**(2)** In order to preserve physical evidence at the scene of a fatality or catastrophe, the Administrator is authorized to limit the number of employer representatives or employee representatives accompanying the compliance officer during the documentation of the scene. The employer representative and employee representative must be provided an opportunity to document the scene prior to disturbance or removal of physical evidence.

**(3)** If an employer, their representative or others disturb the scene of a fatality or catastrophe other than to conduct the rescue of injured person(s) or mitigate an imminent danger before authorized by the Administrator or directed by a recognized law enforcement agency, a minimum penalty of \$200 may be assessed.

**Stat. Auth.:** ORS 654.025(2) and 656.726(4).

**Stats. Implemented:** ORS 654.001 through 654.295.

**Hist:** OR-OSHA Admin. Order 7-1992, f. 7/31/92, ef. 10/1/92.  
OR-OSHA Admin. Order 7-1999, f. 7/15/99, ef. 7/15/99.

# PLANNING, FIRST AID AND WORK CONDITIONS

# C

## TABLE OF CONTENTS

<b>437-007-0200</b>	Site Planning and Implementation .....	C-1
<b>437-007-0205</b>	Hazard Identification .....	C-1
<b>437-007-0210</b>	Checking System .....	C-2
<b>437-007-0215</b>	Working Alone.....	C-3
<b>437-007-0220</b>	Medical Services and First Aid .....	C-4
<b>437-007-0225</b>	Working Near Unstable Objects and Danger Trees.....	C-7
<b>437-007-0230</b>	Power Lines Safeguards.....	C-8
<b>437-007-0235</b>	Weather Conditions .....	C-9
<b>437-007-0240</b>	Night Logging.....	C-9
<b>437-007-0245</b>	Field Sanitation For Reforestation Activities.....	C-9

**C**

Oregon Administrative Rules  
Oregon Occupational Safety  
and Health Division

# SITE PLANNING & IMPLEMENTATION / HAZARD IDENTIFICATION

# C

## **437-007-0200 Site Planning and Implementation.**

(1) Before the start of any forest activities of more than one day duration, the employer must:

- (a) Conduct an onsite safety survey.
- (b) Hold a pre-work safety meeting with employees to discuss:
  - (A) The emergency medical evacuation plan.
  - (B) Site conditions and known hazards.
- (c) Document the pre-work safety meeting.

**NOTE:** The pre-work safety meeting can be used to meet the monthly safety meeting requirement 437-007-0130(4).

(2) Before work starts, a competent person must evaluate any danger tree(s) or snag(s) within reach of a work area to determine if it poses a hazard to personnel. If the tree(s) or snag(s) poses a hazard, it must be felled or the work arranged to minimize danger to workers.

(3) Workers must be placed and their activities arranged so they are in the clear and the actions of one worker will not create a hazard for any other worker(s).

**Stat. Auth.:** ORS 654.025(2) and 656.726(4).  
**Stats. Implemented:** ORS 654.001 through 654.295.  
**Hist:** OR-OSHA Admin. Order 5-2003, f. 6/02/03, ef. 12/01/03.

## **437-007-0205 Hazard Identification.**

(1) The employer must ensure that identified hazards are marked with hazard identification ribbon. The hazard identification ribbon must be bright orange, at least 1 1/2 inches wide, and marked in black with "skull and crossbones" and/or the word "Danger."

(2) The employer must notify employees of existing marked hazards in their work area.

(3) The employer must instruct all employees in the recognition and use of hazard identification ribbon.

(4) Hazard Identification ribbon must be available for employee use and carried by all cutters.

**C****HAZARD IDENTIFICATION /  
CHECKING SYSTEMS**Oregon Administrative Rules  
Oregon Occupational Safety  
and Health Division

**(5)** Hazard identification ribbon must not be used for any other purpose than identifying hazards and must be removed when the hazard is abated.

**Stat. Auth.:** ORS 654.025(2) and 656.726(4).

**Stats. Implemented:** ORS 654.001 through 654.295.

**Hist:** OR-OSHA Admin. Order 5-2003, f. 6/02/03, ef. 12/01/03.

**437-007-0210 Checking System.**

**(1)** The employer must implement a checking system to account for all employees at the end of each work shift. Employees must be knowledgeable about the checking system.

**(2)** The employer must implement a system to check the well-being of those workers whose jobs may be single employee assignments, as provided for in OAR 437-007-0215(3). The system must include:

**(a)** The time interval between checks and the procedures to be followed if the employee cannot be contacted, including provisions for emergency medical care and treatment.

**(b)** A specific person must be assigned for:

**(A)** Contacting the lone employee.

**(B)** Verifying when contacts were made.

**(c)** The time intervals for checking the single employee's well-being must be understood and agreed to by all parties. Intervals should reflect the hazardous nature of the work and the methods available for checking.

**(d)** The system for checking an employee's well-being must be reviewed at least annually, or more frequently if there is a change in work arrangements/assignments which could adversely affect an employee's well-being, or a report that the system is not working effectively.

**Stat. Auth.:** ORS 654.025(2) and 656.726(4).

**Stats. Implemented:** ORS 654.001 through 654.295.

**Hist:** OR-OSHA Admin. Order 5-2003, f. 6/02/03, ef. 12/01/03.

## **437-007-0215 Working Alone.**

**(1)** The employer must not assign workers to a task or location so isolated as to be without visual, audible, or radio contact with another person who can summon or provide aid in an emergency.

**(2)** Unless otherwise specified in these rules, in any operation where fire, suppression, prescribed fire, tree climbing, power chain saw operation, yarding, loading or a combination of these duties is carried on, there must be a minimum crew of two employees who must work as a team and must be in visual or natural unassisted voice communication with one another.

**(3)** Workers are not prohibited from working alone when performing certain jobs which by their nature may be single employee assignments, such as: mechanics, watchers, the operation of motor vehicles, self-loading log trucks, mechanized logging machines, feller bunchers, forwarders, processors, harvesters or excavator-based machines, provided the employer complies with the requirements of 437-007-0210(2), Checking System; 437-007-0775, Protective Structures for Operators; and 437-007-0220, Medical Services and First Aid.

**(4)** Mechanics or other employees must not be assigned to work on machines by themselves when there is a probability of a fall from elevated work locations or machines. When the work is of such nature that heavy parts require moving, or there is a probability that anything heavy could fall on the person, there must be another person in the area who can render immediate assistance or emergency care.

**Stat. Auth.:** ORS 654.025(2) and 656.726(4).

**Stats. Implemented:** ORS 654.001 through 654.295.

**Hist:** OR-OSHA Admin. Order 5-2003, f. 6/02/03, ef. 12/01/03.  
OR-OSHA Admin. Order 2-2005, f. 5/27/05, ef. 6/1/05.

**C****MEDICAL SERVICES &  
FIRST AID**Oregon Administrative Rules  
Oregon Occupational Safety  
and Health Division**437-007-0220 Medical Services and First Aid.**

- (1) The employer must develop and implement an emergency medical plan to ensure emergency medical service to employees with major illnesses and injuries.
- (2) All employees must be knowledgeable concerning the emergency care and emergency medical treatment plan.
- (3) All personnel employed in forest activities must be trained in first aid and CPR as follows:
  - (a) In a language they understand.
  - (b) At least every 2 years or as required by a nationally recognized first aid training provider.
  - (c) All supervisors and all cutters must be first aid and CPR trained prior to their initial assignment.
  - (d) All new employees, other than supervisors and cutters, that are not first aid and CPR trained prior to their initial assignment must receive a first aid and CPR briefing.
  - (e) All new employees must receive first aid and CPR training within 6 months of being hired.
  - (f) For the initial start-up of a side or operation where new employees are assigned, at least one out of every five crew members must be first aid and CPR trained before work starts.

**NOTE 1:** Log truck drivers and watchers are not required to receive first aid and CPR training if they are not involved with falling, yarding or processing logs.

**NOTE 2:** See the Oregon OSHA Division 2, Subdivision 2/Z, Toxic and Hazardous Substances, §1910.1030, Bloodborne Pathogens, if an employee comes into contact with blood or other potentially infectious material as the result of providing first aid.

- (4) Each worksite must have at least one serviceable and operable two-way radio, phone or radio/phone combination available to reach ambulance service. Citizens' band radios are permitted only as a secondary means of communication.

**NOTE:** This rule does not apply to road graders, log and dump trucks, crew buses and similar mobile equipment that service locations where a communication unit is already available (e.g., yarders, loaders).

- (5) Each operating site or crew in a communication “dead” area must have a mobile communication unit or advance plans to relay emergency calls through another site operating in the vicinity.

# MEDICAL SERVICES & FIRST AID

C

**(6)** At worksites of more than one day duration, the employer must have available near the worksite communication device(s):

- (a)** Written land directions to the worksite.
- (b)** The worksite location by Township, Range and Section.

**(7)** When air evacuation is available to any worksite of more than one day duration, the employer must have available, near the worksite communication device(s), the:

- (a)** Name and phone number of the air evacuation service.
- (b)** Worksite location by latitude and longitude or township, range and section as required by the air service.

**(8)** The employer must assure that transportation is always available to:

- (a)** A point where an ambulance can be met, or
- (b)** The nearest suitable medical facility.

**(9)** Vehicles used for the transportation of personnel must carry a first aid kit:

- (a)** Suitable for the number of passengers customarily transported.
- (b)** Suitable for the types of injuries that could occur.
- (c)** Located where they are readily available to the driver or crew.

**(10)** First aid kits must be provided at each worksite.

**(11)** Worksite first aid kits must contain the following minimum supplies at all times:

- (a)** Eight gauze pads individually wrapped (at least 4 inches by 4 inches in size);
- (b)** Two large gauze pads that are or can be folded to an approximate size of 8 inches by 10 inches or the equivalent;
- (c)** One box adhesive bandages;
- (d)** One package gauze roller bandage at least 2 inches wide or the equivalent;
- (e)** Two triangular bandages;
- (f)** Wound-cleaning agent, such as sealed, moistened towelettes, or soap and water;

**C****MEDICAL SERVICES &  
FIRST AID**Oregon Administrative Rules  
Oregon Occupational Safety  
and Health Division

- (g)** Scissors;
- (h)** One stretcher or equivalent weatherproof litter at any three or more person worksite, and at all logging sites;
- (i)** Two blankets, one of which must provide the strength and insulation equivalent to a wool blanket;
- (j)** Latex gloves;
- (k)** Mouth barrier;
- (l)** Tweezers;
- (m)** Adhesive tape;
- (n)** Two elastic wraps; and
- (o)** Splint material.

**NOTE:** The quantities of each item are minimum amounts. Bulk pack or unit pack supplies are acceptable. First aid supplies from other states may be acceptable if such supplies are the reasonable equivalent of those required by this rule.

- (12)** The employer also may have the number and content of first aid kits reviewed and approved annually by a health care provider.
- (13)** First aid supplies must be regularly inspected and replenished as needed.
- (14)** First aid supplies must be stored in containers adequate to protect the contents from damage, deterioration or contamination.
  - (a)** The containers must be clearly marked "First Aid."
  - (b)** The container must not be locked, but may be sealed.
  - (c)** Soap and water, stretcher, or basket and blankets may be stored separately, but must be near or with the first aid supplies.
- (15)** All employees must be informed of the location of first aid supplies.

**Stat. Auth.:** ORS 654.025(2) and 656.726(4).

**Stats. Implemented:** ORS 654.001 through 654.295.

**Hist:** OR-OSHA Admin. Order 5-2003, f. 6/02/03, ef. 12/01/03.  
OR-OSHA Admin. Order 3-2004, f. 6/7/04, ef. 6/7/04.

# WORKING NEAR UNSTABLE OBJECTS & DANGER TREES

# C

## 437-007-0225 Working Near Unstable Objects and Danger Trees.

(1) Each day in the course of forest activities, a general inspection must be conducted of the areas to be worked that day to identify trees, logs, rootwads, rocks, chunks or other objects that may roll, slide or fall towards personnel. If any object is likely to move during work activity, it must be removed, stabilized, or the work activities modified so that the unstable objects are no longer a hazard.

**NOTE:** Consideration must be given to rain, snow, other weather conditions, or working below felled and bucked timber that may increase the likelihood that objects may roll, slide or fall.

(2) On a daily basis, a competent person must evaluate any danger tree(s) or snag(s) within reach of a work area to determine if it poses a hazard to personnel. If the tree(s) or snag(s) poses a hazard it must be fell or the work arranged to minimize danger to workers.

(3) Personnel must be alert at all time for logs, trees, rootwads, rocks or other objects that could roll or slide towards them or others as a result of any work activity.

(4) Trees must not be fell or bucked within a unit of standing timber prior to any cutting operation if such falling or bucking creates a hazardous condition for subsequent cutters or cutting operations.

(5) During road building and maintenance operations, right-of-way log decks, rootwads, slash and rocks must be placed on stable locations so that personnel are not exposed to the hazards of working near unstable objects.

**Stat. Auth.:** ORS 654.025(2) and 656.726(4).

**Stats. Implemented:** ORS 654.001 through 654.295.

**Hist:** OR-OSHA Admin. Order 5-2003, f. 6/02/03, ef. 12/01/03.

**437-007-0230 Power Line Safeguards.**

(1) Forest activities operations near overhead electric lines must be done in accordance with the requirements of OAR 437, Division 2/S, Electrical, §1910.333(c)(3), Selection and Use of Work Practices.

(2) When any machinery is being moved or operated in the vicinity of an overhead power line, a minimum clearance of 15 feet must be maintained between the overhead power lines and all elements of the machine, including logs, trees, or other material being handled by the machine.

**NOTE:** Any overhead power line must be considered to be an energized line until the person owning the line or the electrical utility authorities indicate that it is not energized.

(3) While falling trees, the minimum distance required by this section applies when a tree could fall within 15 feet of an overhead power line.

(4) The minimum distance required when cable yarding must not be reduced by line whip or breakage.

(5) A person must be designated to observe clearance and give timely warning for all operations where it is difficult for the operator to maintain the required distance by visual means.

(6) If work activities could encroach upon the minimum clearance required by this section, the employer or person responsible for the work to be done must promptly notify the power company in accordance with ORS 757.805, Oregon's Overhead Line Safety Act. The responsible party and the power company must complete mutually satisfactory safety measures as required before proceeding with any work which would impair the aforesaid clearance.

(7) If contact is made with a power line by a tree, rigging, machinery, or the structure supporting the overhead powerline is damaged by forest activities, the power company must be notified immediately and all employees must remain clear of the area until power company personnel advise that conditions are safe.

**Stat. Auth.:** ORS 654.025(2) and 656.726(4).

**Stats. Implemented:** ORS 654.001 through 654.295.

**Hist:** OR-OSHA Admin. Order 5-2003, f. 6/02/03, ef. 12/01/03.  
OR-OSHA Admin. Order 2-2005, f. 5/27/05, ef. 6/1/05.

# WORKING CONDITIONS / NIGHT LOGGING / FIELD SANITATION FOR REFORESTATION ACTIVITIES

# C

**437-007-0235 Working Conditions.** A competent person must determine if work activities can be safely conducted during inclement weather conditions or darkness. When weather conditions or darkness pose a hazard to workers, the activity must be discontinued until the work is arranged to mitigate the hazard.

**NOTE:** This rule does not prohibit logging or wildland fire suppression activities at night, but it requires an assessment of conditions so work can be done safely.

**Stat. Auth.:** ORS 654.025(2) and 656.726(4).

**Stats. Implemented:** ORS 654.001 through 654.295.

**Hist:** OR-OSHA Admin. Order 5-2003, f. 6/02/03, ef. 12/01/03.  
OR-OSHA Admin. Order 2-2005, f. 5/27/05, ef. 6/1/05.

## 437-007-0240 Night Logging.

(1) Where work is conducted during the hours of darkness, the work area must be provided with illumination which will allow employees to safely perform their duties. The sources of illumination must be located and directed so as to create a minimum of shadows and glare.

(2) Where it is not practical to provide illumination for the work area, other means, such as local sources of illumination or headlamps, must be used by all personnel.

(3) If using a portable tailhold, lights must be directed on the equipment to permit the employee to visually ascertain that the tailhold equipment remains stabilized.

(4) Personnel working at night must wear reflective stripes at least 1-inch wide visible from all directions on upper body cover or hard hats.

**Stat. Auth.:** ORS 654.025(2) and 656.726(4).

**Stats. Implemented:** ORS 654.001 through 654.295.

**Hist:** OR-OSHA Admin. Order 5-2003, f. 6/02/03, ef. 12/01/03.

## 437-007-0245 Field Sanitation For Reforestation Activities.

(1) Toilet and hand washing facilities must be provided by the employer when it is feasible for employees to use them.

(2) Where it is not feasible to use toilet and hand washing facilities, the employer must provide, at no cost to employees, suitable substitutes such as sanitary kits.

**NOTE:** Sanitary kits would include moist towelettes and hand towels for hand washing.

(3) The employer must provide, at no cost to employees, potable water and the means to carry it.

**Stat. Auth.:** ORS 654.025(2) and 656.726(4).

**Stats. Implemented:** ORS 654.001 through 654.295.

**Hist:** OR-OSHA Admin. Order 5-2003, f. 6/02/03, ef. 12/01/03.

**C**

Oregon Administrative Rules  
Oregon Occupational Safety  
and Health Division

# PERSONAL PROTECTIVE EQUIPMENT & PROGRAMS

# D

## TABLE OF CONTENTS

<b>437-007-0300</b>	General Requirements .....	D-1
<b>437-007-0305</b>	Head Protection.....	D-1
<b>437-007-0310</b>	High-Visibility Color .....	D-2
<b>437-007-0315</b>	Eye and Face Protection .....	D-2
<b>437-007-0320</b>	Hand Protection.....	D-2
<b>437-007-0325</b>	Leg Protection .....	D-2
<b>437-007-0330</b>	Foot Protection .....	D-3
<b>437-007-0335</b>	Hearing Protection.....	D-3
<b>437-007-0340</b>	Personal Flootation Devices .....	D-4
<b>437-007-0345</b>	Respiratory Protection .....	D-4
<b>437-007-0350</b>	Respiratory Protection When Machines are Operated .....	D-5

**D**

Oregon Administrative Rules  
Oregon Occupational Safety  
and Health Division

# GENERAL REQUIREMENTS / HEAD PROTECTION

# D

## 437-007-0300 General Requirements.

- (1) Personal protective equipment, including any personal protective equipment provided by an employee, must be maintained in a safe and effective condition, or removed from service or use.
- (2) Personal protective equipment must be inspected before initial use during each workshift.
- (3) Defective or damaged personal protective equipment must be repaired or replaced before it is put into service.
- (4) When the employer is required to provide personal protective equipment, it must be at no cost to the employee, unless a specific exception is noted.

**Stat. Auth.:** ORS 654.025(2) and 656.726(4).

**Stats. Implemented:** ORS 654.001 through 654.295.

**Hist:** OR-OSHA Admin. Order 5-2003, f. 6/02/03, ef. 12/01/03.

## 437-007-0305 Head Protection.

(1) Where there is potential for head injury from falling or flying objects, the employer must provide and require the use of head protection (hard hats) that comply with any of the following consensus standards.

- (a) ANSI Z89.1-2003, "American National Standard for Industrial Head Protection;"
- (b) ANSI Z89.1-1997, "American National Standard for Industrial Head Protection;" or
- (c) ANSI Z89.1-1986, "American National Standard for Personnel Protection – Protective Headwear for Industrial Workers – Requirements."

**NOTE:** The Oregon OSHA Resource Center has copies for public review at 350 Winter Street NE, Salem OR 97309-0405.

**EXCEPTION:** Employees working in or under a vehicle cab or canopy are excluded from wearing a hard hat while in, or under, a vehicle.

(2) The employer must replace, at no cost to the employee, head protection (hard hat) that is no longer serviceable because of reasonable wear and tear.

**Stat. Auth.:** ORS 654.025(2) and 656.726(4).

**Stats. Implemented:** ORS 654.001 through 654.295.

**Hist:** OR-OSHA Admin. Order 5-2003, f. 6/02/03, ef. 12/01/03.

OR-OSHA Admin. Order 2-2010, f. 2/25/10, ef. 2/25/10.

# D

## HIGH-VISIBILITY COLOR / EYE & FACE / HAND / LEG PROTECTION

Oregon Administrative Rules  
Oregon Occupational Safety  
and Health Division

**437-007-0310 High-Visibility Color.** All employees exposed to the potential hazard of moving lines, falling timber, logs, vehicles, machines and other moving equipment or materials must wear upper body cover and/or hard hats of a high-visibility color, that contrasts with the background color(s).

**Stat. Auth.:** ORS 654.025(2) and 656.726(4).  
**Stats. Implemented:** ORS 654.001 through 654.295.  
**Hist:** OR-OSHA Admin. Order 5-2003, f. 6/02/03, ef. 12/01/03.

**437-007-0315 Eye and Face Protection.** Where chips, sawdust or flying particles present a hazard, the employer must provide and require personnel to wear eye and face protection meeting the requirement of Division 2/l.

**NOTE:** Logger-type mesh screen may be used for chain saw operators.

**Stat. Auth.:** ORS 654.025(2) and 656.726(4).  
**Stats. Implemented:** ORS 654.001 through 654.295.  
**Hist:** OR-OSHA Admin. Order 5-2003, f. 6/02/03, ef. 12/01/03.

**437-007-0320 Hand Protection.** The employer must provide and require employees to use hand protection:

- (1) Such as cotton gloves or other suitable hand protection whenever employees handle lines, rough material or when the nature of the work requires protection for the hands.
- (2) When the employees' hands are exposed to hazards such as those from skin absorption of harmful substances, chemical and thermal burns.

**Stat. Auth.:** ORS 654.025(2) and 656.726(4).  
**Stats. Implemented:** ORS 654.001 through 654.295.  
**Hist:** OR-OSHA Admin. Order 5-2003, f. 6/02/03, ef. 12/01/03.

**437-007-0325 Leg Protection.** The employer must provide and require each employee who operates a chain saw to wear flexible ballistic nylon pads, chaps or other equivalent protection in a manner that protects their legs from the top of the thigh to the top of the boot from contact with the moving saw chain.

**EXCEPTION:** This does not apply to an employee working aloft in trees when supported by climbing spurs and climbing belt.

**Stat. Auth.:** ORS 654.025(2) and 656.726(4).  
**Stats. Implemented:** ORS 654.001 through 654.295.  
**Hist:** OR-OSHA Admin. Order 5-2003, f. 6/02/03, ef. 12/01/03.

# FOOT PROTECTION / HEARING PROTECTION

# D

## 437-007-0330 Foot Protection.

(1) All personnel must wear foot protection, such as heavy-duty boots, that:

- (a) Are waterproof or water-repellant where wet conditions exist.
- (b) Cover and support the ankle.

**NOTE:** The employer is not required to provide logging boots for employees. The cost of logging boots may be borne by employees. The employer must assure, however, that logging boots, as well as all PPE provided by the employer, are worn by employees and are in serviceable condition and meet the requirements of Subdivision 7/D.

(2) Personnel who operate chain saws must wear cut resistant foot protection that will protect against contact with running saw chains.

(3) Personnel whose duties require them to walk on trees, logs or boomsticks, must wear sharp caulked boots, or the equivalent.

(4) When conditions such as ice, snow, mud, rocky terrain, etc., render caulks ineffective, heavy duty slip-resistant type work boots that provide ankle support must be worn.

(5) When nonslip-type shoes or boots afford a greater degree of employee protection than caulk shoes, such as at scaling stations, log sorting yards, etc., then this type footwear may be worn in lieu of caulk shoes providing firm ankle support and secure footing are maintained.

**Stat. Auth.:** ORS 654.025(2) and 656.726(4).

**Stats. Implemented:** ORS 654.001 through 654.295.

**Hist:** OR-OSHA Admin. Order 5-2003, f. 6/02/03, ef. 12/01/03.

## 437-007-0335 Hearing Protection.

(1) Personnel must be protected from the effects of noise exposures in accordance with OAR Chapter 437, Division 2/G, Occupational Health and Environmental Control.

(2) Personnel must wear hearing protection unless monitored under typical work conditions and found to be exposed to a noise level of less than an 8-hour time-weighted average (TWA) of 85 db when:

- (a) Operating chain saws, other noise producing equipment, or machines.
- (b) Working on landings.

**Stat. Auth.:** ORS 654.025(2) and 656.726(4).

**Stats. Implemented:** ORS 654.001 through 654.295.

**Hist:** OR-OSHA Admin. Order 5-2003, f. 6/02/03, ef. 12/01/03.

**D****PERSONAL FLOTATION DEVICES /  
RESPIRATORY PROTECTION**Oregon Administrative Rules  
Oregon Occupational Safety  
and Health Division

**437-007-0340 Personal Floatation Devices.** When working on or over water, personnel must be provided with and must wear approved buoyant protective equipment as required by Division 2/I, OAR 437-002-0139.

**Stat. Auth.:** ORS 654.025(2) and 656.726(4).

**Stats. Implemented:** ORS 654.001 through 654.295.

**Hist:** OR-OSHA Admin. Order 5-2003, f. 6/02/03, ef. 12/01/03.

**437-007-0345 Respiratory Protection.**

**(1)** When employees are exposed to air contaminants that exceed applicable permissible exposure limits (PEL) as required by Division 2/Z, OAR 437-002-0382, Oregon Rules for Air Contaminants, the employer must provide and enforce the use of respiratory protective equipment as required in Division 2/I, §1910.134.

**(2)** Employees must be provided protection from dust when exposed to total dust levels of 10 milligrams per cubic meter of air per 8-hour time-weighted average (TWA).

**(3)** If respirators are used for protection from dust, created by the operation of machines, the employer must follow the requirements of Division 2/I, §1910.134, or the requirements of 437-007-0350.

**Stat. Auth.:** ORS 654.025(2) and 656.726(4).

**Stats. Implemented:** ORS 654.001 through 654.295.

**Hist:** OR-OSHA Admin. Order 5-2003, f. 6/02/03, ef. 12/01/03.

# RESPIRATORY PROTECTION WHEN MACHINES ARE OPERATED

# D

## **437-007-0350 Respiratory Protection When Machines Are Operated.**

**(1)** When the operation of machines expose any employee to dusty conditions and an air-purifying respirator or filtering facepiece is used for personal protection, the respirator must have a N-95 filter rating unless employees are monitored under typical work conditions and found to be exposed to total dust levels less than 10 milligrams per cubic meter of air per 8-hour time-weighted average (TWA).

**(2)** When the use of a respirator is required by the standard, the employer must provide respirators, medical evaluations and training, at no cost to the employee.

**(3)** Before any employee is permitted to use an air-purifying respirator, they must complete a medical evaluation performed by a physician or other licensed health care professional.

**NOTE 1:** This evaluation can be performed by using:

- (a)** A medical questionnaire, or
- (b)** An initial medical examination that obtains the same information as the medical questionnaire.
- (c)** A medical evaluation is not required if the employee is voluntarily using an approved respirator.

**NOTE 2:** Use Appendix 7-G, Respiratory Medical Evaluation Questionnaire (Mandatory).

**(4)** The employer must train employees:

- (a)** About the respiratory hazards to which they are potentially exposed during routine work.
- (b)** In the proper use of respirators, including putting on and removing them, any limitations on their use, maintenance and storage.

**(5)** Respirators must be clean and maintained in good working order.

**(6)** Respirators must be stored in a dry and sanitary place.

**(7)** Respiratory protection must be:

- (a)** NIOSH-certified.
- (b)** Used in compliance with the conditions of its certification.

# D

## RESPIRATORY PROTECTION WHEN MACHINES ARE OPERATED

Oregon Administrative Rules  
Oregon Occupational Safety  
and Health Division

(8) When wearing air purifying respirators for personal protection:

- (a) Facial hair must not come between the sealing surface on the facepiece and the face.
- (b) Facial hair must not interfere with valve function.
- (c) Conditions must not interfere with the face-to-facepiece seal or valve function (facial characteristic, glasses, etc.).

(9) A qualitative fit test (QLFT) must be performed before employees use a tight fitting air purifying respirator.

**NOTE:** This is a pass/fail fit test to assess the adequacy of respirator fit that relies on the individual's response to the test agent.

(10) Employees using a tight fitting air-purifying respirator must perform a user seal check to ensure that an adequate seal is achieved each time the respirator is put on.

(11) Employees must use either the positive and negative pressure check method, or follow the respirator manufacturer's recommended user seal check method.

(12) Positive pressure checks must be performed by closing off the exhalation valve and exhale gently into the facepiece.

**NOTE 1:** The face fit is considered to be satisfactory if a slight positive pressure can be built up inside the facepiece without any evidence of outward leakage of air at the seal.

**NOTE 2:** For most respirators this method of leak testing requires the wearer to first remove the exhalation valve cover before closing off the exhalation valve and then carefully replacing it after the test.

(13) Negative pressure checks must be performed by closing off the inlet opening of the canister or cartridge(s) by covering with the palm of the hand(s) or by replacing the filter seal(s), and then inhaling gently so that the facepiece collapses slightly.

**NOTE 1:** If the facepiece remains in its slightly collapsed condition and no inward leakage of air is detected, the tightness of the respirator is considered satisfactory.

**NOTE 2:** The design of the inlet opening of some cartridges cannot be effectively covered with the palm of the hand. The test can be performed by covering the inlet opening of the cartridge with a thin latex or nitrile glove.

**Stat. Auth.:** ORS 654.025(2) and 656.726(4).

**Stats. Implemented:** ORS 654.001 through 654.295.

**Hist:** OR-OSHA Admin. Order 5-2003, f. 6/02/03, ef. 12/01/03.

# TOOLS, FIRE EXTINGUISHERS AND EXPLOSIVES

# E

## TABLE OF CONTENTS

<b>437-007-0400</b>	Hand and Portable Power-Driven Tools .....	E-1
<b>437-007-0405</b>	Chain Saws .....	E-2
<b>437-007-0410</b>	Fire Extinguishers.....	E-4
<b>437-007-0415</b>	Explosives and Blasting Agents .....	E-5

<b>E</b>		Oregon Administrative Rules Oregon Occupational Safety and Health Division
----------	--	--

# HAND AND PORTABLE POWER-DRIVEN TOOLS

# E

## **437-007-0400 Hand and Portable Power-Driven Tools.**

- (1)** The employer is responsible for the safe condition of hand and portable power tools used in forest activities regardless of tool ownership.
- (2)** All safety devices and controls must be in place and function properly.
- (3)** The employer must require personnel to:
  - (a)** Inspect each tool before use to assure its safe condition.
  - (b)** Report any unsafe tool condition to the employer.
  - (c)** Remove or repair tools if the condition affects the safe operation.
- (4)** If a slick or slippery axe or hammer handle cannot be firmly gripped, the tool must not be used.
- (5)** Tools must be:
  - (a)** Appropriate for their use.
  - (b)** Used in a safe manner.
- (6)** Wooden handles must be sound, straight-grained and tight-fitting.
- (7)** Heads of shock or impact-driven and driving tools must be dressed or ground to remove any mushrooming.
- (8)** When the heads of shock or impact-driven tools show a tendency to chip, they must be removed from service.
- (9)** Cutting edges of tools must be sharp and properly shaped.
- (10)** When tools are not being used, they must be stored in a location where they will not create a hazard.
- (11)** Racks, boxes, holsters, barriers or equivalent means must be provided and used so the passengers and/or driver will not be endangered by tools, equipment or materials being transported, loaded or removed.

**Stat. Auth.:** ORS 654.025(2) and 656.726(4).

**Stats. Implemented:** ORS 654.001 through 654.295.

**Hist:** OR-OSHA Admin. Order 5-2003, f. 6/02/03, ef. 12/01/03.

**437-007-0405 Chain Saws.**

- (1) Chain saws must be inspected before use.
  - (2) Chain saws must not be used if they have cracked or loose handle bars or defective vital parts.
  - (3) Chain saws must be operated and adjusted in accordance with the manufacturer's instructions.
  - (4) Chain saws must not be fueled with the engine running.
  - (5) Chain saws must be fueled at least 10 feet (3 m) from open flames or other source of ignition.
  - (6) Chain saws must not be started within 10 feet (3 m) of the fueling area.
  - (7) Chain saws must have an operable chain brake, if originally designed and equipped with a chain brake.
  - (8) Chain brakes and other manufacturer's safety features must be operational at all times.
  - (9) Chain saws must be equipped with an automatic throttle control which will return the engine to idling speed upon release of the throttle.
- NOTE:** "Idling" is when the chain is not moving while the engine is running.
- (10) Each chain saw must meet all applicable requirements of American National Standard, ANSI B175.1-1991, Safety Requirements for Gasoline-Powered Chain Saws, except where exempt by these rules.
  - (11) Chain saws must be started on the ground if they are not otherwise firmly supported.
- NOTE:** This does not apply to personnel working aloft in trees when supported by climbing spurs and climbing belt.
- (12) Chain brakes must be engaged when feasible, while chain saws are being started, unless the manufacturer recommends otherwise.
  - (13) Chain saw operators must be certain of footing before starting to cut.
  - (14) Chain saws must be held with the thumbs and fingers of both hands encircling the handles during operation unless the employer demonstrates that a greater hazard is posed by keeping both hands on the chain saw in that particular situation.

**(15)** Personnel must not use a chain saw:

**(a)** To cut directly overhead in a manner that would cause limbs, chunks of bark or pieces of wood to fall on the operator.

**(b)** At a distance that would require them to relinquish a safe grip on the saw.

**(c)** In a position or at a distance that could cause them to:

**(A)** Become off balance, or

**(B)** Have insecure footing.

**(16)** Chain saws must be carried in a manner that will not create a hazard for the operator.

**(17)** Where terrain or brush creates a hazardous condition, the chain saw engine must be shut off while the operator is walking.

**(18)** The chain saw must be shut down or the chain brake must be engaged whenever a saw is carried farther than 50 feet.

**Stat. Auth.:** ORS 654.025(2) and 656.726(4).

**Stats. Implemented:** ORS 654.001 through 654.295.

**Hist:** OR-OSHA Admin. Order 5-2003, f. 6/02/03, ef. 12/01/03.

**437-007-0410 Fire Extinguishers.**

(1) Portable fire extinguisher use, training and maintenance must be in accordance with OAR Chapter 437, Division 2, Subdivision L, Fire Protection.

(2) Fire extinguishers or protection systems must be of a type approved by a nationally recognized testing laboratory (NRTL) (see OAR 437, Division 2/A, §1910.7, for definition of NRTL).

(3) There must be an approved fire extinguisher with a minimum rating of 1A:10BC (or equivalent) on each vehicle and machine, or the area where the vehicles and machines are operated.

(4) After July 1, 2007, fire extinguishers provided on each vehicle and machine must be 2A:10BC or provide equivalent protection.

(5) Fire extinguishers must be fully charged and maintained in operable condition.

(6) Portable extinguishers must be visually inspected monthly.

(7) Portable extinguishers must have an annual maintenance check.

**NOTE:** Stored pressure extinguishers do not require an internal examination.

(8) The annual maintenance check date must be recorded and this record must be retained for one year.

(9) Each motor vehicle used for transporting explosive materials must be equipped with fire extinguishers as follows:

(a) Vehicle less than 14,000 pounds must have at least two extinguishers having a combined capacity of 4A:20BC.

(b) Vehicle 14,000 pounds or greater and tractor/semi-trailer units must have at least two extinguishers having a combined capacity of 4A:70BC.

**Stat. Auth.:** ORS 654.025(2) and 656.726(4).

**Stats. Implemented:** ORS 654.001 through 654.295.

**Hist:** OR-OSHA Admin. Order 5-2003, f. 6/02/03, ef. 12/01/03.

# EXPLOSIVES & BLASTING AGENTS

# E

## **437-007-0415 Explosives and Blasting Agents.**

(1) The storage, transportation, handling, and use of explosives and blasting agents must be in accordance with OAR Chapter 437, Division 3, Subdivision U, Blasting and The Use of Explosives.

(2) Explosives and blasting agents must be handled only by qualified, designated personnel.

(3) Explosives and blasting agents must not be transported in:

(a) The driver's compartment.

(b) Any passenger-occupied area of a machine or vehicle.

(4) Explosives must not be hauled on any vehicle while it is engaged in transporting workers.

**EXCEPTION:** This rule does not prohibit the driver and one qualified person from riding in a vehicle in which explosives are being hauled.

**Stat. Auth.:** ORS 654.025(2) and 656.726(4).

**Stats. Implemented:** ORS 654.001 through 654.295.

**Hist:** OR-OSHA Admin. Order 5-2003, f. 6/02/03, ef. 12/01/03.

<b>E</b>		Oregon Administrative Rules Oregon Occupational Safety and Health Division
----------	--	--

# ROADS, FLAGGING, VEHICLES AND FLAMMABLES

# F

## TABLE OF CONTENTS

<b>437-007-0500</b>	Roads .....	F-1
<b>437-007-0505</b>	Bridges.....	F-2
<b>437-007-0510</b>	Flagging.....	F-2
<b>437-007-0515</b>	Signs.....	F-3
<b>437-007-0520</b>	Vehicle General Requirements .....	F-5
<b>437-007-0525</b>	Vehicle Warning Devices .....	F-5
<b>437-007-0530</b>	Vehicle Windshields, Windows and Mirrors.....	F-5
<b>437-007-0535</b>	Vehicle Passenger Compartments .....	F-6
<b>437-007-0540</b>	Vehicle Brakes.....	F-6
<b>437-007-0545</b>	Vehicle Exhaust Systems .....	F-7
<b>437-007-0550</b>	Vehicle Guards and Controls .....	F-7
<b>437-007-0555</b>	Vehicle Safety Chains .....	F-8
<b>437-007-0560</b>	Vehicle Seat Belts .....	F-8
<b>437-007-0565</b>	Vehicle Inspection, Maintenance and Repair .....	F-9
<b>437-007-0570</b>	Vehicle Operation .....	F-9
<b>437-007-0575</b>	Transportation of Personnel.....	F-10
<b>437-007-0580</b>	Flammable and Combustible Liquids .....	F-10

**F**

Oregon Administrative Rules  
Oregon Occupational Safety  
and Health Division

## **437-007-0500 Roads.**

- (1)** Haul roads must be of sufficient width and evenness for safe operation of vehicles and machines.
- (2)** Haul roads and bridges must be constructed and maintained to accommodate the safe movement of vehicles and machines.
- (3)** Vehicles and machines must not be moved on any access roadway or grade that will not accommodate the safe movement of vehicles and machines.
- (4)** When haul road grades exceed 20 percent slope:
  - (a)** The vehicle or machine must be approved by the manufacturer for operation on the steeper grades.
  - (b)** Additional precautions must be taken, such as assisting or snubbing the vehicle or machine down the slope.
- (5)** Deep holes, large rocks, logs, or other dangerous surface defects on roads must be corrected before starting logging operations.
- (6)** On those portions of roads under the direct control of the employer:
  - (a)** All danger trees that can fall or slide onto roadways must be felled.
  - (b)** Loose rocks, stumps and other materials which present a hazard must be secured or cleared from banks.
- (7)** Root wads, logs, and other unstable debris must not be placed against standing timber in a manner that creates a hazard for timber falling, logging operations or other forest activities.

**Stat. Auth.:** ORS 654.025(2) and 656.726(4).

**Stats. Implemented:** ORS 654.001 through 654.295.

**Hist:** OR-OSHA Admin. Order 5-2003, f. 6/02/03, ef. 12/01/03.

**437-007-0505 Bridges.**

- (1) All bridge structures and surfaces must be:
- (a) Adequate to support the maximum imposed loads.
  - (b) Maintained in good repair.
- (2) All bridges must have rub rails constructed of wood, concrete or equivalent materials that:
- (a) Have a minimum height of 9 inches (6-inch by 6-inch timbers set on 4-inch by 6-inch blocks).
  - (b) Are secured to the bridge deck.

**Stat. Auth.:** ORS 654.025(2) and 656.726(4).

**Stats. Implemented:** ORS 654.001 through 654.295.

**Hist:** OR-OSHA Admin. Order 5-2003, f. 6/02/03, ef. 12/01/03.

**437-007-0510 Flagging.**

- (1) Warning signs and a flagger(s) must be placed in advance of active operations, or other equivalent protection must be used on roads to control traffic where hazardous conditions are created from forest activities, such as, but not limited to:
- (a) Skylines and running lines or rigging across road grades, excluding tightened guylines.
  - (b) The movement of logs, chunks or debris across or suspended over road grades.
  - (c) Timber cutting operations.
  - (d) Helicopter logging operations.

**NOTE:** Where there is no through traffic, such as on a dead end road or where the property owner's permission or proper authority is granted to close a section of road, warning signs and barricades may be used instead of flagger(s).

- (2) Flaggers must wear vests of a high-visibility color and use a minimum 18-inch x 18-inch "STOP/SLOW" paddle to control traffic.
- (3) Warning signs and flagging activities along state and county roads must comply with the requirements of the Millennium Edition of the (FHWA) Manual of Uniform Traffic Control Devices (MUTCD), December 2000.

**Stat. Auth.:** ORS 654.025(2) and 656.726(4).

**Stats. Implemented:** ORS 654.001 through 654.295.

**Hist:** OR-OSHA Admin. Order 5-2003, f. 6/02/03, ef. 12/01/03.

## 437-007-0515 Signs.

(1) Warning signs must be prominently displayed a minimum of 300 feet in advance of forest activities which create hazardous conditions for road traffic.

(2) Warning signs must be removed or covered when forest activity operations are interrupted for an extended period.

(3) Warning signs must be worded to describe the hazard, type of operation or action to be taken.

**NOTE: Samples of operation specific sign wording:**

Lines Across Road

Contact Operator On Channel \_\_\_\_\_

Stop Do Not Proceed Without Contacting

\_\_\_\_\_

Timber Falling Ahead

Blasting

Logging Operations Ahead

Heavy Truck Traffic

CB Channel \_\_\_\_\_

(4) Warning signs must:

(a) Be a minimum dimension of 24-inch x 24-inch diamond.

(b) Have an orange background.

(c) Have 4-inch black letters.

(5) When stop signs are used they must:

(a) Be eight sided.

(b) Have a minimum height and width of 24 inches.

(c) Have a red background with 6-inch white letters for the "STOP" side.

(6) The "STOP/SLOW" paddle must:

(a) Be eight sided.

- (b) Have a minimum height and width of 18 inches.
- (c) Have a red background with 6-inch white letters for the “STOP” side.
- (d) Have an orange background with 6-inch black letters for the “SLOW” side.

**Stat. Auth.:** ORS 654.025(2) and 656.726(4).

**Stats. Implemented:** ORS 654.001 through 654.295.

**Hist:** OR-OSHA Admin. Order 5-2003, f. 6/02/03, ef. 12/01/03.

**VEHICLE GENERAL REQUIREMENTS /  
VEHICLE WARNING DEVICES /  
VEHICLE WINDSHIELDS,  
WINDOWS & MIRRORS**

**F**

**437-007-0520 Vehicle General Requirements.**

- (1) A positive engine shut-off must be provided within reach of the operator when in normal operating position.
- (2) Vehicles must be equipped with adequate steps, ladders, handholds, or grab bars to provide safe access and egress.
- (3) Steps must be constructed or treated with slip-resistant materials.
- (4) Vehicle seats must be securely fastened.
- (5) Doors must open easily.

**Stat. Auth.:** ORS 654.025(2) and 656.726(4).

**Stats. Implemented:** ORS 654.001 through 654.295.

**Hist:** OR-OSHA Admin. Order 5-2003, f. 6/02/03, ef. 12/01/03.

**437-007-0525 Vehicle Warning Devices.** All vehicles must be equipped with a horn or audible warning device which can be clearly heard above the surrounding noise in the vicinity of the vehicle.

**Stat. Auth.:** ORS 654.025(2) and 656.726(4).

**Stats. Implemented:** ORS 654.001 through 654.295.

**Hist:** OR-OSHA Admin. Order 5-2003, f. 6/02/03, ef. 12/01/03.

**437-007-0530 Vehicle Windshields, Windows and Mirrors.**

- (1) Vehicle windshields must be equipped with powered wipers.
- (2) Vehicles must be equipped with operable windshield defogging or defrosting equipment.
- (3) Defective or broken glass in a vehicle which impairs the vision of the operator or could cause injury to occupants of a vehicle must be replaced.
- (4) Deposits on glass which impair the vision of the operator must be removed.
- (5) Windshield and windows installed on vehicles must be safety glass which meets the requirements for safety glazing material used in motor vehicles, as defined in the American National Standards Institute, Safety Glazing Materials for Glazing Motor Vehicles Operating on Land Highways, Z26.1-1996, or a material which will furnish equivalent safety.

**F****VEHICLE WINDSHIELDS, WINDOWS &  
MIRRORS / VEHICLE PASSENGER  
COMPARTMENTS / VEHICLE BRAKES**Oregon Administrative Rules  
Oregon Occupational Safety  
and Health Division

(6) Vehicles must be equipped with an adjustable sun visor.

(7) Vehicles must be equipped with outside-mounted rear view mirrors on each side when the load or passengers obstruct the use of the rear view mirror located in the cab.

**Stat. Auth.:** ORS 654.025(2) and 656.726(4).

**Stats. Implemented:** ORS 654.001 through 654.295.

**Hist:** OR-OSHA Admin. Order 5-2003, f. 6/02/03, ef. 12/01/03.

**437-007-0535 Vehicle Passenger Compartments.**

(1) Floors and decks must be suitable for safe footing.

(2) All openings between enclosed passenger compartments and engine or exhaust from which fumes or gases may enter must be effectively sealed.

(3) Enclosed passenger compartments must be reasonably dust-proof and watertight.

(4) Floors and interior surfaces of passenger compartments must be free of protruding nails, screws, splinters or other objects which might cause injury.

**Stat. Auth.:** ORS 654.025(2) and 656.726(4).

**Stats. Implemented:** ORS 654.001 through 654.295.

**Hist:** OR-OSHA Admin. Order 5-2003, f. 6/02/03, ef. 12/01/03.

**437-007-0540 Vehicle Brakes.**

(1) All vehicles must have brakes which are capable of stopping the vehicle while fully loaded on any grade over which they are to be operated.

(2) All vehicles must have a parking brake that will hold the loaded vehicle on any grade which it is operated.

**Stat. Auth.:** ORS 654.025(2) and 656.726(4).

**Stats. Implemented:** ORS 654.001 through 654.295.

**Hist:** OR-OSHA Admin. Order 5-2003, f. 6/02/03, ef. 12/01/03.

**437-007-0545 Vehicle Exhaust Systems.**

- (1) Vehicles must have an exhaust system that is maintained in good repair.
- (2) Vehicles must be equipped with a muffler of the type recommended by the vehicle manufacturer.
- (3) Exhaust pipes must be located to direct the exhaust gases away from the operator and any passengers.
- (4) Any exhaust pipe which is exposed to contact must be insulated or isolated to protect workers from contact burns.

**Stat. Auth.:** ORS 654.025(2) and 656.726(4).  
**Stats. Implemented:** ORS 654.001 through 654.295.  
**Hist:** OR-OSHA Admin. Order 5-2003, f. 6/02/03, ef. 12/01/03.

**437-007-0550 Vehicle Guards and Controls.**

- (1) Vehicles with dump bodies must be equipped with a permanently attached, positive means of support that is capable of being secured in position to prevent the accidental lowering of the dump body.
- (2) Devices for supporting dump bodies must be used when:
  - (a) The dump body is raised and left unattended.
  - (b) Maintenance or inspection work is being done.
- (3) Operating levers controlling hoisting or dumping devices on haulage bodies must be equipped with a latch or other device which will prevent accidental starting or tripping of the mechanism.
- (4) Trip handles for tailgates and belly dump trailers must be located so personnel are in the clear when dumping.
- (5) All vehicles whose payload is loaded by means of cranes, power shovels, loaders or similar equipment must have a cab shield or canopy adequate to protect the operator from shifting or falling materials.
- (6) The backs of vehicle cabs which are exposed to shifting loads must be provided with a substantial bulkhead or similar device.

**Stat. Auth.:** ORS 654.025(2) and 656.726(4).  
**Stats. Implemented:** ORS 654.001 through 654.295.  
**Hist:** OR-OSHA Admin. Order 5-2003, f. 6/02/03, ef. 12/01/03.

**437-007-0555 Vehicle Safety Chains.****(1) Safety chains or cables must:**

- (a)** Have a tensile strength equivalent to the gross weight of the towed vehicle.
- (b)** Prevent the tow bar from dropping to the ground in the event the tow bar or coupling device fails.
- (c)** Be attached in a manner that provides sufficient strength to control the towed vehicle in event the tow bar or coupling device fails.
- (d)** Have no more slack than necessary to permit proper turning.

**Stat. Auth.:** ORS 654.025(2) and 656.726(4).

**Stats. Implemented:** ORS 654.001 through 654.295.

**Hist:** OR-OSHA Admin. Order 5-2003, f. 6/02/03, ef. 12/01/03.

**437-007-0560 Vehicle Seat Belts.**

**(1)** All vehicles (except those that were not originally equipped with seat belts) designed or used primarily to transport personnel or material over private or public roads must have seat belts.

**(2) For each vehicle equipped with a seat belt(s), the employer must:**

- (a)** Require all personnel to use seat belts when the vehicle is being operated.
- (b)** Require all personnel to tightly fasten seat belts when the vehicle is being operated.
- (c)** Maintain each seat belt in a serviceable condition.
- (d)** Replace each seat belt which has been removed from any vehicle that was equipped with seat belts at the time of manufacture.

**Stat. Auth.:** ORS 654.025(2) and 656.726(4).

**Stats. Implemented:** ORS 654.001 through 654.295.

**Hist:** OR-OSHA Admin. Order 5-2003, f. 6/02/03, ef. 12/01/03.

# VEHICLE INSPECTION, MAINTENANCE & REPAIR / VEHICLE OPERATION

# F

## **437-007-0565 Vehicle Inspection, Maintenance and Repair.**

(1) Vehicles must be checked at the beginning of each shift to assure that they are in safe operating condition.

**NOTE:** Pay particular attention to components such as tires, steering apparatus, lights and reflectors, brakes, boosters, brake hoses and connections, reaches, bunks, stakes, bunk blocks and couplings.

(2) Any defects found during inspection, which affect the safe operation of the vehicle, must be corrected before the vehicle is placed in service.

(3) Any vehicle which develops defects in parts vital to safe operation during a work shift must be removed from service until necessary repairs are made.

**Stat. Auth.:** ORS 654.025(2) and 656.726(4).

**Stats. Implemented:** ORS 654.001 through 654.295.

**Hist:** OR-OSHA Admin. Order 5-2003, f. 6/02/03, ef. 12/01/03.

## **437-007-0570 Vehicle Operation.**

(1) Vehicle operators must be knowledgeable of the manufacturer's recommendations for operation, maintenance, safe work practices, and operating procedures.

(2) Vehicles must be started and operated only by trained and authorized personnel.

(3) Vehicles must not be moved until all personnel, other vehicles and machines are in the clear.

(4) Vehicles must not be driven or backed up to anyone standing in between the vehicle and a stationary object.

(5) When vehicle operators do not have a clear view of the surface being traveled, they must be guided by a signal person.

(6) Any operator who has an obstructed view to the rear of a vehicle must sound an audible warning, that can be heard over the surrounding noise, before backing up unless the:

(a) Vehicle is backed up only when an observer signals the driver that it is safe to do so;  
or

(b) Operator verifies that nobody is behind the vehicle.

(7) When vehicles are parked, the parking brakes must be set before the operator leaves the operator's station.

**F****VEHICLE OPERATION /  
TRANSPORTATION OF PERSONNEL /  
FLAMMABLE & COMBUSTIBLE LIQUIDS**Oregon Administrative Rules  
Oregon Occupational Safety  
and Health Division

**NOTE:** When it is not feasible to apply or release parking brakes because of freezing conditions, chocking or blocking of the wheels or using other precautions is permissible.

**(8)** Vehicles must not be loaded beyond the designed capacity.

**(9)** Vehicle loads must be stable, well-balanced and secured.

**Stat. Auth.:** ORS 654.025(2) and 656.726(4).

**Stats. Implemented:** ORS 654.001 through 654.295.

**Hist:** OR-OSHA Admin. Order 5-2003, f. 6/02/03, ef. 12/01/03.

**437-007-0575 Transportation of Personnel.**

**(1)** Workers riding in motor vehicles must not stand while the vehicle is in motion.

**(2)** Flatbed and dump trucks must not be used to transport workers.

**(3)** Passengers must wait for the vehicle to come to a complete stop before boarding or leaving.

**(4)** When materials, equipment and tools of any type are transported in the same compartment with workers, the workers and driver must be protected from the hazards of materials, equipment or tools by substantial partitions or the securing of the load.

**(5)** Transported materials must not prevent doors of vehicle cabs from being opened.

**(6)** Compartments for workers must be kept in a clean and sanitary condition. Workers should assist in maintaining such conditions.

**Stat. Auth.:** ORS 654.025(2) and 656.726(4).

**Stats. Implemented:** ORS 654.001 through 654.295.

**Hist:** OR-OSHA Admin. Order 5-2003, f. 6/02/03, ef. 12/01/03.

**437-007-0580 Flammable and Combustible Liquids.**

**(1)** Flammable and combustible liquids must be stored in accordance with OAR 437, 2/H, Hazardous Materials, §1910.106, Flammable and Combustible Liquids.

**(2)** Containers of flammable and combustible liquids must be marked in accordance with OAR 437, 2/Z, §1910.1200, Hazard Communication.

**(3)** Smoking within 35 feet of vehicles being fueled is prohibited.

## FLAMMABLE & COMBUSTIBLE LIQUIDS

**F**

- (4) Fueling of vehicles within 35 feet of any open fires, flame or other sources of ignition is prohibited.
- (5) Vehicle engines, except diesel engines, must be shut off while being fueled.
- (6) Refilling tanks using liquefied petroleum gases must:
- (a) Only be done out-of-doors.
  - (b) Not exceed the maximum quantity of fuel recommended by the manufacturer.
- (7) Tanks, barrels or containers of gasoline, aviation fuels or diesel must not be hauled on vehicles transporting workers except when:
- (a) Carried in a suitable location outside the driver and passenger compartment or placed in a well-ventilated vapor-proof compartment.
  - (b) Secured to prevent shifting.
- (8) When fuels are hauled in containers of 5-gallon capacity or less, the container must be approved by a nationally-recognized testing lab, such as Underwriters Laboratory (UL), or Factory Mutual (FM).
- (9) Vehicles must be kept free of accumulated fuel and combustible liquids which may create a fire or other hazard.

**Stat. Auth.:** ORS 654.025(2) and 656.726(4).

**Stats. Implemented:** ORS 654.001 through 654.295.

**Hist:** OR-OSHA Admin. Order 5-2003, f. 6/02/03, ef. 12/01/03.

<b>F</b>		Oregon Administrative Rules Oregon Occupational Safety and Health Division
----------	--	--

# RIGGING AND RIGGING PRACTICES

# G

## TABLE OF CONTENTS

<b>437-007-0600</b>	Inspection and General Requirements for Rigging.....	G-1
<b>437-007-0605</b>	Out-of-Service Requirements for Wire Rope .....	G-1
<b>437-007-0610</b>	Line Cutting and Splicing.....	G-2
<b>437-007-0615</b>	Pressed Eyes and End Fittings .....	G-4
<b>437-007-0620</b>	Cable Clamps .....	G-4
<b>437-007-0625</b>	Mollies.....	G-5
<b>437-007-0630</b>	Connectors .....	G-6
<b>437-007-0635</b>	Shackles .....	G-6
<b>437-007-0640</b>	Metal Spar Guyline Safety Straps .....	G-10
<b>437-007-0645</b>	Chokers and Straps.....	G-11
<b>437-007-0650</b>	Guylines – General Requirements .....	G-13
<b>437-007-0655</b>	Guylines – Tail Tree Guying.....	G-14
<b>437-007-0660</b>	Intermediate Support Trees .....	G-15
<b>437-007-0665</b>	Anchoring .....	G-18
<b>437-007-0670</b>	Spiking and Releasing Spiked Guylines or Skylines .....	G-22
<b>437-007-0675</b>	Selecting, Preparing and Rigging Trees .....	G-23
<b>437-007-0680</b>	Blocks and Hanging Blocks.....	G-24
<b>437-007-0690</b>	Metal Towers .....	G-25

**G**

Oregon Administrative Rules  
Oregon Occupational Safety  
and Health Division

# INSPECTION & GENERAL REQUIREMENTS FOR RIGGING / OUT-OF-SERVICE REQUIREMENTS FOR WIRE ROPE

# G

## **437-007-0600 Inspection and General Requirements for Rigging.**

**(1)** A competent person must thoroughly inspect all:

**(a)** Blocks, butt rigging, shackles and other rigging for damaged, cracked or worn parts, loose nuts and bolts, and the need for lubrication before they are used.

**(b)** Wire rope (running lines), skylines, chokers, straps and guylines before they are used.

**(2)** Repairs or replacements must be made before the blocks, butt rigging, shackles, other rigging, guylines, or straps are used.

**(3)** Rigging and loads must not foul or saw against lines, straps, blocks, or other equipment when in use.

**Stat. Auth.:** ORS 654.025(2) and 656.726(4).

**Stats. Implemented:** ORS 654.001 through 654.295.

**Hist:** OR-OSHA Admin. Order 5-2003, f. 6/02/03, ef. 12/01/03.  
OR-OSHA Admin. Order 3-2004, f. 6/7/04, ef. 6/7/04.

## **437-007-0605 Out-of-Service Requirements for Wire Rope.**

**(1)** Wire rope must be repaired (spliced), re-socketed, or taken out of service when there is:

**(a)** Evidence of chafing, sawing, crushing, kinking, crystallization, bird-caging, corrosion, heat damage, or other damage that has weakened the rope structure, or

**(b)** One or more broken wire(s) at the base of a poured nubbin or end fitting, or

**(c)** Corroded, damaged, or improperly applied end connections, or

**(d)** 12 1/2 percent of the wires are broken within a distance of one lay.

# G

## OUT-OF-SERVICE REQUIREMENTS FOR WIRE ROPE / LINE CUTTING & SPLICING

Oregon Administrative Rules  
Oregon Occupational Safety  
and Health Division

**EXCEPTION:** *Out-of-service requirements do not apply to chokers, grapple opening lines, tag lines, cat and skidder winch lines, and droplines that are not used to move the carriage. However, in accordance with 437-007-0600, a competent person must inspect these cables daily and remove from service any that are unsafe.*

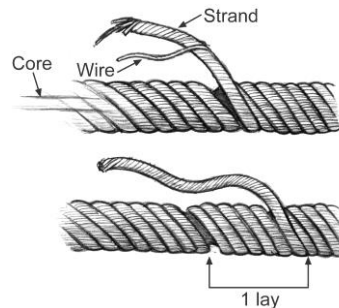

**Figure 7-1 – Wire Rope Out-of-Service**

**EXAMPLE 1:** A 6 x 19 Independent Wire Rope Core (IWRC) wire rope must be removed from service when 14 broken wires are found within the distance of one wire rope lay. [6 strands with 19 wires =  $114 \times 0.125$  (12 1/2%) = 14.25]

**EXAMPLE 2:** A 6 x 25 IWRC wire rope must be removed from service when 19 broken wires are found within the distance of one wire rope lay. [6 strands with 25 wires =  $150 \times 0.125$  (12 1/2%) = 18.75]

(2) Oversized trailer lift straps must be removed from service when the strap no longer has a breaking strength equal to five times the load to be lifted.

**Stat. Auth.:** ORS 654.025(2) and 656.726(4).

**Stats. Implemented:** ORS 654.001 through 654.295.

**Hist:** OR-OSHA Admin. Order 5-2003, f. 6/02/03, ef. 12/01/03.

OR-OSHA Admin. Order 3-2004, f. 6/7/04, ef. 6/7/04.

### 437-007-0610 Line Cutting and Splicing.

(1) Hard hammers must not be used when splicing or cutting wire rope with a wire axe.

(2) Eye protection must be used when cutting lines.

(3) Marlin spikes (needles) must be used when splicing.

(4) Short splices, eye-to-eye splices, cat's paws, and knots are prohibited except when used to move nonload-bearing lines.

(5) Knots may be used on single drum tractor winch lines, grapple pickup lines and carriage droplines when the knot is tied on the end of the dropline/pickup line. The knot must be pulled as tight as possible and the ends trimmed in accordance with Table 7-2.

(6) Eye splices in wire rope 1/2-inch or less in diameter must be tucked at least two times when used as haywire (strawline).

- (7) Eye splices in all regular lay lines and straps must be tucked at least three times.
- (8) Eye splices in lang lay lines must be tucked at least four times.
- (9) When flemish (rolled) eye splices are used on load bearing lines, the strand ends must be secured by:
- (a) Hand tucking each strand three times, or
  - (b) Applying a compression fitting (pressed eye fittings).
- (10) Long splices must be used for permanently joining regular lay running line.

**Exception:** When using mechanical slack pulling carriages, jump splices may be used to connect the main and slack pulling lines, and tucked splices may be used to attach drop lines to main lines only if the:

1. Crew members are notified of the splices being used.
2. Yarder boom sheaves are of the Tommy Moore type.
3. Splices are on the yarder side of the carriage.
4. Lines are arranged so splices do not go through the carriage.
5. Spliced strands are trimmed at 6 inches.
6. Splices are inspected at least once daily for signs of excessive wear or failure.
7. Defective splices are immediately repaired (spliced) or removed from service.
8. Jump splices connecting main and slack pulling lines are between 30 inches and 48 inches long and tucked at least three times.
9. Splices attaching drop lines to main lines are tucked at least three times.

- (11) Follow Table 7-1 for the length of line strand to unravel to make a long splice in wire rope. The full length of the splice must be twice the length of the unraveled rope.

Rope Diameter	Unravel	Rope Diameter	Unravel
3/4-inch	15 feet	1 3/8-inch	28 feet
7/8-inch	18 feet	1 1/2-inch	30 feet
1-inch	20 feet	1 5/8-inch	33 feet
1 1/8-inch	23 feet	1 3/4-inch	35 feet
1 1/4-inch	25 feet	2 inches	40 feet

- (12) Wire strand ends must be trimmed to the length shown in Table 7-2.

Wire Rope Diameter	Length Of Strand Ends
up to 5/8-inch	2 inches
3/4 to 1-inch	6 inches
1 1/8-inch and larger	8 inches

**Stat. Auth.:** ORS 654.025(2) and 656.726(4).  
**Stats. Implemented:** ORS 654.001 through 654.295.  
**Hist:** OR-OSHA Admin. Order 5-2003, f. 6/02/03, ef. 12/01/03.

# G

## PRESSED EYES & END FITTINGS / CABLE CLAMPS

Oregon Administrative Rules  
Oregon Occupational Safety  
and Health Division

### 437-007-0615 Pressed Eyes and End Fittings.

- (1) Pressed eyes must not be used for skyline eyes that will be crossed with loaded carriages.
- (2) Quick nubbins must not be used as guyline and skyline end fittings.
- (3) For rigging made up after December 1, 2003, standard sized ferrules must be used when nubbins are poured on wire rope that exceeds the rated breaking strength of 1 1/8-inch diameter extra improved plow steel.
- (4) Poured nubbin ferrules must be stamped with the date they were poured.
- (5) The recommendations of the manufacturer must be followed in attaching sockets and similar end fastenings.

**Stat. Auth.:** ORS 654.025(2) and 656.726(4).  
**Stats. Implemented:** ORS 654.001 through 654.295.  
**Hist:** OR-OSHA Admin. Order 5-2003, f. 6/02/03, ef. 12/01/03.  
OR-OSHA Admin. Order 3-2004, f. 6/7/04, ef. 6/7/04.

### 437-007-0620 Cable Clamps.

- (1) The use of cable clips or clamps for joining lines is prohibited, except where used for transferring slack lines from one place to another.

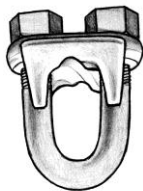

**Figure 7-2**  
**Wire Rope U-Bolt Clip**



**Figure 7-3**  
**Wire Rope Fist Grip Clip**

- (2) When U-bolt wire rope clips are used, the following requirements apply:

- (a) When used for eye splices, the U-bolt wire rope clip must be attached so that the “U” section is in contact with the dead or short end of the rope;

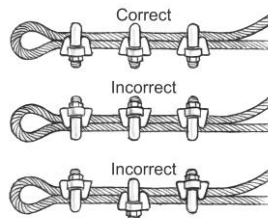

**Figure 7-4 – U-Bolt Clip Installation**

**(b)** U-bolt wire rope clips must be spaced at least six rope diameters apart to obtain the maximum holding power. Nuts must be tightened evenly and tightened again after application of the first sustained load. After the rope has been used and is under tension, the clips must be tightened again to take up any looseness caused by the tension reducing the rope diameter;

**(c)** When high strength wire rope is used, one more U-bolt wire rope clip must be added for each grade above improved plow steel; and

**(d)** U-bolt wire rope clips must not be used to form eyes on running lines, skylines, or straps.

**(3)** When U-bolt wire rope clips are used to form eyes, Table 7-3 must be used to determine the number and spacing of clips.

**TABLE 7-3  
NUMBER AND SPACING OF U-BOLT WIRE ROPE CLIPS**

Improved Plow Steel Rope Diameter In Inches	Drop Forge Number of Clips	Other Material Number of Clips	Minimum Spacing In Inches
3/8 to 5/8	3	4	3 3/4
3/4	4	5	4 1/2
7/8	4	5	5 1/4
1	5	6	6
1 1/8	6	6	6 3/4
1 1/4	6	7	7 1/2
1 3/8	7	7	8 1/4
1 1/2	7	8	9

**Stat. Auth.:** ORS 654.025(2) and 656.726(4).  
**Stats. Implemented:** ORS 654.001 through 654.295.  
**Hist:** OR-OSHA Admin. Order 5-2003, f. 6/02/03, ef. 12/01/03.

### 437-007-0625 Mollies.

**(1)** Mollies must not be used to connect eyes of load-bearing lines.

**(2)** Mollies or cold shuts must not be used in butt rigging as a load-bearing connection.

**(3)** The use of mollies for attaching guylines is prohibited.

**(4)** Mollies must be rolled in with the lay of the line.

**(5)** Mollies, latchpins, or cotterkeys must be large enough to retain the shackle pin.

**Stat. Auth.:** ORS 654.025(2) and 656.726(4).  
**Stats. Implemented:** ORS 654.001 through 654.295.  
**Hist:** OR-OSHA Admin. Order 5-2003, f. 6/02/03, ef. 12/01/03.

**437-007-0630 Connectors.**

(1) Guyline extensions must be connected by:

- (a) A shackle using a safety pin connecting spliced and/or pressed eyes, or
- (b) Poured nubbins and a double-end hook.

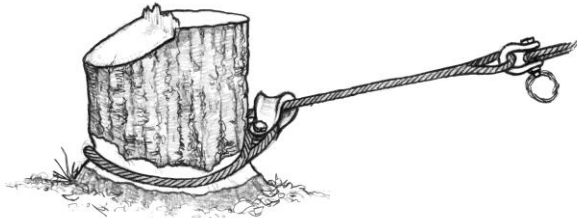

**Figure 7-5 – Guyline  
Connectors – Spliced Eyes**



**Figure 7-6 – Guyline  
Connectors – Poured Nubbins**

(2) Guyline extension connectors must have at least 1 1/2 times the strength of the guyline.

**Stat. Auth.:** ORS 654.025(2) and 656.726(4).  
**Stats. Implemented:** ORS 654.001 through 654.295.  
**Hist:** OR-OSHA Admin. Order 5-2003, f. 6/02/03, ef. 12/01/03.

**437-007-0635 Shackles.**

(1) Shackle pin diameter must be:

- (a) 1/8-inch larger than the indicated shackle size for shackles up to 1 3/4 inches.
- (b) 1/4-inch larger than the indicated shackle size for shackles 1 3/4-inch up through 3 inches.

(2) Replacement shackle pins must meet the manufacturer's original specifications for strength and design for the size of shackle being used.

(3) Shackle pins and nuts must be replaced when the threads are worn or stripped.

(4) Worn shackle pins must be replaced when the original diameter is reduced by 15 percent.

(5) The opening size between the jaws of shackles used to hang blocks, jacks, rigging, and join or attach lines, cannot be more than 1-inch greater than the size of the line, swivel, shackle, or similar device to which it is attached.

# SHACKLES

# G

(6) Safety pins must secure shackles used to hang blocks, jacks, or rigging on trees, anchor guylines and join guyline or deadman strap eyes.



**Figure 7-7 – Shackle – Safety Pin**

(7) When skylines are attached with a shackle using a knockout pin, the pin must be one size larger than the skyline and secured with a molly, latchpin, or cotterkey. (See Figures 7-8 and 7-9.)

(8) Sleeve shackles or choker bells must be used where choked lines are permitted.

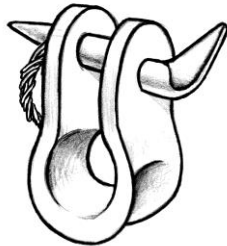

**Figure 7-8  
Shackle – Sleeve with Knockout Pin**



**Figure 7-9  
Shackle – Bell with Knockout Pin**

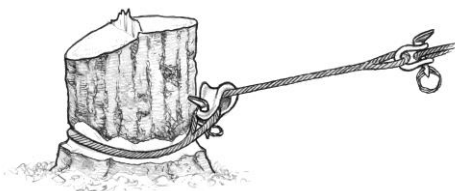

**Figure 7-10 – Skyline  
Attachments with Knockout Pins**



**Figure 7-11 – Shackle –  
Sleeve with Safety Pin**

(9) When a line is passed around an anchor without the use of a strap, the shackle pin must be inserted through the line eye and the “U” part of the shackle placed around the bight of the line.

- (10) Sleeve shackles must not be used to join two or more eyes together.
- (11) A flush pin, straight-sided shackle must be used to connect the eyes of lines if:
- (a) The shackle will be crossed by a sheave, or
  - (b) A sheave will be crossed by the shackle.

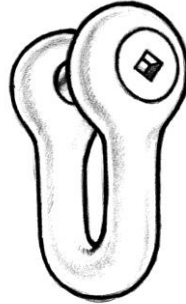

Figure 7-12 – Shackle – Flush Pin, Straight Side

- (12) When shackles are crossed by carriages, the pin must be facing the landing.
- (13) Shackles used to join three or more lines must be hung with the:
- (a) Pin through the single eye.
  - (b) “U” part through two or more line eyes.
- (14) When attaching a guylines, mainline, or skyline eye to two or more strap eyes, the:
- (a) Shackle pin must be placed through the guylines, mainline, or skyline eye.
  - (b) “U” part of the shackle must be placed through the strap eyes.
- (15) After a strap is passed around an anchor and the two eyes are contained in the “U” part of the shackle, the angle created by the strap eyes must not be greater than 90 degrees.

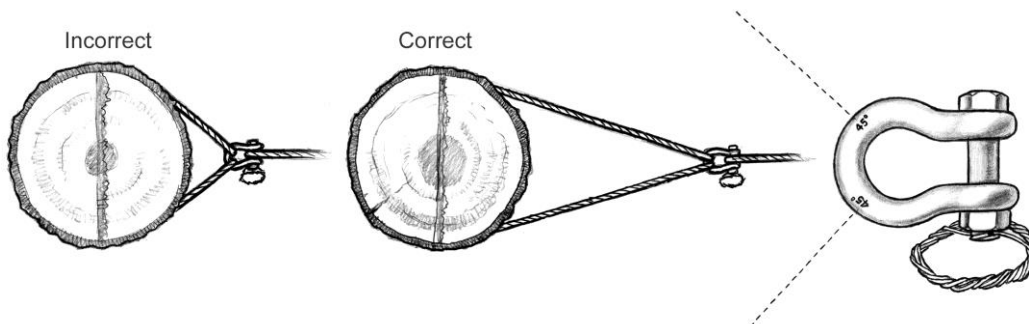

Figure 7-13 – Shackle – Straps within 90 Degrees

# SHACKLES

# G

**NOTE:** If the angle created by the strap eyes is greater than 90 degrees, the strap is too short. The shackle containing the strap eyes should be hung at least half the diameter of the anchor away from the anchor.

**(16)** Shackles used to connect tipping plate anchor lines to the eye of a guyline, mainline, or skyline must be:

- (a)** 1/8-inch larger than the largest line.
- (b)** Rated for a load equal to or greater than the expected working load.
- (c)** Large enough to accommodate all line eyes.

**(17)** Shackles attached to tipping plate anchors must have the shackle pins inserted through the anchor pad-eyes.

**(18)** A shackle must have a rated breaking strength greater than the rated breaking strength of the line that they are used with.

**(19)** The manufacturer's rated breaking strength of shackles must be used in determining oversize requirements when the make, size and steel classification of the shackle can be identified.

**(20)** Shackles listed in Tables 7-4, 7-5 and 7-6 must be made of alloy steel which develops 120,000 PSI ultimate tensile strength or better.

**NOTE:** Shackles sizes are listed for extra improved plow steel wire rope.

**(21)** The minimum size of shackles required to hang or attach single sheave blocks or jacks are shown in Table 7-4.

Wire Rope Size In Inches	Shackle Size In Inches	Wire Rope Size In Inches	Shackle Size In Inches
1/2	3/4	1	1 3/8
9/16	7/8	1 1/8	1 1/2
5/8	7/8	1 1/4	1 3/4
3/4	1 1/8	1 3/8	1 7/8
7/8	1 1/8	1 1/2	2 1/4

# G

## SHACKLES / METAL SPAR GUYLINE SAFETY STRAPS

Oregon Administrative Rules  
Oregon Occupational Safety  
and Health Division

(22) The minimum size of shackles required for joining or attaching lines are shown in Table 7-5.

Wire Rope Size In Inches	Shackle Size In Inches	Wire Rope Size In Inches	Shackle Size In Inches
1/2	5/8	1	1 1/4
9/16	3/4	1 1/8	1 3/8
5/8	7/8	1 1/4	1 1/2
3/4	1	1 3/8	1 5/8
7/8	1 1/8	1 1/2	2

(23) The minimum size of flush pin straight-sided shackles for joining or attaching skyline extensions are shown in Table 7-6.

Wire Rope Size In Inches	Shackle Size In Inches	Wire Rope Size In Inches	Shackle Size In Inches
1/2	5/8	1	1 1/8
9/16	3/4	1 1/8	1 1/4
5/8	3/4	1 1/4	1 3/8
3/4	7/8	1 3/8	1 1/2
7/8	1	1 1/2	1 5/8

Stat. Auth.: ORS 654.025(2) and 656.726(4).  
Stats. Implemented: ORS 654.001 through 654.295.  
Hist: OR-OSHA Admin. Order 5-2003, f. 6/02/03, ef. 12/01/03.

### 437-007-0640 Metal Spar Guyline Safety Straps.

(1) A guyline safety strap or equivalent device must be installed at the top of metal spars to prevent guylines from falling vertically more than 5 feet in case of structural or mechanical failure of the guyline attachment.

(2) Metal spar guyline safety straps or equivalent devices must be equal to the individual strength of any guyline being used.

(3) The ends of metal spar guyline safety straps must be connected to each other, or installed per manufacturer's instructions.

**NOTE:** Two eyes secured with a shackle or two poured nubbins secured in a connector are acceptable for the connections.

(4) The use of cable clips or clamps for joining the ends of metal spar guyline safety straps is prohibited.

Stat. Auth.: ORS 654.025(2) and 656.726(4).  
Stats. Implemented: ORS 654.001 through 654.295.  
Hist: OR-OSHA Admin. Order 5-2003, f. 6/02/03, ef. 12/01/03.  
OR-OSHA Admin. Order 2-2005, f. 5/27/05, ef. 6/1/05.

# CHOKERS AND STRAPS

# G

## 437-007-0645 Chokers and Straps.

- (1) In highlead logging, chokers must be at least one size smaller than the mainline.
- (2) Straps must be equivalently sized for the line they support, e.g., Extra Improved Plow Steel (EIPS) line requires EIPS straps or equivalent strength material.
- (3) Straps or chokers used at or near the ground to hang or support blocks, jacks, tree shoes, or rigging must be sized in accordance with Table 7-7.

**Table 7-7**  
**Strap Sizes For Rigging At Or Near The Ground**

Skyline or Running Line Size In Inches	Block Hung In Both Eyes	Block Hung In Single Eye	Skyline or Running Line Size In Inches	Block Hung In Both Eyes	Block Hung In Single Eye
5/16	1/4	1/2	7/8	7/8	1 1/4
3/8	1/4	9/16	1	1	1 3/8
7/16	5/16	5/8	1 1/8	1	not permitted
1/2	3/8	3/4	1 1/4	1	not permitted
9/16	7/16	7/8	1 3/8	1	not permitted
5/8	5/8	1	1 1/2	1 1/8	not permitted
3/4	3/4	1 1/8	1 5/8	1 1/4	not permitted

- (4) Straps or chokers used to hang or support blocks, jacks, tree shoes, or rigging in tail and intermediate trees must be sized in accordance with Table 7-8.

**Table 7-8**  
**Strap Sizes For Rigging Hung In Tail and Intermediate Support Trees**

Skyline Or Running Line Size In Inches	Block Hung In Both Eyes	Block Hung In Single Eye**
5/16	1/4	5/16
3/8	1/4	3/8
7/16	5/16	3/8
1/2	5/16	1/2
9/16	3/8	1/2
5/8	3/8	9/16
3/4	1/2	3/4
7/8	9/16	3/4
1	5/8	7/8
1 1/8	3/4	1
1 1/4	3/4	1 1/8
1 3/8	7/8	not permitted
1 1/2	1	not permitted
1 5/8	1	not permitted
2	1 1/8	not permitted

**NOTE:** Flat angle on skyline through block or jack.

(5) When a two part strap or two chokers are used to hang a block, jack, tree shoe, or rigging both eyes or ends must be under approximately equal tension.

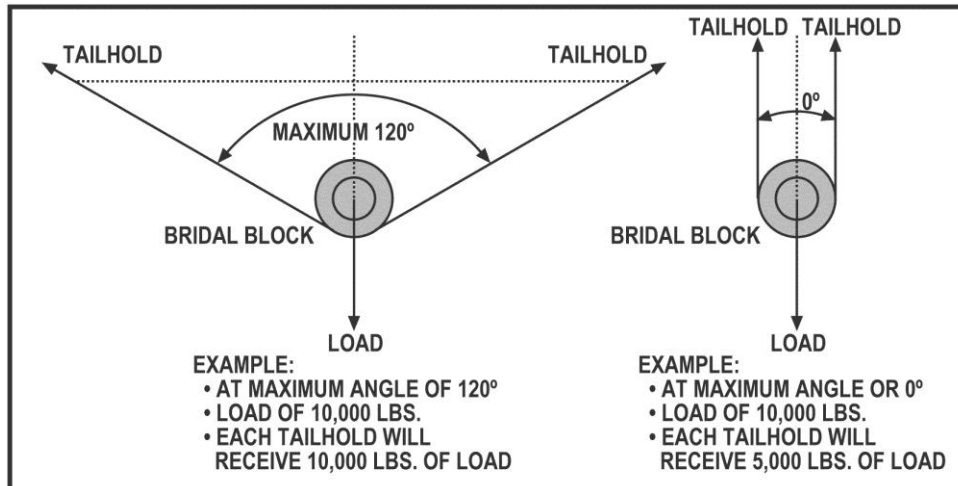

Figure 7-15 – Straps – Line Tension Bridal

(6) When two equal length chokers are used to hang a block, jack, tree shoe, or rigging in lieu of one choker to gain extra breaking strength, they must be:

- (a) Arranged as a swede-type connection.
- (b) Considered as a block hung in two eyes for Table 7-8.

(7) For straps hung in trees where the interior angle or angles create excessive loading on the strap as shown in Figure 7-14 additional precautions must be taken, such as using a larger strap, lightening loads, moving the carriage ahead on the line, and so forth to reduce the load on the strap.

Figure 7-14 – Straps – Line Tension

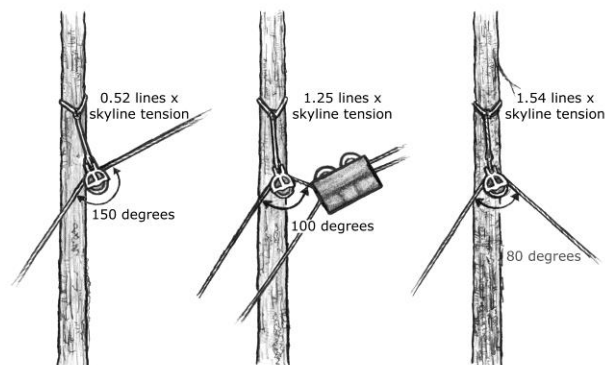

(8) Straps made of synthetic materials must be arranged so the straps cannot ride up or down from their intended position.

# CHOKERS & STRAPS / GUYLINES – GENERAL REQUIREMENTS



**(9)** Straps made of synthetic materials must be used and replaced in accordance with the manufacturer's recommendations.

**Stat. Auth.:** ORS 654.025(2) and 656.726(4).

**Stats. Implemented:** ORS 654.001 through 654.295.

**Hist:** OR-OSHA Admin. Order 5-2003, f. 6/02/03, ef. 12/01/03.

## **437-007-0650 Guylines – General Requirements.**

**(1)** Splicing of guylines is prohibited except to make an eye.

**(2)** Guylines used to stabilize logging machines must be at least of the size, strength and number recommended by the machine manufacturer.

**(3)** Load-bearing guyline angles must not be greater than 50 degrees measured horizontally or that recommended by the machine manufacturer. If suitable anchors are not available or the terrain is so steep that the guyline angle exceeds 50 degrees or the machine manufacturer's recommendation, additional precautions must be taken, such as rearranging guylines to oppose the load, adding an additional guyline to oppose the load, or narrowing yarding roads.

**(4)** Tail and intermediate support tree guylines must be:

**(a)** Arranged and adjusted so they share the load when lines are tensioned.

**(b)** Kept securely tightened during the yarding process.

**(c)** Made of the same strength material as the line hung in the tree or larger size guylines must be used to provide the same relative strength.

*Example: In 437-007-0650(4)(c), a 1-inch swaged skyline requires guylines equivalent in strength to 5/8-inch swaged guylines.*

**(5)** When using tail or intermediate support trees and the line hung in the tree is:

**(a)** 5/8-inch or less, guylines must be at least 3/8-inch.

**(b)** Greater than 5/8-inch and less than 1-inch, guylines must be at least 1/2-inch.

**(c)** 1-inch and larger, guylines must be at least 5/8-inch.

**(6)** A skyline must not be considered a guyline.

**(7)** Machines and equipment used for yarding that are specifically designed to be self-stabilizing during operation may be used without guyline(s).

**NOTE:** Hydraulic excavator-based log loading machines may yard logs without using guylines.

- (8) Guylines made of synthetic materials, including the end connectors, must have the equivalent strength capacities of wire rope.
- (9) The manufacturer's recommendations for out-of-service requirements of synthetic materials must be followed.
- (10) When guylines are required for towers they must be positioned according to Appendix 7-I, Figure 7-39 through Figure 7-50.
- (11) Tail or intermediate support tree guylines must not be pretensioned beyond the point of tree stability before the load is applied. (See Figure 7-18.)
- (12) Trees and unintentional siwashes must not interfere with the proper alignment, placement, or tightening of guylines.
- (13) Guylines must be hung in a manner to prevent a bight or fouling when they are tightened.

**Stat. Auth.:** ORS 654.025(2) and 656.726(4).

**Stats. Implemented:** ORS 654.001 through 654.295.

**Hist:** OR-OSHA Admin. Order 5-2003, f. 6/02/03, ef. 12/01/03.  
OR-OSHA Admin. Order 3-2004, f. 6/7/04, ef. 6/7/04.  
OR-OSHA Admin. Order 2-2005, f. 5/27/05, ef. 6/1/05.

### 437-007-0655 Guylines - Tail Tree Guying.

- (1) Except as provided for in rule (2) and (5) of this section, a minimum of two guylines must be used on tail trees and located within guying zones to oppose the forces as shown in Figure 7-16 (azimuths 130-150 and 210-230 degrees).

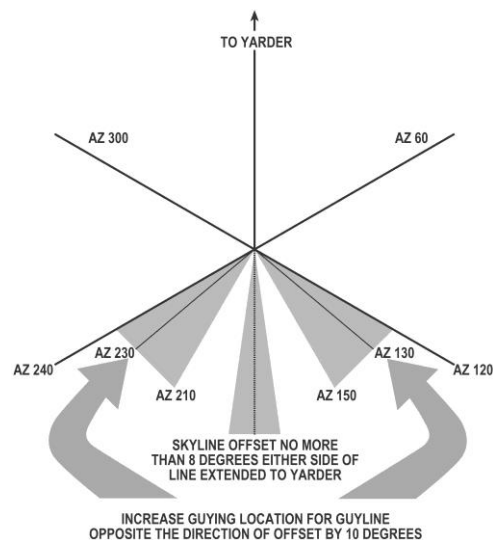

**Figure 7-16 – Guylines – Tail Trees**

(2) When the angle of the lines between the tail tree and a tail hold produces an offset of more than 8 degrees between the lines as they enter and leave the tail tree, then at least three guylines are required.

(3) If a suitable anchor is not available within a specified guying zone, two guylines may be used in lieu of one guyline for that zone, provided a guyline is placed on both sides of, and as near as possible, to the affected guying zone.

(4) When additional guylines are needed in a tree, they must be placed to oppose the yarding forces.

(5) Guylines are not required when at the point of rigging attachment the tail tree does not move more than its diameter in the direction of load as shown in Figure 7-18 and the:

(a) Tail tree is not within reach of workers.

(b) Resulting line movement would not pose a hazard to workers if the tail tree failed.

**Stat. Auth.:** ORS 654.025(2) and 656.726(4).

**Stats. Implemented:** ORS 654.001 through 654.295.

**Hist:** OR-OSHA Admin. Order 5-2003, f. 6/02/03, ef. 12/01/03.  
OR-OSHA Admin. Order 3-2004, f. 6/7/04, ef. 6/7/04.

## 437-007-0660 Intermediate Support Trees.

(1) Intermediate support trees must be rigged so:

(a) Horizontal carriage clearance at the base of the intermediate support tree(s) is sufficient for the turn of logs to pass the support tree(s).

(b) The jackline is a single piece of line that provides strength equal to a line 1/8-inch larger than the tong or skidding line. (Figures 7-17, 7-19 and 7-20.) Extensions may be attached to the anchor end of the jack-line.

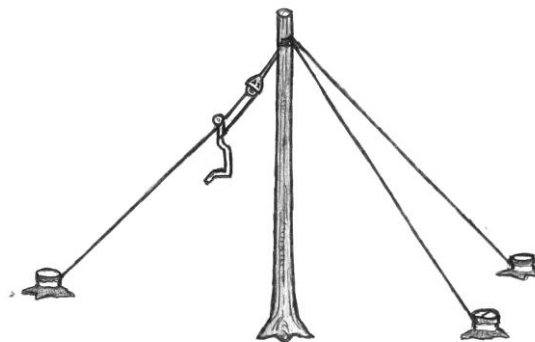

Figure 7-17 – Intermediate Support Tree – Vertical

# G

## INTERMEDIATE SUPPORT TREES

Oregon Administrative Rules  
Oregon Occupational Safety  
and Health Division

- (2) Vertical support trees must be firmly rooted.
- (3) The base of all leaning tree supports must be prevented from moving by:
  - (a) Retaining 20 percent of the stump diameter in holding wood; or
  - (b) Other suitable rigging arrangements.
- (4) Single tree intermediate supports must be guyed as follows:
  - (a) For skylines 1-inch and smaller use the rigging configuration in Figure 7-17:
    - (A) No guylines are required when at the point of rigging attachment the tree does not move more than its diameter in the direction of load as shown in Figure 7-18.
    - (B) If the tree moves more than one diameter at the point of rigging attachment, then a guyline of the size called for in 437-007-0650(4) must be rigged to oppose the yarding forces.

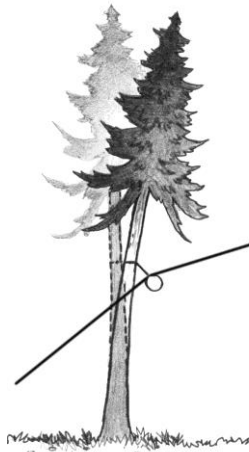
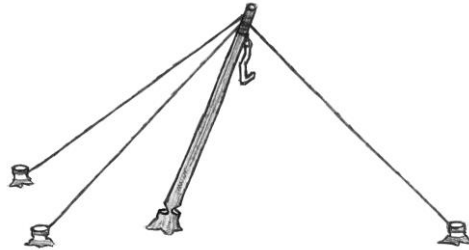

**Figure 7-18 –Tail and Intermediate Support Tree Stability**

- (b) For all skylines larger than 1-inch and for skylines rigged as in Figure 7-17.
  - (A) Two guylines are needed of the sizes called for in 437-007-0650(4)(c).
  - (B) The guylines must be rigged according to 437-007-0655(4) if the tree is not stable according to Figure 7-18.
- (c) For all leaning tree intermediate supports using the rigging configuration of Figure 7-19, a minimum of three guylines must be used.

**(A)** Two guylines of the sizes called for in 437-007-0650(4)(c) must be rigged according to Appendix 7-I, Figure 7-42.

**(B)** A snap guyline of at least 3/8-inch diameter must be placed opposite the two load-bearing guylines.



**Figure 7-19 – Intermediate Support Tree – Leaning**

**(5)** Double tree supports must be rigged (see Figure 7-20) so the:

**(a)** Angle of the block to the center of the support line:

**(A)** Is 10 degrees in any direction when skylines 1 1/8-inch and smaller are used, or

**(B)** Has deflection in the direction of the jack which does not exceed 10 degrees when skylines larger than 1 1/8-inch are used.

**(b)** Loaded support trees do not displace more than 2 feet at the point of rigging attachment.

**(c)** Minimum and maximum heights of the jack relative to the height of the block is as shown below for double tree intermediate support systems.

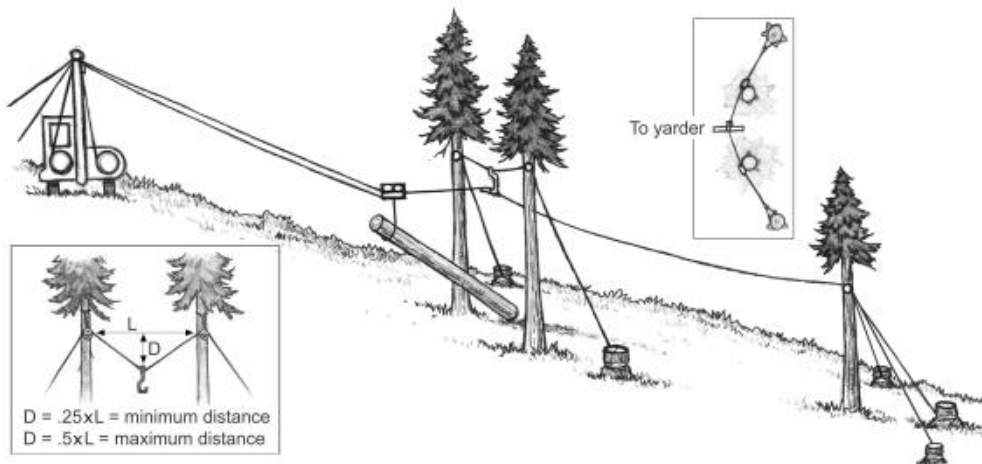

**Figure 7-20 – Intermediate Support – Double Tree**

# G

## INTERMEDIATE SUPPORT TREES / ANCHORING

Oregon Administrative Rules  
Oregon Occupational Safety  
and Health Division

(6) Double tree supports must be guyed as follows:

(a) For skyline sizes equivalent to 1 1/8-inch improved plow steel (IPS) and less, no guys are required;

(b) For skyline sizes equivalent to those larger than 1 1/8-inch IPS as shown in Appendix 7-I, Figure 7-39.

**Stat. Auth.:** ORS 654.025(2) and 656.726(4).

**Stats. Implemented:** ORS 654.001 through 654.295.

**Hist:** OR-OSHA Admin. Order 5-2003, f. 6/02/03, ef. 12/01/03.

OR-OSHA Admin. Order 3-2004, f. 6/7/04, ef. 6/7/04.

OR-OSHA Admin. Order 2-2005, f. 5/27/05, ef. 6/1/05.

### 437-007-0665 Anchoring.

(1) A competent person must carefully choose skyline, guyline and running line anchors for position and strength.

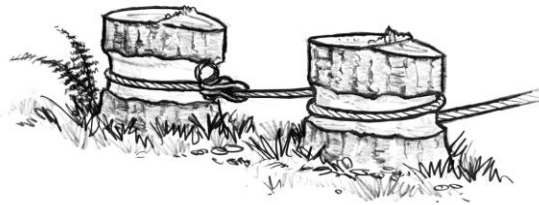

7. Figure 7-21 – Stump Tie Back Anchor

(2) A competent person must inspect anchors while the operation is in progress. When necessary, anchors must be tied back or changed.

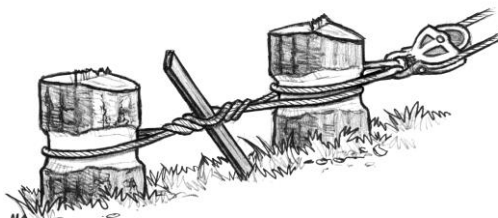

Figure 7-22 – Stump Twister Anchor

(3) Unstable yarder guyline anchors must be immediately corrected.

(4) Stump anchors must be notched to a depth not greater than is necessary to safely secure the line to the stump.

(5) Deadman anchors must have:

(a) Straps or lines equal in strength to the guyline, skyline, or mainline to attach the line to a deadman.

(b) Deadman anchor strap or line connectors visible for inspection.

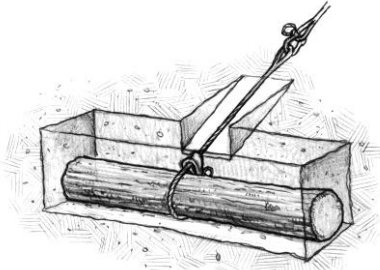

Figure 7-23 – Deadman Anchor

(6) When a standing tree is used as an anchor:

(a) The line or strap must be attached to the base of the tree.

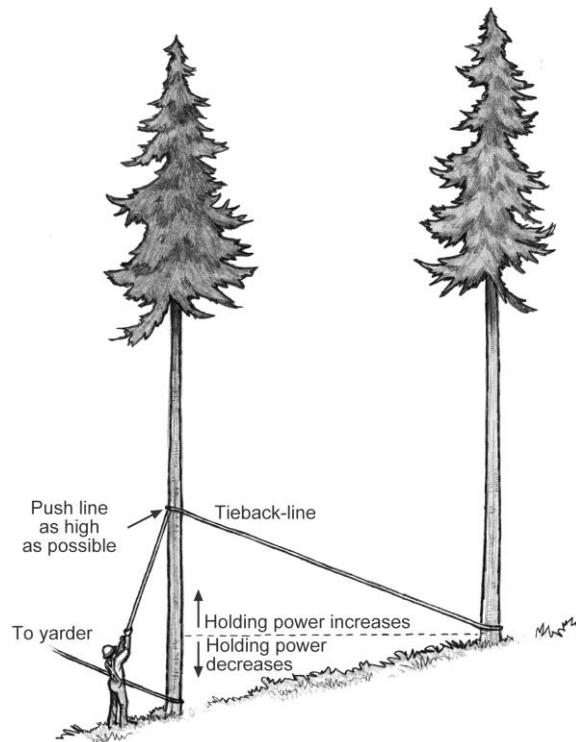

Figure 7-24 – Tree Tie Back Anchor

(b) The tree must be tied back if it is within reach of any worker, the landing area, or haul road.

# G

## ANCHORING

Oregon Administrative Rules  
Oregon Occupational Safety  
and Health Division

*NOTE: In some cases, the base of a standing tree(s) that is used as an anchor may also need to be tied-back.*

**(c)** Affected personnel must be notified of the standing tree anchor and the potential failure zone.

*NOTE: See the potential failure zone requirements listed in 437-007-0927(1) through (7).*

**(7)** The use of machines for anchoring guylines, skylines, or corner blocks must be done only under the supervision of a competent person.



**Figure 7-25 – Log Loader Anchor**

**(a)** When determining if the machine is a suitable anchor, the competent person must consider:

- (A)** The size and weight of the machine.
- (B)** The size of the line to be attached.
- (C)** The type of logging system to be used.
- (D)** The condition of the soil and slope of the ground.
- (E)** The availability of holding aids, such as road embankments or stumps.
- (F)** The skyline, guyline, or running line angle from the horizontal and vertical.
- (G)** Any other factors which would affect the stability of the machine anchor.

**(b)** Line attachment points on the machine must be determined by a qualified person.

**(c)** Machines that are used as mobile tail anchors and are stabilized with a guyline(s) must be guyed in accordance with OAR 437-007-0650(1), (2) and (3).

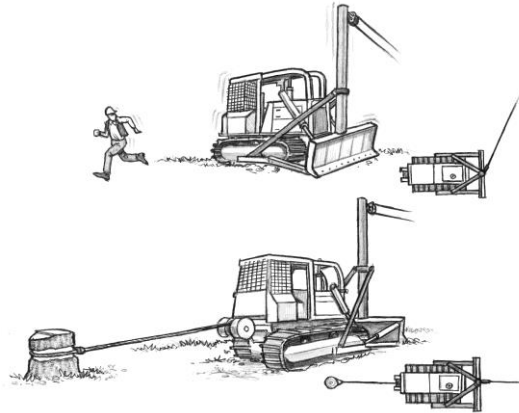

**Figure 7-26 – Tailhold Cat Anchor**

**(8)** Rock bolt anchors must be installed, grouted, tested and maintained in accordance with the manufacturer's recommendations.

**(9)** Artificial earth anchors must be installed and used in accordance with their design specifications and manufacturer's recommendations.

**(10)** When using tipping plate anchors:

**(a)** Guylines, skylines, or mainlines must not be directly attached to the anchors.

**(b)** The combined strength of straps or lines attached to multiple anchors must be equal in strength to the guyline, skyline, or mainline.

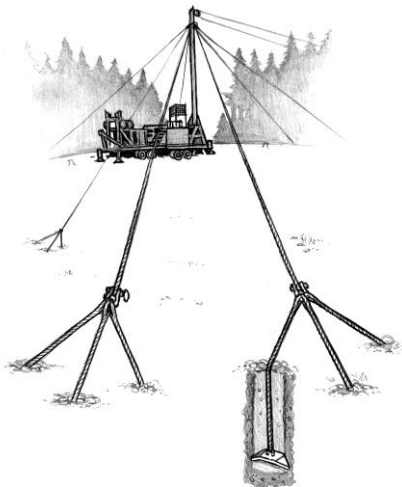

**Figure 7-27 – Tipping Plate Anchor**

# G

## ANCHORING / SPIKING & RELEASING SPIKED GUYLINES OR SKYLINES

Oregon Administrative Rules  
Oregon Occupational Safety  
and Health Division

(c) Shackles used to connect straps to the anchors must be secured with a safety pin.

*NOTE: This connection will not be visible for inspection.*

**Stat. Auth.:** ORS 654.025(2) and 656.726(4).

**Stats. Implemented:** ORS 654.001 through 654.295.

**Hist:** OR-OSHA Admin. Order 5-2003, f. 6/02/03, ef. 12/01/03.

OR-OSHA Admin. Order 2-2005, f. 5/27/05, ef. 6/1/05.

### 437-007-0670 Spiking and Releasing Spiked Guylines or Skylines.

(1) Spiked guylines or skylines must be anchored with at least two and one-half wraps around the stump. The first wrap must be secured with at least eight spikes or six staples. The second wrap must be secured with at least three spikes. The last, or top wrap, must be secured with eight spikes or six staples. (See Figure 7-28.)

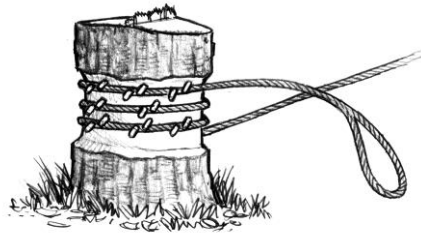

Figure 7-28 – Spiked Guylines and Skylines

(2) All the bark must be removed from the stump where the line is wrapped and spiked.

(3) Employees must not stand close to the stump or tree or in the bight of the lines as the guyline or skyline wraps are being tightened.

(4) When removing spiked guylines or spiked skylines from stumps or trees, a reverse safety wrap (Figure 7-29) must be put on and secured before loosening the last wrap, or the skyline or guyline must be held while the spikes are removed from the last wrap, and snubbed until the tension is relieved.

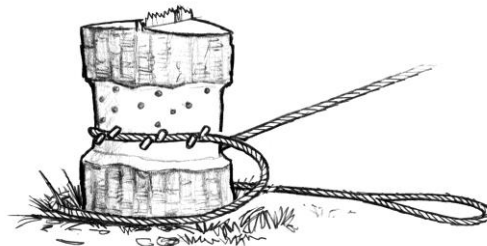

Figure 7-29 – Spiked Guyline Reverse Safety Wrap

## SPIKING & RELEASING SPIKED GUYLINES OR SKYLINES / SELECTING, PREPARING & RIGGING TREES

# G

(5) A competent person must be in charge of loosening spiked guylines or skylines, using all precautions and giving warning before lines are released. Safety holdbacks must be used when necessary.

**Stat. Auth.:** ORS 654.025(2) and 656.726(4).

**Stats. Implemented:** ORS 654.001 through 654.295.

**Hist:** OR-OSHA Admin. Order 5-2003, f. 6/02/03, ef. 12/01/03.

### 437-007-0675 Selecting, Preparing and Rigging Trees.

(1) Tail and intermediate support trees must be carefully chosen by a competent person based on position and strength necessary to support the imposed loads.

(2) Raised trees must be identified and marked as such.

(3) Trees must not be topped during windy weather.

(4) At no time must topping, rigging up, or stripping work be done when visibility is impaired.

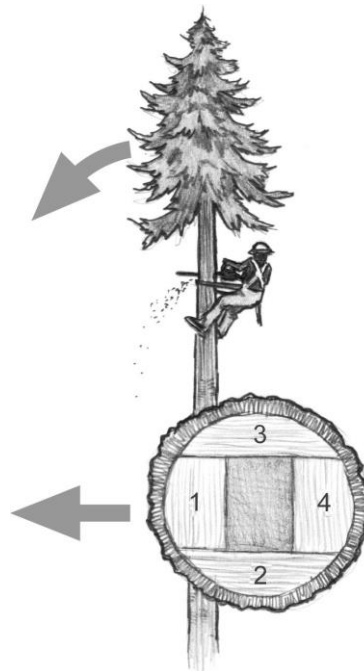

Figure 7-30 – Topping Trees

(5) Loose equipment, rigging, or material must either be removed from the tree or securely fastened.

# G

## SELECTING, PREPARING & RIGGING TREES / BLOCKS & HANGING BLOCKS

Oregon Administrative Rules  
Oregon Occupational Safety  
and Health Division

(6) Skylines with breaking strengths greater than 1-inch IPS (or equivalent) must not be hung in trees where the tree diameter at the point of attachment is less than 12 inches unless precautions are taken to prevent the tree from pinching off.

(7) A skyline must not make an angle greater than 50 degrees measured from the horizontal as it leaves the tail tree unless additional precautions are taken to prevent the tree from failing.

**Stat. Auth.:** ORS 654.025(2) and 656.726(4).  
**Stats. Implemented:** ORS 654.001 through 654.295.  
**Hist:** OR-OSHA Admin. Order 5-2003, f. 6/02/03, ef. 12/01/03.

### 437-007-0680 Blocks and Hanging Blocks.

(1) Load-bearing blocks must:

- (a) Not be used for lines other than those for which they are constructed.
- (b) Be fitted with line guards and be designed and used in a manner that prevents fouling.
- (c) Be kept in proper alignment when in use.
- (d) Have bearing and yoke pins of a material that will safely withstand the strains imposed and be securely fastened.
- (e) Have sheaves of a size designed for the size of the wire rope used.

*EXCEPTION: 437-007-0680(b) and (e) do not apply to small rig-up (Tommy Moore) blocks.*

(2) Block bearings must be kept well-lubricated.

(3) Sufficient corner or tail blocks to distribute the stress on anchors and attachments must be used on all logging systems.

(4) Tail, side, or corner blocks used in yarding must be hung in both eyes of straps or in the single eye of a strap or choker that meets the requirements OAR 437-007-0645, Tables 7-7 and 7-8.

(5) The yoke pin of haulback blocks must be inserted with the head facing the direction from which the rigging approaches, when the rigging can reach the block.

**Stat. Auth.:** ORS 654.025(2) and 656.726(4).  
**Stats. Implemented:** ORS 654.001 through 654.295.  
**Hist:** OR-OSHA Admin. Order 5-2003, f. 6/02/03, ef. 12/01/03.

## **437-007-0690 Metal Towers.**

- (1)** A competent person must direct the raising and lowering of each metal tower.
- (2)** All employees not engaged in the actual raising or lowering of metal towers must stay in the clear during these operations.
- (3)** Metal towers must be level to provide proper line spooling and avoid excessive stress on component parts.
- (4)** Each metal tower must have an identification plate permanently attached to its base or on the yarder in a position that can be easily read by a person standing on the ground or on the base platform.
- (5)** All plates must contain the following information:
  - (a)** Name and address of manufacturer and model number; and
  - (b)** The maximum and minimum inclination at which the metal tower is designed to operate.
- (6)** In addition, all identification plates on metal towers manufactured after July 1, 1980, must contain the following information:
  - (a)** The maximum breaking strength and size of mainline for which the metal tower is designed;
  - (b)** The maximum breaking strength and size of haulback line for which the metal tower is designed;
  - (c)** The number, minimum breaking strength and size of guylines or any other lines required; and
  - (d)** If the metal tower is designed for a skyline, slackline, or modified slackline system, the maximum breaking strength and size of skyline, mainline and haulback line that can be used.
- (7)** All metal towers must be operated within the manufacturer's capacity:
  - (a)** As specified on the identification plate; or
  - (b)** As modified by the manufacturer; or
  - (c)** As designed and specified by a registered professional engineer.
- (8)** If wire rope dimensionally larger in size or of a greater breaking strength than that specified by the yarder manufacturer is used for skyline, mainline, skidding line and/or haulback line, one of the following methods for limiting the load on the spar must be used:

- (a) A tamper-proof tension limiting device that automatically slacks the line loads (pull) on the metal tower to below its maximum identification plate rating.
- (b) A line fuse system installed in the skyline or mainline; or
- (c) Established operating procedures that limit line loads (pull) on the metal tower to below the maximum identification plate rating for the metal tower.
- (9) When a line fuse system is used to limit line loads (pull) on the metal tower:
- (a) The line fuse must have a designed breaking strength equal to or less than the maximum line rating of the metal tower as listed on its identification plate.
- (b) The line fuse must be certified and stamped as to the breaking strength.
- (c) The skyline or mainline must be hung in a single eye of the fuse link.
- (d) Notice must be given to crew personnel that line fuses are in use.
- (10) When operating procedures are used to limit line loads (pull) on the metal tower:
- (a) They must be observable or verifiable.
- (b) Any locking or dogging device on the brake or elsewhere must be removed or deactivated.
- (c) Personnel must be knowledgeable about the operating procedures that are in use to limit line loads.
- (11) Metal towers and their appurtenances must be inspected by a competent person each time the tower is lowered and at any time its safe condition is in doubt.
- (12) When damage from overstress or any other source is noted or suspected, the part in question must be inspected by a suitable method and found to be safe or the part repaired by a qualified person or replaced before the tower is again used.
- (13) Structural modifications or additions which affect the capacity or safe operation of metal towers must be made only under the direction of the manufacturer or a registered professional engineer. If such modifications or additions are made, the identification plate required in OAR 437-007-0690(4), (5) and (6) must reflect such changes.

**Stat. Auth.:** ORS 654.025(2) and 656.726(4).

**Stats. Implemented:** ORS 654.001 through 654.295.

**Hist:** OR-OSHA Admin. Order 5-2003, f. 6/02/03, ef. 12/01/03.  
OR-OSHA Admin. Order 3-2004, f. 6/7/04, ef. 6/7/04.

# MACHINES USED IN FOREST ACTIVITIES

# H

## TABLE OF CONTENTS

<b>437-007-0700</b>	General Work Practices .....	H-1
<b>437-007-0705</b>	General Machine Operator Requirements .....	H-1
<b>437-007-0710</b>	General Machine Requirements .....	H-3
<b>437-007-0715</b>	Attaching and Spooling Line (wire or synthetic rope) .....	H-4
<b>437-007-0720</b>	Fairleads .....	H-6
<b>437-007-0725</b>	Securing Machines .....	H-6
<b>437-007-0730</b>	Loading Machines .....	H-7
<b>437-007-0735</b>	Chippers .....	H-7
<b>437-007-0740</b>	Machine Exhaust Systems .....	H-7
<b>437-007-0745</b>	Windows and Windshields on Machines .....	H-8
<b>437-007-0750</b>	Drum Brakes.....	H-8
<b>437-007-0755</b>	Machine Travel Brakes.....	H-8
<b>437-007-0760</b>	Outriggers .....	H-9
<b>437-007-0765</b>	Hauling or Moving Machines.....	H-9
<b>437-007-0770</b>	Protective Structures for Operators, General Requirements .....	H-10
<b>437-007-0775</b>	Protective Structures for Operators, Machines Manufactured On Or After July 1, 2004.....	H-13
<b>437-007-0780</b>	Protective Structures for Operators, Machines Used On Or After July 1, 2014.....	H-17

**H**

Oregon Administrative Rules  
Oregon Occupational Safety  
and Health Division

# GENERAL WORK PRACTICES / GENERAL MACHINE OPERATOR REQUIREMENTS

# H

## **437-007-0700 General Work Practices.**

(1) Machines must be operated a sufficient distance from personnel and other machines to not create a hazard for any person.

(2) An unimpaired horizontal clearance of not less than 3 feet must be maintained between the rotating superstructure of any machine and any adjacent object or surface. If this clearance cannot be maintained, personnel must be warned of the pinch point area. Measures taken to warn personnel of the pinch point area may consist of a warning line constructed of rope or ribbon supported on stanchions, barriers, cones, flags, etc.

(3) Items of personal property, tools or other miscellaneous materials must not be stored on or within 3 feet of any machine if such items would expose personnel to hazards caused by the rotation of the machine's superstructure.

**EXCEPTION:** These items may be stored within 3 feet when in a locked box or otherwise secured and under the exclusive control of the equipment operator.

(4) Personnel must not approach to within 3 feet of a machine when a hazardous area is created by the rotation of the machine's superstructure without:

(a) Informing the operator of their intent.

(b) Receiving acknowledgment from the operator that the operator understands their intention.

(c) Stopping the machine while personnel are in the hazardous area.

(5) No person, other than the operator, may ride on a machine unless seating, seat belts and other protection equivalent to that provided for the operator are provided.

(6) Operators must not permit workers to ride on arches, reaches or turns of logs.

**Stat. Auth.:** ORS 654.025(2) and 656.726(4).

**Stats. Implemented:** ORS 654.001 through 654.295.

**Hist:** OR-OSHA Admin. Order 5-2003, f. 6/02/03, ef. 12/01/03.

## **437-007-0705 General Machine Operator Requirements.**

(1) Machines must be started and operated only by authorized personnel.

(2) Operators must be instructed about and comply with the manufacturer's recommendations for machine operation, maintenance, safe work practices, and site operating procedures.

(3) Before starting or moving any machine, the operator must determine that personnel are in the clear.

# H

## GENERAL MACHINE OPERATOR REQUIREMENTS

Oregon Administrative Rules  
Oregon Occupational Safety  
and Health Division

- (4) Operators must inspect their machines each day before starting work.
- (5) All machine engines must be off during inspection or repair except where necessary for adjustment or checking fluids.
- (6) Machines must not be operated with defective steering, braking, other parts or components that are necessary for safe operation.
- (7) Defective hydraulic hoses, lines and fittings that affect the safe operation of the machine must be immediately replaced.
- (8) All repairs and adjustments necessary for safe operation must be made before any strain or load is placed upon any machine.
- (9) Machines must not be operated until all guards are reinstalled, safety devices reactivated, and maintenance equipment removed after adjustments or repairs are made.
- (10) Operators must start and operate machines only from the operator's station or from a safe area recommended by the manufacturer.
- (11) At the start of each shift, machine operators must test all drum brakes before taking a load.
- (12) Machines must be operated within their stability limits.
- (13) Loads on forklift-type log handling machines must be transported:
  - (a) As low as safely possible.
  - (b) In a manner that minimizes obstructing the operator's view.
- (14) The machine operator must apply the parking brake, brake locks or other equivalent means to hold the machine stationary before dismounting.
- (15) Blades must be lowered to the ground or other stable surfaces while the operator is out of the normal operating work station.
- (16) Grapples, delimeter masts, feller buncher attachments, forks and other similar devices must be stable and pose no hazard to others while the operator is out of the normal operating work station.
- (17) If a hydraulic or pneumatic storage device can move machine elements, such as, but not limited to, blades, buckets, saws and shears, after the machine is shut down, the pressure or stored energy from the element must be discharged as specified by the manufacturer.

**Stat. Auth.:** ORS 654.025(2) and 656.726(4).

**Stats. Implemented:** ORS 654.001 through 654.295.

**Hist:** OR-OSHA Admin. Order 5-2003, f. 6/02/03, ef. 12/01/03.

# GENERAL MACHINE REQUIREMENTS

# H

## **437-007-0710 General Machine Requirements.**

- (1) Machine seats must be securely attached.
  - (2) Operating foot controls must be constructed of or covered with a non-slip material suitable for the footwear worn.
  - (3) Machine decks, drums and other surfaces where workers walk or stand must be constructed of or covered with a non-slip material suitable for the footwear worn.
  - (4) Catwalks or platforms must be provided on machines where personnel perform routine operation, maintenance or rigging work.
  - (5) A safe and adequate means of access and egress such as, steps, ladders, handholds and railings must be provided and maintained to all parts of vehicles and machines where employees must go. Machine access must comply with the Society of Automotive Engineers' (SAE)-J185-1988 or ISO 2867:1994, Access Systems for Off-Road Machines.
- NOTE:** See the mandatory requirements in Appendix 7-D for accessing metal towers.
- (6) Guards must be provided on machines to protect employees from flying chunks, logs, chips, bark, limbs and other material.
  - (7) Guards must be in place at all times when machines are in use.
  - (8) All exposed moving parts, such as shafts, pulleys, belts, conveyers and gears on machinery and equipment must be guarded in accordance with OAR 437, Division 2, Subdivision O, Machinery and Machine Guarding.
  - (9) Hydraulic hose, tubing or fittings must be arranged to eliminate abrasive contacts.
  - (10) Machines must be free of excess flammable and combustible material that may create a fire.
  - (11) Machine sleds, bases or frames must be strong enough to withstand any imposed stresses.
  - (12) Machines and their components must be securely anchored or otherwise stabilized to prevent unintended movement during operation.
- EXCEPTION:** This does not apply to tractors or skidders.
- (13) A limit switch must be installed on electric-powered log loaders to limit lift arms travel in the event the control switch is not released in time.
  - (14) When forklift type machines are used to load, unload or handle trailers, a positive means of holding the lifting attachment on the fork must be installed and used.

# GENERAL MACHINE REQUIREMENTS / ATTACHING & SPOOLING LINE

(15) Guyline drum controls and outrigger controls must be separated and clearly identified to prevent engaging the wrong control.

(16) Boom-type machines must have a boom stop to prevent over-topping of the boom.

**Stat. Auth.:** ORS 654.025(2) and 656.726(4).

**Stats. Implemented:** ORS 654.001 through 654.295.

**Hist:** OR-OSHA Admin. Order 5-2003, f. 6/02/03, ef. 12/01/03.

## 437-007-0715 Attaching and Spooling Line (wire or synthetic rope).

(1) Ends of lines attached to drums on machines must be secured by end attachments that develop the ultimate strength of the line unless three wraps of line are maintained on the drum at all times.

**NOTE:** This does not apply to tractors or skidders.

(2) Winch lines on tractors or skidders must be attached to the drums with a breakaway device.

(3) Wire rope must be wound on drum spools in a manner to prevent excessive wear, kinking, chafing, or fouling.

(4) A guide pulley, tool, stick, iron bar, or other manual or mechanical means must be used when guiding lines onto drums.

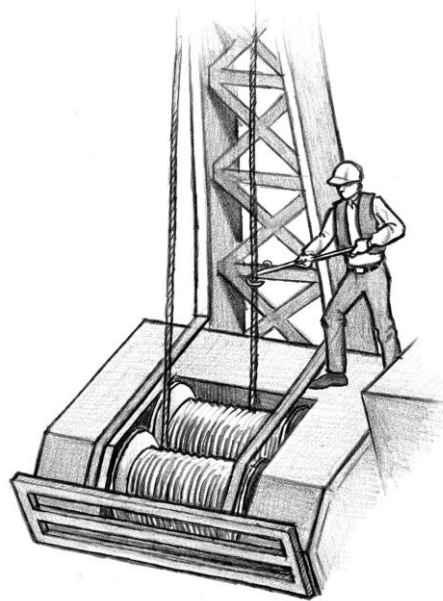
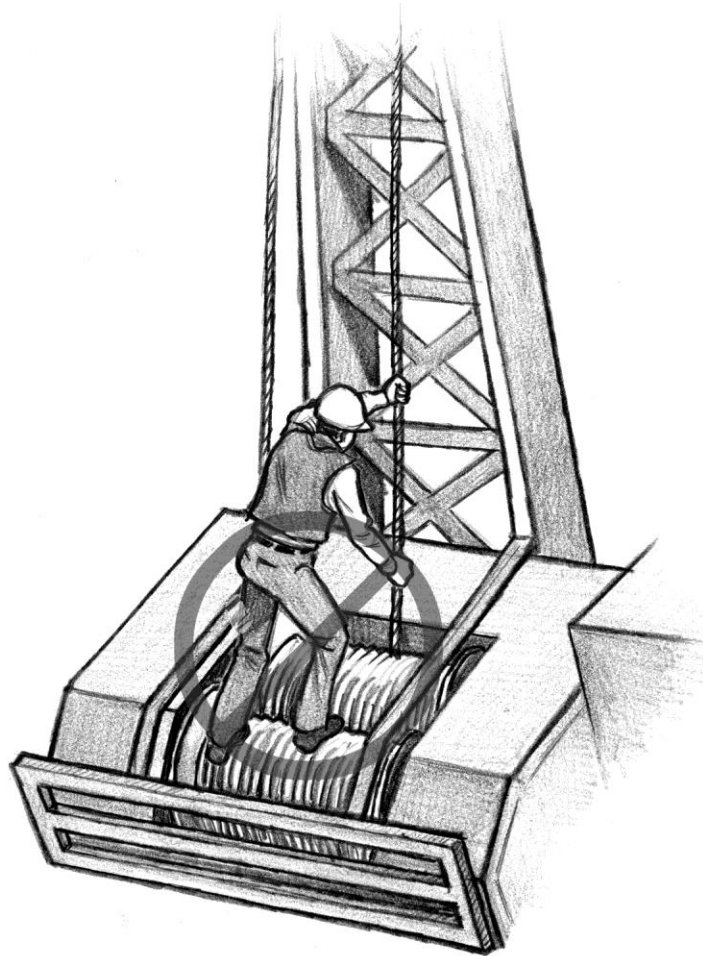

Figure 7-31 – Spooling Lines – Least Risky

(5) Personnel must never allow line to slide through their gloved hands or place any part of their body in direct contact with the line.



**Figure 7-32 – Spooling Lines – Risky**

(6) When it is necessary for personnel to stand on a drum to spool line or perform machine maintenance, precautions must be taken to prevent unintentional activation of the drum.

(7) Personnel must not stand on a bare drum or lines spooled on a drum when wearing caulk boots unless a non-slip material covers the standing surface.

**Stat. Auth.:** ORS 654.025(2) and 656.726(4).

**Stats. Implemented:** ORS 654.001 through 654.295.

**Hist:** OR-OSHA Admin. Order 5-2003, f. 6/02/03, ef. 12/01/03.

**437-007-0720 Fairleads.**

- (1) Properly align fairleads at all times.
- (2) Fairleads must be of a design that will prevent line damage.

**Stat. Auth.:** ORS 654.025(2) and 656.726(4).  
**Stats. Implemented:** ORS 654.001 through 654.295.  
**Hist:** OR-OSHA Admin. Order 5-2003, f. 6/02/03, ef. 12/01/03.

**437-007-0725 Securing Machines.**

- (1) Before the operator leaves the operator's work station, procedures must be implemented to prevent the release of stored energy, accidental start up, or movement of the machine.
- (2) The employer must instruct all authorized employees how to use shut down procedures.
- (3) Authorized employees must demonstrate a working knowledge of the specific shut down procedures they are required to use.
- (4) Locks, tags and other devices used to control hazardous energy must be durable.
- (5) The words "DO NOT START," "DO NOT OPERATE," or other appropriate warning must be displayed on tags used to control energy.
- (6) Tags used to control hazardous energy must be placed so they are obvious to anyone attempting to operate the machinery.
- (7) Blades must be lowered to the ground or other stable surfaces to secure the blade and machine from movement while maintenance or repair activities are performed.
- (8) Grapples, delimeter masts, feller buncher attachments, forks and other similar devices must be stable and not pose a hazard to personnel while maintenance or repair activities are performed.
- (9) If a hydraulic or pneumatic storage device can move machine elements, such as blades, buckets, saws, shears, etc., after the machine is shut down for maintenance or repair, the pressure or stored energy that can activate the movable elements must be discharged.
- (10) Before locks, tags and other devices that are used to control hazardous energy are removed and machinery or equipment is started, the work area must be inspected to ensure that:
  - (a) All tools have been removed.

# SECURING MACHINES / LOADING MACHINES / CHIPPERS / MACHINE EXHAUST SYSTEMS

# H

(b) Personnel are in the clear.

(11) Guards must be replaced after necessary adjustments are made.

(12) Machines or equipment that are not mounted on sleds, wheels, or tracks must comply with the requirements of Division 2/J, §1910.147, for controlling hazardous energy.

**Stat. Auth.:** ORS 654.025(2) and 656.726(4).  
**Stats. Implemented:** ORS 654.001 through 654.295.  
**Hist:** OR-OSHA Admin. Order 5-2003, f. 6/02/03, ef. 12/01/03.

## 437-007-0730 Loading Machines.

(1) Grapple arms or other positive means of keeping logs on the forks must be used on forklift type log handling and loading machines.

(2) Log loading machines must be equipped with an audible signaling device of a different tone than other signaling devices in the area.

**Stat. Auth.:** ORS 654.025(2) and 656.726(4).  
**Stats. Implemented:** ORS 654.001 through 654.295.  
**Hist:** OR-OSHA Admin. Order 5-2003, f. 6/02/03, ef. 12/01/03.

## 437-007-0735 Chippers.

(1) Access covers and doors to chippers must remain closed until the drum or disk is at a complete stop.

(2) Infeed and discharge ports on chippers must prevent contact with discs, knives, or blower blades.

**Stat. Auth.:** ORS 654.025(2) and 656.726(4).  
**Stats. Implemented:** ORS 654.001 through 654.295.  
**Hist:** OR-OSHA Admin. Order 5-2003, f. 6/02/03, ef. 12/01/03.

## 437-007-0740 Machine Exhaust Systems.

(1) Machines must have an exhaust system maintained in good working order.

(2) Machines must be equipped with a muffler of the type recommended by the machine manufacturer.

(3) Exhaust pipes must direct the exhaust gases away from the operator.

(4) Exhaust pipes must be insulated or located to protect employees from accidental contact with the pipes and must permit spark arrester clean out.

**Stat. Auth.:** ORS 654.025(2) and 656.726(4).  
**Stats. Implemented:** ORS 654.001 through 654.295.  
**Hist:** OR-OSHA Admin. Order 5-2003, f. 6/02/03, ef. 12/01/03.

# H

## WINDOWS & WINDSHIELDS ON MACHINES / DRUM BRAKES / MACHINE TRAVEL BRAKES

Oregon Administrative Rules  
Oregon Occupational Safety  
and Health Division

### 437-007-0745 Windows and Windshields on Machines.

(1) Windows and windshields must:

- (a) Be free of deposits or defects that could endanger the operator or other personnel.
- (b) Be safety glass or a type of material that provides equal protection.
- (c) Not impair the vision of the operator.
- (d) Have an additional metal screen or guard where windows and windshields do not provide adequate operator protection.

**Stat. Auth.:** ORS 654.025(2) and 656.726(4).

**Stats. Implemented:** ORS 654.001 through 654.295.

**Hist:** OR-OSHA Admin. Order 5-2003, f. 6/02/03, ef. 12/01/03.

### 437-007-0750 Drum Brakes.

- (1) Brakes or dogs must be installed on all machine drums and maintained in effective working condition.
- (2) Machine drum brakes must have an independent locking device that will hold the drum when the operator leaves the machine and the machine is not operating.
- (3) Machine drum brakes must be protected from direct exposure to the elements or must be of a design or construction which will render them impervious to such exposure.

**Stat. Auth.:** ORS 654.025(2) and 656.726(4).

**Stats. Implemented:** ORS 654.001 through 654.295.

**Hist:** OR-OSHA Admin. Order 5-2003, f. 6/02/03, ef. 12/01/03.

### 437-007-0755 Machine Travel Brakes.

(1) Self-propelled machines built on or after July 1, 1985, must have braking systems as follows:

- (a) A service braking system that is the primary means of stopping and holding the equipment.
- (b) An emergency stopping system that is a secondary means of stopping the equipment in the event of any single failure of the service system.
- (c) A parking brake system that will continuously hold a stopped machine stationary within the limits of traction so the operator may leave the vehicle without the vehicle moving, and to prevent movement of the vehicle while unattended.

# MACHINE TRAVEL BRAKES / OUTRIGGERS / HAULING OR MOVING MACHINES

# H

**(2)** The braking systems in this section (OAR 437-007-0755) must comply with Society of Automotive Engineers' (SAE) or International Organization for Standards (ISO) Recommended Practices:

**(a)** ISO 11512 MAR95 – Braking Performance – In-Service Crawler Tractors and Crawler Loaders.

**(b)** J/ISO 3450 JAN98 – Earthmoving Machinery – Braking Systems of Rubber-Tired Machines – Systems and Performance Requirements and Test Procedures.

**(c)** J/ISO 11169 FEB99 – Machinery for Forestry – Wheeled Special Machines – Vocabulary, Performance Test Methods, and Criteria for Brake Systems.

**(3)** Self-propelled logging machines manufactured prior to July 1, 1985, must have braking systems installed, tested and maintained in as effective a condition as originally installed by the manufacturer.

**Stat. Auth.:** ORS 654.025(2) and 656.726(4).

**Stats. Implemented:** ORS 654.001 through 654.295.

**Hist:** OR-OSHA Admin. Order 5-2003, f. 6/02/03, ef. 12/01/03.

## **437-007-0760 Outriggers.**

**(1)** All outriggers must be placed on a stable base or cribbing.

**(2)** Hydraulic outriggers must have a positive holding device (velocity fuse, load check valve, manually operated valve, or equivalent) to prevent movement of the piston in the event of a hose, hose fitting or other failure in the hydraulic system.

**Stat. Auth.:** ORS 654.025(2) and 656.726(4).

**Stats. Implemented:** ORS 654.001 through 654.295.

**Hist:** OR-OSHA Admin. Order 5-2003, f. 6/02/03, ef. 12/01/03.

## **437-007-0765 Hauling or Moving Machines.**

**(1)** The weight of any machine being hauled must not exceed the designed capacity of the transporting vehicle.

**(2)** Machines must be loaded, secured and unloaded so they do not create a hazard for personnel.

**(3)** Machines must not be moved or operated until all personnel are in the clear.

**(4)** A signal person must guide operators who do not have a clear and unobstructed view of the direction of travel and the surface being traveled.

# H

## HAULING OR MOVING MACHINES / PROTECTIVE STRUCTURES FOR OPERATORS, GENERAL REQUIREMENTS

Oregon Administrative Rules  
Oregon Occupational Safety  
and Health Division

(5) When an operator does not have a clear and unobstructed view of the direction of travel, an audible alarm or horn must be sounded before the machine, equipment or vehicle is moved.

(6) Track-mounted machines with manual transmissions must be equipped with a ratchet or other device which will prevent unintended disengagement or reversing of the machine, and the operator must be informed of the proper technique.

(7) When moving machines equipped with metal towers, the tower must be lowered. When needed for mobility, the tower may be raised provided that it is adequately supported so that the stability of the machine is not impaired during movement.

**Stat. Auth.:** ORS 654.025(2) and 656.726(4).

**Stats. Implemented:** ORS 654.001 through 654.295.

**Hist:** OR-OSHA Admin. Order 5-2003, f. 6/02/03, ef. 12/01/03.

### 437-007-0770 Protective Structures for Operators, General Requirements.

(1) Cabs and protective structures for machine operators must be:

(a) Provided when machine use exposes an operator to hazardous conditions.

(b) Sufficient in strength and dimension to withstand the impact of materials handled.

(2) Operator controlled skidding machines manufactured after April 1, 1992, must have adequate operator protection of 1/4-inch woven wire mesh with openings no greater than 2 inches in size or other materials providing equivalent or greater protection.

(3) Every tractor, skidder, front-end loader (other than high mast forklifts), scraper, grader and dozer manufactured on or after July 1, 1969, must be equipped with Roll-Over Protective Structures (ROPS) installed, tested and maintained in accordance with Division 2/N, OAR 437-002-0223, as amended through January 30, 2003.

**EXCEPTION:** This rule does not apply to log stackers used exclusively to lift, transport or stack logs in sorting yards or transfer stations.

(4) Every tractor, skidder, front-end loader (other than high mast forklifts), scraper, grader and dozer manufactured on or after July 1, 1980, must be equipped with ROPS meeting the Society of Automotive Engineers' SAE 1040 April 1980, Performance Criteria for Roll-Over Protective Structures (ROPS) for Construction, Earthmoving, Forestry and Mining Machines.

**EXCEPTION:** This rule does not apply to log stackers used exclusively to lift, transport or stack logs in sorting yards or transfer stations.

## PROTECTIVE STRUCTURES FOR OPERATORS, GENERAL REQUIREMENTS

# H

(5) Every tractor, skidder, front-end loader, scraper, grader and dozer manufactured on or after July 1, 1980, must be equipped with a falling object protective structure (FOPS) for overhead protection installed, tested and maintained in accordance with the Society of Automotive Engineers' SAE J231-1981, Minimum Performance Criteria for Falling Object Protective Structures (FOPS).

(6) Machines equipped with ROPS or FOPS as required in OAR 437-007-0770(3), (4) and (5) must comply with the Society of Automotive Engineers' SAE J397April-1988, Deflection Limiting Volume (DLV) for Laboratory Evaluation of Roll-Over Protective Structures (ROPS), and Falling Object Protective Structures (FOPS) for Construction and Industrial Vehicles.

(7) The ROPS structure must have a shear or deflecting guard extending from the leading edge of the forward arch to the front part of the tractor frame. If longitudinal arches are used, they must extend from the rear of the tractor to the front frame of the tractor with each arch having an intermediate support located approximately at the dash so that operator access or egress is not impeded.

**EXCEPTION:** This rule does not apply to rubber-tired loaders, scrapers and graders.

(8) The opening in the rear of the ROPS structure must be covered with 1/4-inch woven wire having not less than 1 1/2-inch or more than 2-inch openings, or other material providing equivalent or greater protection. Affix this covering to the structural members so that ample clearance is provided between the screen and the back of the operator.

(9) ROPS structures must have side screens of the same strength as the back screen or vertical barrier bars spaced at intervals not greater than 6 inches on center and constructed of not less than 1-inch double strength pipe installed on all logging machines equipped with ROPS in addition to the back screen.

(10) Side barriers must extend forward to the front edge of the operator's seat or as far forward as possible from the rear corners of the canopy sides to a structural member behind the front edge of the seat.

(11) Protective structures must be of sufficient height and width so they:

(a) Do not impair the movement of the operator or prevent immediate escape from the machine in emergencies.

(b) Allow the operator as much visibility as possible.

(12) Clearance between the deck and the protective structures of the machines at points of egress must not be less than 52 inches.

(13) There must be a second means of egress from all logging machines.

(14) Structural members of the ROPS must have smooth, rounded edges and coverings free from projections which could puncture or tear flesh or clothing.

# H

## PROTECTIVE STRUCTURES FOR OPERATORS, GENERAL REQUIREMENTS

Oregon Administrative Rules  
Oregon Occupational Safety  
and Health Division

**(15)** Rollover protective systems must be maintained in a manner that will preserve their original strength. Welding may only be performed by qualified welders.

**(16)** Certified roll-over protective structures must be identified by a metal tag:

**(a)** Permanently attached to the ROPS in a position where it can be easily read.

**(b)** Permanently and clearly stamped, etched or embossed with the:

**(A)** Name and address of the certifying manufacturer or registered professional engineer.

**(B)** ROPS model number (if any).

**(C)** Vehicle make, model or series number that the ROPS is designed to fit.

**(D)** Maximum weight of the machine for which the structure is certified.

**(E)** SAE tag criteria number.

**(17)** Tractors and skidders manufactured prior to 1969 that cannot be fitted with complete ROPS may be used for cleaning debris off landings, snubbing vehicles and machines or as an anchor, provided no clearing, road construction or yarding is performed off a road or landing surface.

**(18)** Seat belts must be provided and used on all machines with ROPS/FOPS and have quick release buckles designed to minimize the possibility of accidental release.

**(19)** Seat belts must be maintained in an effective condition and comply with SAE Standard J386-1985.

**Stat. Auth.:** ORS 654.025(2) and 656.726(4).

**Stats. Implemented:** ORS 654.001 through 654.295.

**Hist:** OR-OSHA Admin. Order 5-2003, f. 6/02/03, ef. 12/01/03.

**PROTECTIVE STRUCTURES FOR  
OPERATORS, MACHINES MANUFACTURED  
ON OR AFTER JULY 1, 2004**

**H**

**437-007-0775 Protective Structures For Operators, Machines Manufactured On Or After July 1, 2004.**

**NOTE:** The scope of coverage in the SAE and ISO standards referenced in OAR 437-007-0775(11) and (14) are not intended to exclude any machines included in the scope of this Division.

**(1)** Machines manufactured on or after July 1, 2004, that permit the operator to stand on the ground adjacent to the machine while operating the machine:

**(a)** Are not required to have a fully enclosed cab.

**(b)** Must have overhead and landing chute side protection meeting the requirements of SAE J1084 April 80.

**(2)** Cabs and protective structures on forest activities machines manufactured on or after July 1, 2004, must have smooth, rounded edges and coverings free from projections which could puncture or tear flesh and clothing.

**(3)** Any machine operator cab, protective structure or attached guarding manufactured on or after July 1, 2004, that is damaged or weakened, to a strength less than that required by certified performance criteria must be replaced or immediately repaired.

**(4)** Repairs or modifications to major structural members of any operator cab, protective structure or attached guarding on machines manufactured on or after July 1, 2004, certified to performance criteria, must comply with the specific instructions of the original equipment manufacturer or be certified by a professional engineer.

**(5)** An operator restraint system must be provided and used on all machines manufactured on or after July 1, 2004, and equipped with ROPS, FOPS, reinforced cabs or overhead guards. The operator restraint system must:

**(a)** Comply with SAE J386 NOV97 or ISO 6683 Amended 1:1990.

**(b)** Be maintained in an effective condition.

***EXCEPTION:** Use of the operator restraint system is not required when operating yarders that are stationary.*

**(6)** The level of protection provided by any machine operator cab, protective structure or attached guarding manufactured on or after July 1, 2004, must be identified by a label. The label must:

**(a)** Comply with the labeling requirements of ISO 3471:1994 or ISO 12117:1997 as applicable.

# H

## PROTECTIVE STRUCTURES FOR OPERATORS, MACHINES MANUFACTURED ON OR AFTER JULY 1, 2004

Oregon Administrative Rules  
Oregon Occupational Safety  
and Health Division

(b) Not claim that exclusion from a standard is equivalent to compliance with that standard.

*NOTE: Machines capable of 360-degree upper structure rotation are excluded from the SAE J1040 MAY94 and ISO 8082:1994 standards for ROPS. In this case, the exclusion from these standards does not allow the label on a machine capable of 360-degree upper structure rotation to state compliance with SAE J1040 MAY94 or ISO 8082:1994.*

(7) Each machine used in forest activities that is manufactured on or after July 1, 2004, must have a fully enclosed cab for the operator which prevents objects from entering the cab. The fully enclosed cab must have:

(a) The upper portion enclosed with materials that allow for maximum visibility and meets the Operator Protective Structure (OPS) requirements of SAE J1084 APR80 or ISO 8084:1993.

(b) Transparent material must not have defects, such as, but not limited to, scratches, cracks, or broken safety glass which could create a hazard for the operator.

(c) The lower portion enclosed with solid material meeting the requirements of SAE J1084: APR80 or ISO 8084:1993.

(d) The overhead covering enclosed with solid material meeting the FOPS requirements of ISO 8083:1989 (11,600 Joules).

*EXCEPTION 1: 437-007-0775(7)(a) is not required for the front window in machines operating in sort yards, on landings and similar prepared surfaces which are equipped with front guards meeting the SAE J1356 FEB88 requirements.*

*EXCEPTION 2: 437-007-0775(7)(a) and (7)(c) are not required on machines operating in mill yards.*

(8) The machine operator space in cabs and protective structures manufactured on or after July 1, 2004, must comply with ISO 3411:1995.

(9) Access to machine operator cabs and protective structures manufactured on or after July 1, 2004, must comply with SAE J185-1988 or ISO 2867:1994.

(10) Each fully enclosed cab installed on machines manufactured on or after July 1, 2004, must have a second means of egress which can be opened from both the inside and outside without tools.

(11) Machines capable of handling material in front of or above the deflection limiting volume (DLV), as defined by SAE J397 APR98, including yarders with cabs mounted next to the tower (boom), manufactured on or after July 1, 2004, must have a front and top guard meeting the requirements of SAE J1356:FEB88.

**EXCEPTION:** The rule does not apply to rubber-tired or tracked front-end loaders when equipped with buckets or forks with hold down grapple arm(s).

**PROTECTIVE STRUCTURES FOR  
OPERATORS, MACHINES MANUFACTURED  
ON OR AFTER JULY 1, 2004**

**H**

**(12)** Machines used for forest activities and those identified by SAE J1116 MAR99 that are manufactured on or after July 1, 2004, must:

**(a)** Be equipped with ROPS which meet the criteria in SAE J1040-1994 or ISO 8082:1994.

**(b)** Comply with the requirements of OAR 437-007-0775(2) through (11).

*EXCEPTION 1: This rule does not apply to high mast log stackers used exclusively to lift, transport or stack logs in sorting yards or transfer stations.*

*EXCEPTION 2: This rule does not apply to machines capable of 360-degree upper structure rotation that are excluded from SAE J1040:May 94 and ISO 8082:1994 standards for ROPS.*

**(13)** Shear or deflector guarding must be:

**(a)** Installed in front of each cab to deflect whipping saplings and branches.

**(b)** Located so they do not impede visibility and access to the cab.

*EXCEPTION: This rule does not apply to rubber-tired loaders, scrapers and graders.*

**(14)** Machines used for forest activities manufactured on or after July 1, 2004, that are excluded from the ROPS, SAE J1040:1994 or ISO 8082:1994 requirements because they are capable of 360 degree upper structure rotation must be equipped with fully enclosed cabs that meet the requirements of 437-007-0775(2) through (11). These machines must be limited to use on surfaces that are prepared, excavated or constructed of solid material with a slope of less than 20 percent unless the operator's cab is equipped with the following additional protection:

**(a)** A Tip Over Protective Structure (TOPS) that meets the requirements of ISO 12117 1997:(E) with the exception of the "Formulae for the determination of energy required" in section 6.1.4 Table 1. The "Formulae for the determination of energy required" in Table 1 is changed as follows:

**(A)** The lateral energy equation is replaced with  $7300(M/10,000)^{0.9}$  or 20,000 Joules, whichever is greater where M is the machine mass in kilograms.

**(B)** The longitudinal energy equation is replaced with  $4300(M/10,000)^{0.9}$  or 12,000 Joules, whichever is greater where M is the machine mass in kilograms.

**(b)** An "Off-Boom Side Cab Guard" that complies with the "Front Guard" requirements of SAE J1356: FEB88.

**(c)** An "Off-Boom Side Cab Guard" that complies with 437-007-0775(14)(b) when the following modifications are made to SAE J1356:FEB88:

# H

## PROTECTIVE STRUCTURES FOR OPERATORS, MACHINES MANUFACTURED ON OR AFTER JULY 1, 2004

Oregon Administrative Rules  
Oregon Occupational Safety  
and Health Division

**(A)** Section 3.2. Each occurrence of the term “Front Guard” in this section is replaced with “Off Boom Side Cab Guard.”

**(B)** Section 3.2.4.1. The term “front of the DLV” on line 3 is replaced with “off boom side of the DLV.”

**(C)** Section 5.2. Each occurrence of the term “Front Guard” in this section is replaced with “Off Boom Side Cab Guard.”

**(D)** Section 5.2.3. The term “front of the DLV” on line 2 is replaced with “off boom side of the DLV.”

**(E)** Section 6.2. The term “Front Guard” on line 1 is replaced with “Off Boom Side Cab Guard.”

**(15)** Machines used for road construction activities on prepared surfaces with a slope of less than 20 percent are not required to have front and/or top cab protective structures when the machine’s activities do not expose operators to the hazards of yarding, loading or timber falling.

**Stat. Auth.:** ORS 654.025(2) and 656.726(4).

**Stats. Implemented:** ORS 654.001 through 654.295.

**Hist:** OR-OSHA Admin. Order 5-2003, f. 6/02/03, ef. 12/01/03.  
OR-OSHA Admin. Order 2-2008, f. 3/5/08, ef. 3/5/08.

## PROTECTIVE STRUCTURES FOR OPERATORS, MACHINES USED ON OR AFTER JULY 1, 2014

# H

**437-007-0780 Protective Structures for Operators, Machines Used On Or After July 1, 2014.** Each machine used in forest activities on or after July 1, 2014, that is excluded from the ROPS, SAE J1040 MAY94 or ISO 8082:1994 requirements, because it is capable of 360 degree upper structure rotation, must:

- (1) Meet the same requirements as those machines manufactured on or after July 1, 2004, or
- (2) Be limited to use on surfaces that are prepared, excavated or constructed of solid materials with a slope of less than 20 percent when handling logs or other materials, or
- (3) Have a clear path of travel and be limited to slopes of 40 percent or less when used only as anchors for cable yarding systems.

**EXCEPTION:** 437-007-0780 does not apply to machines manufactured before July 1, 2004 that are equipped and maintained with a front and top guard structure meeting the performance criteria of SAE J1356:FEB88 or ISO 10262:1998 Level II.

**Stat. Auth.:** ORS 654.025(2) and 656.726(4).

**Stats. Implemented:** ORS 654.001 through 654.295.

**Hist:** OR-OSHA Admin. Order 5-2003, f. 6/02/03, ef. 12/01/03.

OR-OSHA Admin. Order 2-2008, f. 3/5/08, ef. 3/5/08.

OR-OSHA Admin. Order 2-2014, f. 5/29/14, ef. 5/29/14.

**H**

Oregon Administrative Rules  
Oregon Occupational Safety  
and Health Division

**TABLE OF CONTENTS**

<b>437-007-0800</b>	General Requirements .....	I-1
<b>437-007-0805</b>	Mechanical Falling.....	I-3
<b>437-007-0810</b>	Manual Falling .....	I-4
<b>437-007-0815</b>	Wedges .....	I-7
<b>437-007-0820</b>	Bucking Trees/Logs.....	I-7
<b>437-007-0825</b>	Tree Jacking .....	I-8
<b>437-007-0830</b>	Tree Pulling .....	I-9

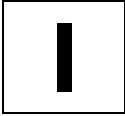

## 437-007-0800 General Requirements.

(1) Any worker falling a tree or bucking a log must be located so their work will not endanger others.

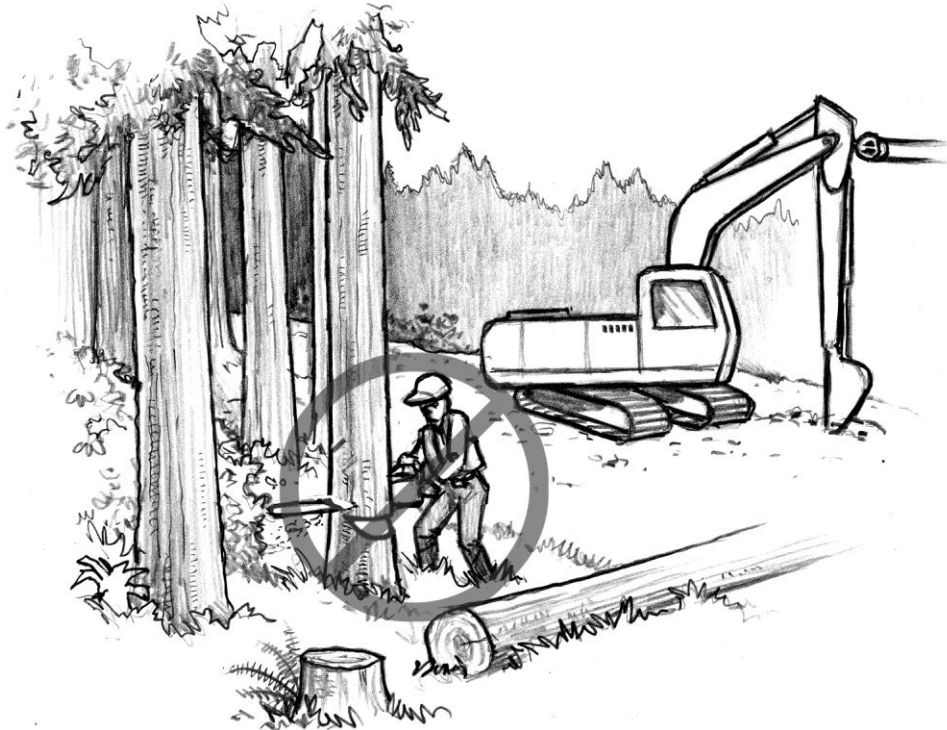
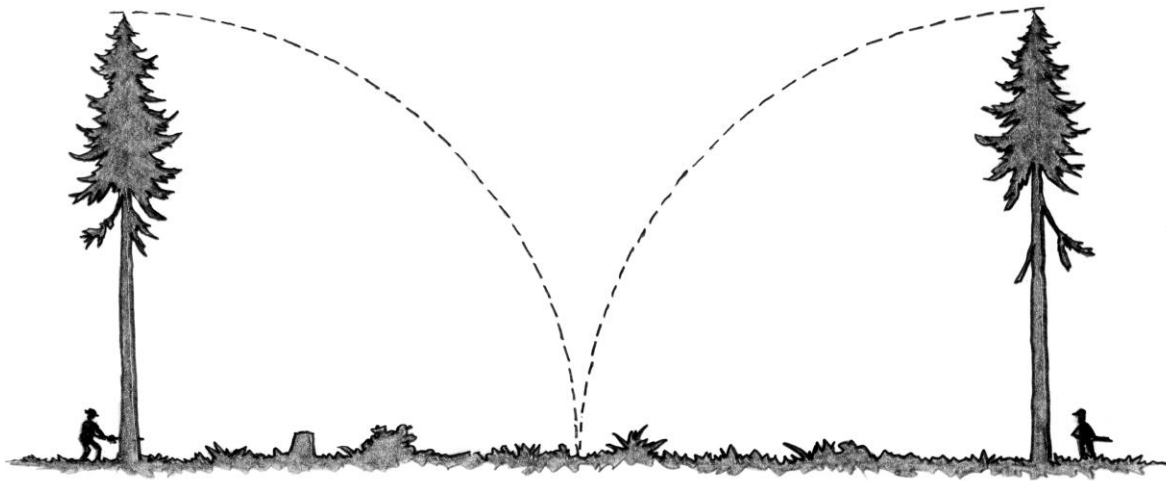

**Figure 7-33 – Falling – Too Close**

(2) Personnel must not approach within two tree lengths of a tree being felled without receiving a signal from the person falling the tree that it is safe to approach.

(3) The minimum distance between any worker(s) manually falling trees and any other personnel must be twice the height of the trees being felled.

**EXCEPTION:** This does not apply to a team of two or more working on the same tree.



**Figure 7-34 – Falling – Two Tree Lengths**

**(4)** Workers who are single jacking must be positioned so they are close enough to render assistance to each other in case of an emergency. They must be:

- (a)** Within sight of each other, or
- (b)** Able to talk to each other by natural unassisted voice communication.

**(5)** Workers who are single jacking must work in compliance with 437-007-0215, Working Alone, and 437-007-0220, Medical Service and First Aid requirements.

**(6)** Workers whose primary job is to manually operate a chain saw for activities such as, falling and bucking trees, pre-commercial thinning, brush clearing and slashing must carry a shrill sounding whistle, such as a police whistle. The whistle must be used only to summon help in case of an emergency.

**NOTE:** This does not include chasers on active landings.

**(7)** Workers must not fall or buck trees within a unit of standing timber prior to any cutting operation if such falling or bucking creates a hazardous condition for subsequent cutters or operations.

**(8)** When hazardous conditions are created from tree cutting operation(s) next to roads, the requirements of OAR 437-007-0510 and 0515 apply.

# GENERAL REQUIREMENTS / MECHANICAL FALLING



- (9) OAR 437-007-0230 applies when a tree could fall within 15 feet of a power line.
- (10) An inexperienced worker must not fall trees or buck logs unless they are working under the direct supervision of a qualified person.
- (11) When a worker is not sure how to safely fall or buck a tree, the tree must not be cut until the:
- (a) Worker confers with a supervisor or qualified person.
  - (b) Safest possible work method or procedure is identified to complete the job.
- (12) Workers must check for overhead hazards while falling, bucking or limbing trees.
- (13) Workers must not fall and buck trees when their vision is impaired by weather or darkness.
- (14) Spring poles and limbs under stress must be cut in a way that releases the tension and other personnel must be in the clear as the cut is being completed.
- (15) Workers must not operate a chain saw:
- (a) To cut directly overhead in a manner that would cause limbs, chunks of bark, or pieces of wood to fall on the operator.
  - (b) At a distance that would require them to lose a safe grip on the saw.

**Stat. Auth.:** ORS 654.025(2) and 656.726(4).  
**Stats. Implemented:** ORS 654.001 through 654.295.  
**Hist:** OR-OSHA Admin. Order 5-2003, f. 6/02/03, ef. 12/01/03.

## 437-007-0805 Mechanical Falling.

- (1) The minimum distance between mechanical falling machines or personnel must be twice the height of the trees being felled.

**NOTE:** Increase this distance where the operation of mechanical falling machines creates the possibility of thrown or flying objects.

- (2) Mobile tree falling machines must be designed or have attachments installed to cause the tree to fall in the intended direction.

**Stat. Auth.:** ORS 654.025(2) and 656.726(4).  
**Stats. Implemented:** ORS 654.001 through 654.295.  
**Hist:** OR-OSHA Admin. Order 5-2003, f. 6/02/03, ef. 12/01/03.

**437-007-0810 Manual Falling.**

- (1) Falling cuts must not be made in a standing tree while anybody is in the area where the tree could fall.
- (2) Trees must not be felled if the wind is strong enough to prevent the tree from falling in the desired direction.
- (3) Domino falling is prohibited.
- EXCEPTION:** A lodged tree can be dislodged by falling another tree into it.
- (4) A worker must not:
- (a) Work under a lodged tree.
  - (b) Cut a tree that another tree is lodged in.
- (5) When any lodged or standing tree with undercuts or back cuts is left unattended, the hazardous area must be distinctly marked by hazard identification ribbon as specified in OAR 437-007-0205.
- (6) Only qualified workers may fall danger trees.
- (7) When falling danger trees:
- (a) Use extra caution.
  - (b) Remove loose bark within reach from the ground before starting to fall the tree.
  - (c) Use a deep undercut with a wide face opening, and fall the danger tree in the direction of lean whenever possible to avoid vibration caused by wedging.
- (8) One worker must not fall a tree or danger tree when the assistance of another worker is necessary to minimize the risk of injury caused by overhead hazards, loose bark, loose or interlocked limbs, conditions of the tree, terrain or cutting conditions.
- (9) An escape route must be determined and arranged before a tree is fallen so the worker(s) falling the tree can move at least 25 feet away from and to the side of the base of the tree.
- (10) The escape route must be clear of brush, snow, tools and other material that would impede a quick escape.
- (11) Workers must not remain at the stump as the tree falls unless it is necessary to complete the backcut. Once the backcut is completed, the worker must immediately release the throttle and move a safe distance away from the tree.

- (12) Trees must be felled into the open whenever practical.
- (13) When manual falling or tree jacking, trees must not be felled directly uphill when the probability of the tree sliding back past the stump is likely.
- (14) When manual falling or tree jacking, trees felled uphill must be quartered to the slope, to minimize exposure to sliding or rolling trees.
- (15) When trees or snags are over 6 inches DBH:
- (a) Undercuts must not be less than 1/4 the diameter of the tree.
  - (b) Face openings must not be less than 1/5 the diameter of the tree.

*EXAMPLE: Acceptable undercuts:*

**A. Conventional undercut.** Can be made with parallel saw cut and axe diagonal cut or both cuts with the saw. Generally used on trees of small diameter.

**Figure 7-35 – Falling – Conventional Face**



**B. Humbolt cut.** Both cuts made with the saw. Same as "A" except that waste is put on the stump.

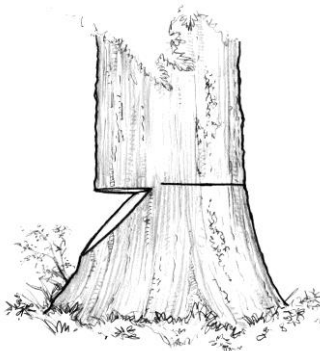

**Figure 7-36 – Falling – Humbolt Face**

**C. Open face cut.** Both cuts made with the saw. The top and bottom face cuts generally form a 90 degree angle when completed. Works best on small diameter trees.

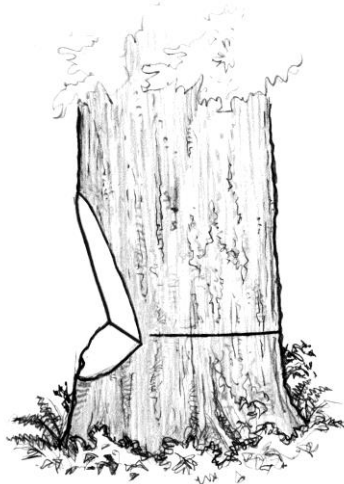

**Figure 7-37 – Falling – Open Face**

**(16)** Undercuts must be completely removed and cleaned out unless it is necessary to use a Dutchman on either side of the cut.

**(17)** Undercuts and back cuts must be made at a sufficient height above the highest ground level to enable the person falling the tree to:

- (a)** Safely make the cut.
- (b)** Control the tree.
- (c)** Have freedom of movement for a quick escape.

**(18)** Back cuts must be made above and on a horizontal plane with the face cut.

**(19)** Holding wood must not be completely cut through.

**NOTE:** When completing a swing cut, sufficient holding wood must be maintained to guide the tree during most of its fall.

**Stat. Auth.:** ORS 654.025(2) and 656.726(4).

**Stats. Implemented:** ORS 654.001 through 654.295.

**Hist:** OR-OSHA Admin. Order 5-2003, f. 6/02/03, ef. 12/01/03.

# WEDGES / BUCKING TREES/LOGS

## **437-007-0815 Wedges.**

- (1) Wedges must be driven with a hammer or other suitable tool.
- (2) Two wedges must be immediately available when falling trees over 15 inches DBH.
- (3) Wedges must be used when falling trees that:
  - (a) Are over 15 inches DBH.
  - (b) Do not have a predictable lean.

**Stat. Auth.:** ORS 654.025(2) and 656.726(4).

**Stats. Implemented:** ORS 654.001 through 654.295.

**Hist:** OR-OSHA Admin. Order 5-2003, f. 6/02/03, ef. 12/01/03.

## **437-007-0820 Bucking Trees/Logs.**

- (1) Fallers and buckers working as a team must keep each other informed of their location.
- (2) When a worker is bucking, they must give a timely warning to others within range of any log that may move after being cut off.
- (3) Only qualified workers must buck windfalls.
- (4) Before workers start bucking, they must carefully examine the tree or log to determine which way logs will roll, drop or swing.
- (5) A worker must not buck a tree or log on the downhill side unless they:
  - (a) Are in a safe location.
  - (b) Block or secure the tree to prevent rolling.
- (6) Before a worker starts to buck a tree or log they must:
  - (a) Clear away brush and other material which might interfere with a quick escape.
  - (b) Establish firm footing.
- (7) Logs that are not completely bucked through must be conspicuously marked with hazard identification ribbon as required by 437-007-0205(1) through (5).
- (8) Two or more persons must not buck the same tree or log at the same time.

**Stat. Auth.:** ORS 654.025(2) and 656.726(4).

**Stats. Implemented:** ORS 654.001 through 654.295.

**Hist:** OR-OSHA Admin. Order 5-2003, f. 6/02/03, ef. 12/01/03.

**437-007-0825 Tree Jacking.**

(1) Hydraulic tree jacks must have:

(a) An internal operable load check valve, velocity fuse or equivalent device. When using hoses with a jack, the device must be installed between the ram and the first piece of hose out from the jack.

(b) An operable pressure gauge.

(2) If two or more tree jacks are used and operated with one pump, a one-way flow valve must be used to isolate the hydraulic fluid from one jack to another jack should a failure in the system occur.

(3) A qualified person must determine if it is safe to jack a tree.

(4) Hydraulic tree jacks must have enough lift power for the trees to be jacked and felled.

(5) Two workers, one of whom must be qualified in the use of jacks, must be present at the tree when using hydraulic tree jacks.

(6) The jack seat of hydraulic tree jacks must be level.

(7) A metal plate or pad must be placed between the ram and the saw cuts when using a hydraulic tree jack. The metal plate or pad must be of sufficient area and have a surface design to prevent the plate or pad from sinking into the wood or from slipping.

(8) The hydraulic tree jack seat must be on solid wood inside the bark ring.

**Stat. Auth.:** ORS 654.025(2) and 656.726(4).

**Stats. Implemented:** ORS 654.001 through 654.295.

**Hist:** OR-OSHA Admin. Order 5-2003, f. 6/02/03, ef. 12/01/03.

# TREE PULLING

I

## **437-007-0830 Tree Pulling.**

- (1)** A qualified person must determine if it is safe to pull a tree.
- (2)** Positive communications must be maintained at all times between the tree-pulling machine operator and the person falling the tree. Citizens' band radios are not considered positive communications.
- (3)** An audible signal must be sounded when the initial pull is made on the tree and the line is tightened.
- (4)** A choker, choker bell or a line with a sleeve shackle must be used as the means of attachment around the tree when tree-pulling. The bight on the line must be only that necessary to hold the choker or line around the tree.
- (5)** The tree-pulling machine must be equipped with a torque converter, fluid coupler or an equivalent device to ensure a steady, even pull on the line attached around the tree.
- (6)** The tree-pulling line must have as straight and direct a path from the machine to the tree as possible. Physical obstructions which prevent a steady, even pull on the tree-pulling line must be removed or the line must be rerouted.
- (7)** The use of a siwash, in lieu of using a block and strap for the purpose of changing the tree-pulling lead, is prohibited.
- (8)** In tree pulling operations, the back cut may be below and on a horizontal plane with the face cut.

**Stat. Auth.:** ORS 654.025(2) and 656.726(4).

**Stats. Implemented:** ORS 654.001 through 654.295.

**Hist:** OR-OSHA Admin. Order 5-2003, f. 6/02/03, ef. 12/01/03.

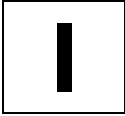

**TABLE OF CONTENTS**

<b>437-007-0900</b>	General Landing Work Practices .....	J-1
<b>437-007-0905</b>	Landings .....	J-2
<b>437-007-0910</b>	Landing Logs .....	J-3
<b>437-007-0915</b>	Log Decks.....	J-4
<b>437-007-0920</b>	General Cable Yarding and Ground Skidding Work Practice.....	J-4
<b>437-007-0925</b>	Cable Yarding Work Practices .....	J-5
<b>437-007-0927</b>	Working Near Standing Tree Anchors, and Tail/Intermediate Support Trees .....	J-6
<b>437-007-0930</b>	Grapple Yarding .....	J-7
<b>437-007-0935</b>	Operation of Ground Skidding Machines and Vehicles .....	J-8
<b>437-007-0940</b>	Signaling and Communications.....	J-9
<b>437-007-0945</b>	Electrical Signal Systems .....	J-10
<b>437-007-0950</b>	Voice Communication on Combined Signal/Voice Transmitters .....	J-11

**J**

Oregon Administrative Rules  
Oregon Occupational Safety  
and Health Division

# GENERAL LANDING WORK PRACTICES

# J

## **437-007-0900 General Landing Work Practices.**

- (1)** Before starting or moving any machine, the operator must determine that personnel are in the clear.
- (2)** When vehicles or machines are moved within the landing area all personnel must:
  - (a)** Stay in the clear of the vehicle(s) or machine(s).
  - (b)** Inform the operator of the intent to approach or be near the vehicle(s) or machine(s).
  - (c)** Wait for the operator's permission to approach or be near the vehicle(s) or machine(s).
- (3)** Personnel must not approach the hazardous pinch point area created by the rotation of the machine's superstructure without:
  - (a)** Informing the operator of that intent.
  - (b)** Receiving acknowledgment from the operator that the person's intention is understood.
  - (c)** The machine being stopped while personnel are within the hazardous area.

**NOTE:** OAR 437-007-0700 General Work Practices, paragraphs (1) through (3) from Division 7/H, are reprinted here.

## **437-007-0700 General Work Practices.**

- (1)** Machines must be operated at a sufficient distance from personnel and other machines to not create a hazard for any person.
- (2)** An unimpaired horizontal clearance of not less than 3 feet must be maintained between the rotating superstructure of any machine and any adjacent object or surface. If this clearance cannot be maintained, personnel must be warned of the pinch point area. Measures taken to warn personnel of the pinch point area may consist of a warning line constructed of rope or ribbon supported on stanchions, barriers, cones, flags, etc.
- (3)** Items of personal property, tools or other miscellaneous materials must not be stored on or within 3 feet of any machine if such items would expose personnel to hazards caused by the rotation of the machine's superstructure.

**EXCEPTION:** These items may be stored within 3 feet when in a locked box or otherwise secured and under the exclusive control of the equipment operator.

# J

## GENERAL LANDING WORK PRACTICES / LANDINGS

Oregon Administrative Rules  
Oregon Occupational Safety  
and Health Division

- (4) Any tool or rigging that is not being used must be stored in a location where it will not create a hazard.
- (5) Materials must not be pushed, thrown or dumped off the landing in a manner or at a time that will endanger personnel.
- (6) Personnel must not brand, mark, buck, limb or trim logs in a location that will expose them to contact with moving lines, logs, rigging, machines, equipment or vehicles.
- (7) Logs must not be placed in, moved about, or removed from the bucking area of the landing unless all personnel are in the clear.
- (8) Tonges must not be carried over both shoulders with the tong points around the neck.

**Stat. Auth.:** ORS 654.025(2) and 656.726(4).

**Stats. Implemented:** ORS 654.001 through 654.295.

**Hist:** OR-OSHA Admin. Order 5-2003, f. 6/02/03, ef. 12/01/03.

### 437-007-0905 Landings.

#### (1) Landing areas must be:

- (a) Large and level enough to land, heel, tail/swing or process logs without striking standing timber, rigging, trucks, vehicles, equipment, other machines or objects.

**NOTE:** This is not intended to restrict the occasional yarding or loading of logs for poles, piling or an infrequent long break or tree length, provided the log is stabilized before unhooking the choker.

- (b) Large enough for safe movement of all machinery.
- (c) Kept chunked out and have an even surface.

#### (2) Outrigger pads, tracks or wheels must be on firm, stable ground, cribbing or prepared surface.

#### (3) During road side thinning, logs stacked on the road side must be placed in a stable position.

#### (4) Roadside or continuous landings must be wide enough to safely operate the yarding and loading equipment.

**Stat. Auth.:** ORS 654.025(2) and 656.726(4).

**Stats. Implemented:** ORS 654.001 through 654.295.

**Hist:** OR-OSHA Admin. Order 5-2003, f. 6/02/03, ef. 12/01/03.

OR-OSHA Admin. Order 2-2005, f. 5/27/05, ef. 6/1/05.

## **437-007-0910 Landing Logs.**

**(1)** Logs must not be landed until all personnel, trucks, machines, or vehicles are in the clear.

**(2)** After a turn is landed, all rigging must be completely stopped and logs must be stable before:

**(a)** Being approached by personnel.

**(b)** Chokers are unhooked.

**(3)** When chokers are manually unhooked, the yarder operator must receive a signal from the chaser before any lines are moved.

**(4)** Logs must not be permitted to accumulate in the landing chute to the point where they become a hazard.

**(5)** When yarding uphill, the landing chute must be cleared of logs before the next turn of logs is landed unless:

**(a)** The logs are fully contained in the landing chute; or

**(b)** There is no possibility that personnel working below the landing may be struck by sliding or rolling logs or materials coming off the landing.

**(6)** Logs must not be disturbed or moved from the chute when personnel working below could be struck by logs, chunks or other material sliding or rolling off the landing.

**(7)** The following apply when logs are landed. When the landing slope is:

**(a)** Twenty percent or less, logs may be landed and decked in the chute provided the logs can be left in a stable position.

**(b)** More than 20 percent, decking is not permitted in the chute if:

**(A)** A chaser is required to unhook the rigging from the logs.

**(B)** Personnel are working below the landing chute.

**Stat. Auth.:** ORS 654.025(2) and 656.726(4).

**Stats. Implemented:** ORS 654.001 through 654.295.

**Hist:** OR-OSHA Admin. Order 5-2003, f. 6/02/03, ef. 12/01/03.

# J

## LOG DECKS / GENERAL CABLE YARDING & GROUND SKIDDING WORK PRACTICES

Oregon Administrative Rules  
Oregon Occupational Safety  
and Health Division

### 437-007-0915 Log Decks.

- (1) Logs must be placed in and removed from decks in an orderly manner to minimize rolling or shifting.
- (2) Logs must not be decked in a location where they will slide or roll in the direction of personnel, vehicles, equipment or machines.
- (3) Logs must be rearranged or decked at a different location if the landing process or weather conditions (rain, snow, ice, mud) prevent log stability and personnel are exposed to the hazard of rolling or sliding logs.

**Stat. Auth.:** ORS 654.025(2) and 656.726(4).

**Stats. Implemented:** ORS 654.001 through 654.295.

**Hist:** OR-OSHA Admin. Order 5-2003, f. 6/02/03, ef. 12/01/03.

### 437-007-0920 General Cable Yarding and Ground Skidding Work Practices.

- (1) The requirements of OAR 437-007-0225(1) and (2) (working near unstable objects and danger trees) apply to all cable yarding and ground skidding operations, especially when yarding downhill.
- (2) Choker holes must be dug from the uphill side of the log when there is danger of the log rolling or moving.
- (3) Chokers must be placed near the end of logs.  
  
**NOTE:** Chokers may be placed in the middle of the log ("gut shot") if it will provide greater control when the turn is yarded or landed.
- (4) Personnel must not stand on or near logs, root wads, or other objects which may be moved by the turn of logs.
- (5) Before the go-ahead signal is given personnel must:
  - (a) Move to the side and behind all logs in the turn and be in the clear.
  - (b) Remain on their feet and face the turn.
  - (c) Stay in the clear until it is safe to return to the area where chokers are being set.
- (6) When approaching or working around hang-ups, personnel must:
  - (a) Approach from above the hang-up.
  - (b) Be alert to the danger of logs rolling or sliding, siwashes, widow makers and danger trees.

# GENERAL CABLE YARDING & GROUND SKIDDING WORK PRACTICES / CABLE YARDING WORK PRACTICES

# J

(7) Workers must not ride on arches, reaches and turns of logs.

**Stat. Auth.:** ORS 654.025(2) and 656.726(4).

**Stats. Implemented:** ORS 654.001 through 654.295.

**Hist:** OR-OSHA Admin. Order 5-2003, f. 6/02/03, ef. 12/01/03.

## 437-007-0925 Cable Yarding Work Practices.

(1) Personnel must not ride hooks, lines, rigging, logs suspended in the air or being moved.

(2) Personnel must not hold onto haywire, running lines, drop lines or chokers as an assist when walking uphill.

(3) Personnel must not work in the bight of lines under tension.

**EXCEPTIONS:** Personnel may be in the bight of lines when:

(a) Minor positioning of the rigging is needed to set chokers.

(b) They are protected by standing timber, terrain, or other objects of sufficient size to assure their safety.

**NOTE:** "Lines under tension" means when:

(a) Logs are being moved or suspended.

(b) The rigging or carriage is moving to the landing or returning to the brush.

(c) Lines are tight-lined to clear up the road.

(d) Any movement or tightening of the line(s) other than that needed for minor positioning of the rigging or carriage to set chokers.

(4) Personnel must be in the clear of all lines, rigging and chokers until movement has stopped. Swinging chokers, hooks and rigging must be lowered to the ground.

(5) Personnel must be in the clear of trees, logs, root wads, chunks, rolling material, all lines and rigging before any lines are moved.

(6) Personnel must not stand next to skyline or running line anchor straps under tension.

(7) A minimum of one choker setter in each crew must be a qualified choker setter.

(8) Only one employee in any crew can give signals or voice communication at the point where chokers are being set.

**NOTE:** Any person is authorized to give a stop signal when an employee is in danger or any other emergency condition is apparent.

<b>J</b>	<b>CABLE YARDING WORK PRACTICES / WORKING NEAR STANDING TREE ANCHORS &amp; TAIL/INTERMEDIATE SUPPORT TREES</b>	Oregon Administrative Rules Oregon Occupational Safety and Health Division
----------	--	--

**(9)** At least two members of the rigging crew must carry transmitters for each signal and control system being operated where chokers are being set.

**(10)** When only one person is setting chokers on any cable yarding system, they must:

**(a)** Carry transmitters for each signal and control system being operated where chokers are being set.

**(b)** Be in clear view of the yarder operator or another person with transmitters for each signal and control system being operated where chokers are being set.

**Stat. Auth.:** ORS 654.025(2) and 656.726(4).

**Stats. Implemented:** ORS 654.001 through 654.295.

**Hist:** OR-OSHA Admin. Order 5-2003, f. 6/02/03, ef. 12/01/03.

### **437-007-0927 Working Near Standing Tree Anchors, and Tail /Intermediate Support Trees.**

**(1)** Affected personnel must be notified of the potential failure zone of any tail tree, intermediate support tree and standing tree anchor.

**NOTE:** The potential failure zone is that area which could be impacted by the failure of any part of a tail tree, intermediate support tree or standing tree anchor as the result of forces or loads imposed on the tree by guylines, running lines or skylines.

**(2)** The boundaries of the potential failure zone must be determined by a competent person.

**(3)** The boundaries of the potential failure zone must encompass the area into which the tree or parts of the tree could fall, slide or roll and all trees, logs, lines and material that could be impacted by the tree failure.

**(4)** Personnel must be in the clear of the turn and out of the potential failure zone of a standing tree skyline or running line anchor before lines are tensioned.

**NOTE:** Personnel may be in the potential failure zone when minor positioning of the rigging is needed or to set chokers.

**NOTE:** "Before lines are tensioned" means before:

**(a)** Logs are moved or suspended.

**(b)** The rigging or carriage is moved to the landing or returned to the brush.

**(c)** Lines are tight-lined to clear up the road.

**(d)** Any movement or tightening of the line(s) other than that needed for minor positioning of the rigging or carriage to set chokers.

## WORKING NEAR STANDING TREE ANCHORS & TAIL/INTERMEDIATE SUPPORT TREES / GRAPPLE YARDING

J

**(5)** Personnel working around tail and intermediate support trees must be in the clear of the turn and out of the potential failure zone before lines are tensioned.

**NOTE:** Personnel may be in the potential failure zone when minor positioning of the rigging is needed or to set chokers.

**(6)** If the potential failure zone cannot be determined, personnel must move at least 1 1/2 tree lengths from the base of tail and intermediate support trees, and in the clear before lines are tensioned.

**(7)** A competent person must instruct affected personnel in the safe work practices required for work activity in any potential failure zone. This instruction must identify the:

**(a)** Boundaries of the potential failure zone

**(b)** Potential for the boundaries of the failure zone to change when line pull and line angles change.

**(c)** Limitations or restrictions for entering or working in the potential failure zone.

**Stat. Auth.:** ORS 654.025(2) and 656.726(4).

**Stats. Implemented:** ORS 654.001 through 654.295.

**Hist:** OR-OSHA Admin. Order 5-2003, f. 6/02/03, ef. 12/01/03.

### **437-007-0930 Grapple Yarding.**

**(1)** An audible signal does not need to be sounded before lines are moved while grapple yarding if employees are not exposed to logs or rigging movement.

**(2)** Chokers must not be set when using a grapple yarding system during:

**(a)** Hours of darkness.

**(b)** Periods when visibility is reduced to such an extent that the yarder operator cannot clearly see the person setting the choker.

**(3)** One person carrying a whistle signaling device may use voice communications to transmit instructions and directions to the yarder operator when picking up an occasional log with a choker on a grapple yarding system only:

**(a)** During daylight hours.

**(b)** When the choker setter is in clear view of the yarder operator at all times.

**(c)** When all lines are slacked to the ground prior to the choker setter approaching the rigging.

# J

## GRAPPLE YARDING / OPERATION OF GROUND SKIDDING MACHINES AND VEHICLES

Oregon Administrative Rules  
Oregon Occupational Safety  
and Health Division

(d) When all lines remain stable until the choker setter returns to a safe location away from any running lines.

(4) Standard yarding system whistle signals must be used when the choker setter is not in clear view of the yarder operator when chokers are set on grapple yarding systems. (See Appendix 7-A.)

**Stat. Auth.:** ORS 654.025(2) and 656.726(4).

**Stats. Implemented:** ORS 654.001 through 654.295.

**Hist:** OR-OSHA Admin. Order 5-2003, f. 6/02/03, ef. 12/01/03.

### 437-007-0935 Operation of Ground Skidding Machines and Vehicles.

(1) Machines must not be operated on slopes in excess of the following limits unless specified by the manufacturer of the equipment.

(a) Rubber-tired skidders – 30 percent.

(b) Crawler tractors, tracked feller bunchers, tracked excavators and loaders – 40 percent.

(c) Other forestry equipment designed for steep slopes – 50 percent.

(2) Operation in excess of the above limits may be permitted for specific limited application or in identified small areas provided the operator and the competent person plan how to safely operate on the steep slopes considering the:

(a) Experience of the operator.

(b) Limitations of the machine and the soil conditions.

(c) Direction of travel (traveling straight up and down the slope).

(d) Requirements for turning the machine or vehicle on the slope.

(e) Weather.

(f) Load sizes.

(g) Any other adverse conditions.

(3) Turnarounds must be provided on all skidding roads so operators do not have to backup more than 250 feet.

(4) Towed equipment, such as skid pans, pallets, arches, and trailers, must be attached in a manner which will prevent overrunning of the towing vehicle, equipment or machine.

## OPERATION OF GROUND SKIDDING MACHINES & VEHICLES / SIGNALING AND COMMUNICATIONS

J

- (5) Tractors, skidders, arches, or logs being yarded must not run over or rub against anchored lines, tailhold stumps, or other rigging.
- (6) The yarding machine or vehicle, including its load, must be operated with safe clearance from trees, snags, logs, or other objects that may create a hazard for an employee.
- (7) Each machine must be positioned during winching so the machine and winch are operated within their design limits.
- (8) No load can exceed the rated capacity of the pallet, trailer, or other carrier.
- (9) Arches must be equipped with line guards.

**Stat. Auth.:** ORS 654.025(2) and 656.726(4).

**Stats. Implemented:** ORS 654.001 through 654.295.

**Hist:** OR-OSHA Admin. Order 5-2003, f. 6/02/03, ef. 12/01/03.  
OR-OSHA Admin. Order 2-2005, f. 5/27/05, ef. 6/1/05.

### **437-007-0940 Signaling and Communications.**

- (1) Hand signals or audible contact, such as, but not limited to, whistles, horns, or radios, must be used whenever noise, distance, restricted visibility, or other factors prevent clear understanding of natural unassisted voice communications between employees.
- (2) A whistle or horn, clearly audible and distinguishable to all personnel in the affected area, must be installed and used on all machines operating as yarders, loaders or tree pullers.
- (3) All radio-controlled carriages and motorized skycars must have a warning horn which is sounded when any carriage function is activated.
- (4) Standard yarding system whistle signals identified in Appendix 7-A must be used at cable logging operations.
- (5) A new yarding system whistle signal may be adopted for an unusual or new situation not covered in the standard whistle signals provided:
  - (a) The new signal is used only for that specific situation.
  - (b) All employees are informed of the new signal.
- (6) A list of the standard yarding whistles, any new yarding system whistle(s) and control system signals used to activate cable logging systems, machinery and equipment functions must be available at the work site.
- (7) Affected personnel must understand the control system signals, hand signals and whistles used to activate equipment and machines.

# J

## SIGNALING AND COMMUNICATIONS / ELECTRICAL SIGNAL SYSTEMS

Oregon Administrative Rules  
Oregon Occupational Safety  
and Health Division

- (8) All audible signal systems, equipment and machinery activation signals must be tested and be fully functional prior to beginning the operation.
- (9) Spare transmitters must be guarded against accidental activation.
- (10) All personnel must be in the clear before any signal is given to move any log, load, rigging, or turn.
- (11) Machine operators must not move any lines, logs, loads or rigging unless the signal received is clear and distinct. If in doubt, the operator must repeat the signal as understood and wait for confirmation.
- (12) An audible signal must always be sounded before any line is moved.
- (13) Voice communication, except as required by 437-007-0950(1), may be used to transmit instruction and direction to the yarder operator to move rigging and control the movement of logs provided that an audible signal is sounded before any line is moved.
- (14) An audible signal does not need to be sounded when yarding logs with grapples if personnel are not exposed to line, log or rigging movement.
- (15) When hand signals are used, an audible signal does not need to be sounded when personnel are aware of and not exposed to line, log or rigging movement.
- (16) Hand signals may only be used:
- (a) In plain sight of the machine operator.
  - (b) Within 300 feet of the machine operator.
- NOTE:** Hand signals may be used at any time as an emergency stop signal.
- (17) Throwing of any type of material as a signal is prohibited.
- (18) Citizens' band (CB) radios cannot be used to activate any signal, machine or process either automatically or by voice.

**Stat. Auth.:** ORS 654.025(2) and 656.726(4).

**Stats. Implemented:** ORS 654.001 through 654.295.

**Hist:** OR-OSHA Admin. Order 5-2003, f. 6/02/03, ef. 12/01/03.

### **437-007-0945 Electrical Signal Systems.**

- (1) All electrical signal system wires and attachments must be weatherproof.
- (2) Electrical signal systems must be:
- (a) Installed and adjusted to protect against accidental signaling.

## VOICE COMMUNICATION ON COMBINED SIGNAL/VOICE TRANSMITTERS

**J**

(b) Maintained in good operating condition.

(3) Electrical signal system bugs (transmitter) must be designed so they cannot be accidentally tripped.

**Stat. Auth.:** ORS 654.025(2) and 656.726(4).

**Stats. Implemented:** ORS 654.001 through 654.295.

**Hist:** OR-OSHA Admin. Order 5-2003, f. 6/02/03, ef. 12/01/03.

### **437-007-0950 Voice Communication on Combined Signal/Voice Transmitters.**

(1) Voice communication on the same radio frequencies used to transmit skyline, high-lead, slackline or skidder whistle signals (154.57 and 154.60 MHz channels), is limited to the reporting of injuries, or fire and emergency situations where special tools or precautions are needed to prevent or alleviate a hazardous situation. In addition:

(2) Voice transmissions must not be used to move the rigging and only used when the rigging is standing still.

(3) The rigging crew must call the yarder engineer by name to ensure that proper contact is established.

(4) The yarder engineer must acknowledge the call with a whistle "STOP" signal before the caller starts transmitting the voice message.

(5) Voice transmission must be kept as brief and to the point as possible.

(6) After receiving the voice message, the yarder engineer must again acknowledge with a whistle "STOP" signal that the message has been received and is clearly understood.

**Stat. Auth.:** ORS 654.025(2) and 656.726(4).

**Stats. Implemented:** ORS 654.001 through 654.295.

**Hist:** OR-OSHA Admin. Order 5-2003, f. 6/02/03, ef. 12/01/03.

**J**

Oregon Administrative Rules  
Oregon Occupational Safety  
and Health Division

# LOADING AND TRANSPORTATION OF LOGS/WOOD FIBER

# K

## TABLE OF CONTENTS

<b>437-007-1000</b>	General Requirements .....	K-1
<b>437-007-1005</b>	Loading .....	K-1
<b>437-007-1010</b>	Securing Logs for Transport.....	K-3
<b>437-007-1015</b>	Binders and Wrappers .....	K-4
<b>437-007-1020</b>	Log Truck General Requirements .....	K-6
<b>437-007-1025</b>	Log Truck Safety Chains or Cables .....	K-7
<b>437-007-1030</b>	Log Truck and Trailer Hitches (Couplings) .....	K-8
<b>437-007-1035</b>	Log Truck and Trailer Brakes.....	K-8
<b>437-007-1040</b>	Log Truck Trailer Reaches and Drawbars .....	K-9
<b>437-007-1045</b>	Log Truck Trailers .....	K-9
<b>437-007-1050</b>	Log Truck and Trailer Bunks and Stakes.....	K-10
<b>437-007-1055</b>	Log Truck and Trailer Bunk Chains and Cables.....	K-11
<b>437-007-1060</b>	Additional Requirements for Log Trucks Equipped With Self Loaders	K-12

**K**

Oregon Administrative Rules  
Oregon Occupational Safety  
and Health Division

**437-007-1000 General Requirements.**

- (1) Trucks or rail cars must not be moved unless all personnel are in the clear.
- (2) When the operator's vision is impaired, trucks or rail cars must not be moved without a signal from a spotter who has a clear view of the direction of travel.
- (3) Trucks must not approach a landing while there is danger from incoming logs, logging machines, lines, or rigging.

**Stat. Auth.:** ORS 654.025(2) and 656.726(4).

**Stats. Implemented:** ORS 654.001 through 654.295.

**Hist:** OR-OSHA Admin. Order 5-2003, f. 6/02/03, ef. 12/01/03.

**437-007-1005 Loading.**

- (1) It is the responsibility of the employer who has control of the actual loading operation to ensure compliance with OAR 437-007-1005(2) through (18) and 437-007-1010(1) through (13) which are applicable to log loading, securing loads and to the requirement for hard hats.
- (2) The truck driver and personnel loading logs must use positive means of communication to control the movement of the truck being loaded.
- (3) Citizens' band (CB) radios may be used for communication between the loader operator and the log truck driver during the loading process.
- (4) Standing underneath a suspended trailer or its reach is prohibited.
- (5) Only the driver and driver-trainee are permitted to be in the truck cab while logs are being loaded.
- (6) Logs being moved or loaded must not pass over any personnel, occupied vehicles, machines, or truck cab.
- (7) Personnel must not enter any hazardous area near a log truck being loaded without:
  - (a) Determining that it is safe to enter the area.
  - (b) Receiving permission from the loading machine operator and truck driver.
  - (c) The centers of all logs are below the top of the stakes or secured by the log loader.

*NOTE: Hazardous areas include the areas:*

- (A) Between the deck or decks from which the logs are being removed.
- (B) Over which the logs are carried to place them on the log truck.
- (C) Along both sides of the log truck behind the cab guard.
- (D) Underneath the load.

(8) Logs must not be lowered to the bunk while bunk or block adjustments are being made.

(9) Standing between a truck cab and a log being loaded or unloaded is prohibited.

(10) Bunk and wing logs must extend at least 6 inches beyond the front and rear bunk or stake.

(11) Loads must be built up or loaded so they are stable without the use of wrappers.

*NOTE: Wrappers are considered to be a precautionary measure to ensure stability of the load during transit.*

(12) Logs must be loaded in a manner to prevent excessive strain on wrappers, binders, bunk stakes, bunk chains, or straps.

(13) When there is danger of a log slipping out of the grapples, a strap of sufficient size and length must be used to hold the log.

(14) The closing line must be securely attached to the grapple in accordance with the manufacturer's recommendations.

(15) Double-ended logs must not be loaded above the stakes on the side of the load from which the binders or wrappers are intended to be applied or released.

(16) Logs must be loaded so no more than 1/3 of the length of the logs extends beyond the:

- (a) Trailer bunks.
- (b) Ends of supporting logs.

(17) Log loads must not impair full and free movement of the truck.

(18) Loads or logs must not be moved or shifted while binders are being applied or adjusted.

**Stat. Auth.:** ORS 654.025(2) and 656.726(4).

**Stats. Implemented:** ORS 654.001 through 654.295.

**Hist:** OR-OSHA Admin. Order 5-2003, f. 6/02/03, ef. 12/01/03.

## **437-007-1010 Securing Loads for Transport.**

- (1)** Wrappers must not be thrown until personnel are in the clear.
- (2)** When logs are loaded at different locations or decks, log trucks must not be moved until the requirements for securing loads are met unless:
  - (a)** The centers of all logs are below the top of the stakes, or
  - (b)** Ground personnel and machines are not exposed to the hazard of falling logs or wood fiber.
- (3)** A fully loaded truck must not be moved more than 1 1/2 truck and trailer lengths in front of the loading area unless:
  - (a)** The centers of all logs are below the top of the stakes, or
  - (b)** The load is secured with at least two wrappers.
- (4)** All wrappers that are required to transport the load must be put on the load within sight of the loading area.
- (5)** Required wrappers and binders must be in place and hooked prior to tightening any of the binders.
- (6)** When drivers cannot safely throw wrappers over loads, alternate methods must be used, such as, pulling the wrappers over the load with the loading grapples. If the loaded truck is moved, the movement must comply with the requirements of OAR 437-007-1010(3).
- (7)** Loads must be secured as follows:
  - (a)** Any long logs (27 feet or more in length) must be secured with not less than four evenly spaced wrappers.

*EXCEPTION: Loads consisting of only four long logs or less may be secured with one wrapper at or near each bunk.*
  - (b)** All short logs (less than 27 feet in length) must be secured with at least two evenly spaced wrappers.
- (8)** Wrappers must be evenly spaced over the length of the logs.
- (9)** A wrapper must be placed near each bunk stake.
- (10)** Trucks and trailers used for off highway hauling on private haul roads where traffic controls are enforced:

**K****SECURING LOADS FOR TRANSPORT /  
BINDERS & WRAPPERS**Oregon Administrative Rules  
Oregon Occupational Safety  
and Health Division

- (a) Must meet the requirements of 437-007-1010(7), or
- (b) All perimeter logs must be contained by no less than two wrappers.
- (c) Wrappers must be placed near each end of the logs.
- (d) The two binders, chains, cables, fasteners, wrappers or other wrapper attachments must each have a minimum breaking strength of 20,000 pounds.

(11) Logs loaded crosswise on a truck or trailer without solid ends or stakes high enough to restrain the logs must be secured with at least two wrapper cables which are firmly attached to the ends of the truck or trailer.

(12) All wrappers, except for gut wrappers or a one-log load wrapper, must surround the entire load.

(13) Unless otherwise required, arrange binders so that they can only be released from the side of the vehicle away from the brow log or dumping side.

(14) Grab hooks must not be directly attached to the wrapper wire rope.

(15) All required wrappers must be kept tight during transit.

(16) Loose ends of wrappers must be secured to prevent the wrapper end from swinging and creating a hazard.

**Stat. Auth.:** ORS 654.025(2) and 656.726(4).

**Stats. Implemented:** ORS 654.001 through 654.295.

**Hist:** OR-OSHA Admin. Order 5-2003, f. 6/02/03, ef. 12/01/03.

**437-007-1015 Binders and Wrappers.**

(1) Each log truck must carry at least five binders and five wrappers.

(2) Binders, chains, cables, synthetic materials, fasteners, wrappers, or other wrapper attachments must each have a minimum breaking strength of not less than 15,000 pounds. The following components meet the 15,000-pound requirement:

(a) Chain of welded link construction:

(A) 5/16-inch alloy steel chain, or

(B) 3/8-inch high-test steel chain, or

- (b)** 7/16-inch IPS wire rope of 6 x 19 or 6 x 37 construction.
- (3)** Binders must have the manufacturer's name and minimum breaking strength stamped on the binder.
- (4)** Wrappers used to secure loads must not be used for any other purpose.
- (5)** Wrappers must be removed from service when:
  - (a)** Wear has reduced the original chain link diameter by 15 percent.
  - (b)** Chain links are deformed, stretched or cracked.
  - (c)** Wire rope is frayed, stranded, knotted or otherwise defective.
  - (d)** Wire rope has 12 1/2 percent of the wires broken within the distance of one lay.
- (6)** Binders must be removed from service when:
  - (a)** Wear has reduced the original pin diameter by 15 percent.
  - (b)** The yoke is spread.
  - (c)** Handles are bent or broken.
  - (d)** Hooks are bent or broken.
  - (e)** Chain links are deformed, stretched or cracked.
  - (f)** Swivels are defective.
- (7)** Defective binders, tighteners or other securing devices on binder chain or cable must be removed from service.
- (8)** Tighteners and other means of securing or attaching binder chain or cable must be used only in the manner for which they were intended.
- (9)** Welding on binders is prohibited.
- (10)** Knots must not be tied in wrappers.
- (11)** Binders for securing wrapper chain must have hooks of the correct size and design for the chain.

**K****BINDERS AND WRAPPERS /  
LOG TRUCK GENERAL  
REQUIREMENTS**Oregon Administrative Rules  
Oregon Occupational Safety  
and Health Division

**(12)** Extension handles (swedes) for tightening or securing binders must not be longer than 36 inches.

**(13)** Extension handles (swedes) used to tighten binders must be of the safety swede type.

**Stat. Auth.:** ORS 654.025(2) and 656.726(4).

**Stats. Implemented:** ORS 654.001 through 654.295.

**Hist:** OR-OSHA Admin. Order 5-2003, f. 6/02/03, ef. 12/01/03.

**437-007-1020 Log Truck General Requirements.**

**(1)** Manufacturers' handholds and steps provided on trucks must be maintained.

**(2)** The area between the truck frame rails, from the cab rearward as far as necessary to provide a safe work area, must have a walking surface of suitable non-slip material.

**(3)** Log trucks, with loads that are scaled at ramps, must have a personnel platform that:

**(a)** Extends outward from the side of each frame rail 18 inches.

**(b)** Is 18 inches long or as near 18 inches as the design of the truck will permit.

**(c)** Is capable of safely supporting a 500-pound load.

**(d)** Have a nonslip surface.

**(4)** There must be a step or other safe access for the driver to reach the space behind the cab.

**(5)** Log trucks must have a bulkhead meeting PUC requirements located between the load and cab. This bulkhead must extend to the top of the cab.

**(6)** All riders must be in the cab and use a seat and seat belt.

**(7)** Tire chain hooks must not present a hazard to workers. The arrangement and location of the tire chain hooks may include, but are not limited to:

**(a)** Under the scaler platform with the hook tips toward the center of the truck, or

**(b)** Inside an enclosure, such as a bottomless box attached to the truck frame, or

**(c)** Shielded with guards (such as hinged metal covers).

# LOG TRUCK GENERAL REQUIREMENTS / LOG TRUCK SAFETY CHAINS OR CABLES

# K

**(8)** Empty spare tire racks must be removed from bulkheads when there is no tire in them unless the lower part of the rack folds back against the upper part.

**(9)** Additional vehicle requirements that apply to log trucks are contained in Subdivision F, Roads and Vehicles, OAR 437-007-0520 through 437-007-0570.

**Stat. Auth.:** ORS 654.025(2) and 656.726(4).

**Stats. Implemented:** ORS 654.001 through 654.295.

**Hist:** OR-OSHA Admin. Order 5-2003, f. 6/02/03, ef. 12/01/03.

## **437-007-1025 Log Truck Safety Chains or Cables.**

**(1)** Each log truck and trailer combination, and each independent trailer (mule train) hooked to a log truck and trailer combination must have one or more safety chains or cables with a rated breaking strength of not less than the gross weight of the towed trailer(s).

**(2)** The means of attachment for safety chains or cables must:

**(a)** Be securely attached to the truck frame or to the truck frame extension.

**(b)** Form a separate continuous connection between the truck frame or truck frame extension and the reach.

**(c)** Be attached within 12 inches of the reach eye.

**(d)** Provide strength equivalent to the chain or cable.

**(3)** Safety chains or cables must:

**(a)** Prevent the trailer reach from contacting the ground in the event of disengagement from the truck.

**(b)** Provide a positive connection that cannot become inoperative by any condition of use or exposure.

**(4)** Safety chains must be replaced when they have cuts, cracks or wear has reduced the chain diameter by 15 percent.

**(5)** Safety cables must be replaced when the wire rope is frayed, stranded, 12 1/2 percent of the wires are broken within the distance of one lay or is otherwise defective.

**(6)** Safety chain links must not be welded except to close cold-shut links.

<b>K</b>	<b>LOG TRUCK SAFETY CHAINS OR CABLES / LOG TRUCK &amp; TRAILER HITCHES (COUPLINGS) / LOG TRUCK &amp; TRAILER BRAKES</b>	Oregon Administrative Rules Oregon Occupational Safety and Health Division
----------	---	--

(7) Use cold-shut links only if they are:

- (a) Welded.
- (b) One size larger than the chain being used.

**Stat. Auth.:** ORS 654.025(2) and 656.726(4).  
**Stats. Implemented:** ORS 654.001 through 654.295.  
**Hist:** OR-OSHA Admin. Order 5-2003, f. 6/02/03, ef. 12/01/03.

### **437-007-1030 Log Truck and Trailer Hitches (Couplings).**

(1) All log truck and trailer combinations must be equipped with couplings (hitches) that:

- (a) Will withstand, in any direction, the potential stresses imposed.
- (b) Have two independent locking devices that will continue working despite dirt and debris.
- (c) Remain securely locked.
- (d) Are attached to the truck frame or extension with at least four machine bolts (120,000 PSI or stronger), 3/4-inch or larger in diameter and secured with lock nuts.

(2) Hitches (couplings) having parts that are broken, cracked, worn, deformed more than 1/4-inch or are otherwise defective must be removed from service until repaired to comply with the manufacturer's specifications.

**Stat. Auth.:** ORS 654.025(2) and 656.726(4).  
**Stats. Implemented:** ORS 654.001 through 654.295.  
**Hist:** OR-OSHA Admin. Order 5-2003, f. 6/02/03, ef. 12/01/03.

### **437-007-1035 Log Truck and Trailer Brakes.**

- (1) Truck and trailer brakes must be tested before moving any load.
- (2) Brake slack adjusters must be adjusted to meet DOT specifications.
- (3) Vehicles with defective brakes must not be operated.
- (4) Brake drums must not be welded.
- (5) Engine-type brakes must be considered auxiliary controls, not a substitute for the primary braking systems.
- (6) Air or vacuum brake lines and fittings must be approved for brake line systems and not be interchangeable with water or other lines.

**LOG TRUCK & TRAILER BRAKES /  
LOG TRUCK TRAILER  
REACHES & DRAWBARS /  
LOG TRUCK TRAILERS**

**K**

(7) Splices in air brake lines must:

- (a) Be made with fittings approved for air brake line service.
- (b) Not restrict air flow below the minimum required for the line size.

(8) If disconnected trailers are not equipped with effective brakes, wheels must be chocked, blocked or the trailer must be otherwise secured.

**Stat. Auth.:** ORS 654.025(2) and 656.726(4).  
**Stats. Implemented:** ORS 654.001 through 654.295.  
**Hist:** OR-OSHA Admin. Order 5-2003, f. 6/02/03, ef. 12/01/03.

**437-007-1040 Log Truck Trailer Reaches and Drawbars.**

(1) The reaches of unloaded trailers being towed must have and use a 1-inch pin near the end or an equally effective means to prevent pulling or stripping through the tunnel.

(2) Reach locks or tighteners must be the type that securely locks the reach in the tunnel.

(3) A reach smaller than the largest size usable in the tunnel must not be used.

(4) Trailer reach tunnels must not be altered to accommodate a smaller reach.

(5) A grab iron or an adequate handhold must be on both sides near the coupling end of trailer reaches and be in good repair.

(6) Inspect the entire length of extendable reaches monthly, including the portion that is normally in the tunnel.

(7) Bent, defective, cracked or excessively worn reaches must be removed from service.

(8) Reaches must not be welded without approval from the manufacturer.

(9) Pup trailer drawbar eyes must not be build up or rings inserted.

(10) Eyes in compensating reaches must have insert rings secured to the eyes by welding.

**Stat. Auth.:** ORS 654.025(2) and 656.726(4).  
**Stats. Implemented:** ORS 654.001 through 654.295.  
**Hist:** OR-OSHA Admin. Order 5-2003, f. 6/02/03, ef. 12/01/03.

**437-007-1045 Log Truck Trailers.**

(1) Trailer hoisting straps must:

- (a) Be fastened securely to the trailer frame.

- (b) Be used when hoisting the trailer.
  - (c) Be maintained in good condition.
  - (d) Enable the unloading machine to engage the strap without placing personnel in danger.
  - (e) Comply with the out-of-service requirements for wire rope in OAR 437-007-0605(5).
- (2) At least one binder or an equivalent method must be used to secure a trailer loaded on a truck for transport.
- (3) When unloading a trailer from a truck:
- (a) Hoist it clear.
  - (b) Drive the truck forward until clear.
  - (c) Lower the trailer to within 1-foot of the ground before approaching it.

**Stat. Auth.:** ORS 654.025(2) and 656.726(4).  
**Stats. Implemented:** ORS 654.001 through 654.295.  
**Hist:** OR-OSHA Admin. Order 5-2003, f. 6/02/03, ef. 12/01/03.

#### **437-007-1050 Log Truck and Trailer Bunks and Stakes.**

- (1) Every truck or trailer transporting logs loaded lengthwise must have bunks and bunk blocks, or stakes.
- (2) All stakes, stake extensions and bunks and their securing hardware must be designed and constructed to withstand their anticipated loads.
- (3) Defective stakes, stake extensions, bunks or means provided for securing or locking the stakes in hauling position must be removed from service.
- (4) Stakes or blocks that release must have the releasing mechanism at the opposite side of the bunk.
- (5) All swivel-type bunks must have locks or another method for keeping bunks perpendicular to the reach until the first full bunk tier of logs is loaded.
- (6) Bunk locks must be disengaged before starting to haul the load.
- (7) Bunk blocks must extend at least 8 inches above the top edge of the bunk.

# LOG TRUCK & TRAILER BUNKS & STAKES / LOG TRUCK & TRAILER BUNK CHAINS & CABLES

# K

- (8)** Bunk blocks and stakes must not extend beyond the end of the bunk.
- (9)** Stake extensions must be secured to the stake.
- (10)** Bunks or bolsters must be either straight or curve upward. Bunks with ends lower than their center must not be used.
- (11)** Log bunks on trucks and trailers must keep the logs from slipping endways.

**Stat. Auth.:** ORS 654.025(2) and 656.726(4).  
**Stats. Implemented:** ORS 654.001 through 654.295.  
**Hist:** OR-OSHA Admin. Order 5-2003, f. 6/02/03, ef. 12/01/03.

## **437-007-1055 Log Truck and Trailer Bunk Chains and Cables.**

**(1)** Chains or cables used to secure bunk blocks or stakes must have a manufacturer's rating for a safe working load of not less than 6,600 pounds. The following chain and wire rope meet the 6,600 pound requirement:

**(a)** Chain of welded link construction:

**(A)** 3/8-inch alloy steel chain, or

**(B)** 7/16-inch high-test steel chain, and

**(b)** 5/8-inch IPS wire rope in 6 x 19 or 6 x 37 construction.

**(2)** Bunk chains must be immediately removed from service when they contain cuts, cracks, other defects or when wear has reduced the original chain diameter by 15 percent.

**(3)** Wire rope used for stake straps must meet the requirements of OAR 437-007-0605(1).

**(4)** Only repair links with strength equivalent to the chain are permissible for repairs or attachments for chains.

**Stat. Auth.:** ORS 654.025(2) and 656.726(4).  
**Stats. Implemented:** ORS 654.001 through 654.295.  
**Hist:** OR-OSHA Admin. Order 5-2003, f. 6/02/03, ef. 12/01/03.

**K****ADDITIONAL REQUIREMENTS FOR  
LOG TRUCKS EQUIPPED WITH  
SELF-LOADERS**Oregon Administrative Rules  
Oregon Occupational Safety  
and Health Division**437-007-1060 Additional Requirements for Log Trucks Equipped With Self-Loaders.**

- (1) Self-loaders built for log trucks after July 1, 1980, must have a:
- (a) Load check valve (velocity fuse) or similar device on the jib boom.
  - (b) Seat offset from the point of attachment of the boom.
  - (c) Seat and boom structure that rotate concurrently.
- (2) The operators of self-loading log trucks must:
- (a) Not heel logs over their heads.
  - (b) Avoid heeling logs on the operator side of the boom.
- (3) There must be a safe and adequate means of access to and exit from the loading work station on self-loading log trucks.
- (4) A self-loading log truck must not load itself or another truck when the loading process is:
- Under or within an active spar guyline circle or similar overhead hazard.
  - Out of a deck when yarding or skidding pose a hazard to the loader operator.
- (5) When loading around powerlines the requirements of OAR 437-007-0230 must be complied with.
- (6) Self-loading log truck operators must not unload their own load unless they use a positive means of securing the logs when wrappers and binders are removed.
- NOTE: The loading boom, when placed alongside the load, may serve this purpose when no other means are available.*
- (7) Self-loading log truck operators must not operate chain saws or yard logs when working alone.
- (8) Self-loading log truck operators must comply with OAR 437-007-0210, Checking System, and 437-007-0215, Working Alone requirements.

**Stat. Auth.:** ORS 654.025(2) and 656.726(4).

**Stats. Implemented:** ORS 654.001 through 654.295.

**Hist:** OR-OSHA Admin. Order 5-2003, f. 6/02/03, ef. 12/01/03.

**TABLE OF CONTENTS**

<b>437-007-1100</b>	General Work Practices .....	L-1
<b>437-007-1105</b>	General Requirements for Log and Wood Fiber Unloading, Handling and Storage Areas.....	L-2
<b>437-007-1110</b>	Wrappers Removal General .....	L-3
<b>437-007-1115</b>	Barriers For Securing Log Loads .....	L-3
<b>437-007-1120</b>	Removing Wrappers From Barrier Secured Loads .....	L-4
<b>437-007-1125</b>	Removing Wrappers From Machine Secured Loads .....	L-4
<b>437-007-1130</b>	Removing Center Wrappers From Unsecured Loads .....	L-5
<b>437-007-1135</b>	Unloading Logs .....	L-5
<b>437-007-1140</b>	Split Loads.....	L-5
<b>437-007-1145</b>	Loading or Unloading Trailers .....	L-6
<b>437-007-1150</b>	Trailer Hoists .....	L-6
<b>437-007-1155</b>	Dry Land Log and Fiber Handling and Processing .....	L-8
<b>437-007-1160</b>	Water Dumps, Log Ponds and Booms .....	L-9
<b>437-007-1165</b>	Boats.....	L-11

<b>L</b>		Oregon Administrative Rules Oregon Occupational Safety and Health Division
----------	--	--

# GENERAL WORK PRACTICES

L

## **437-007-1100 General Work Practices.**

- (1)** It is the responsibility of the employer who has actual control of the log or wood fiber unloading, handling or storage activities to develop, post and enforce yard rules.
- (2)** Unauthorized foot and vehicle traffic is prohibited in the log or wood fiber unloading, handling or storage areas.
- (3)** No person is permitted to approach the immediate vicinity of a log or wood fiber handling machine without:
  - (a)** Notifying the operator of the intention to approach the machine, and
  - (b)** Receiving an acknowledgment from the operator.
- (4)** No person may enter the area next to a loaded log truck unless:
  - (a)** They are protected by a barrier or log handling machine, or
  - (b)** The centers of all logs are below the top of the stakes, or
  - (c)** The load is secured with tight wrapper(s).
- (5)** Unauthorized persons must not operate vehicle(s), equipment or machines in log or wood fiber unloading, handling and storage areas.
- (6)** Before starting or moving any machine, the operator must determine that no personnel are in the path of the machine.
- (7)** All persons must be in the clear and plain view of the operator before the log or wood fiber unloading machine is moved.
- (8)** Logs must not be swung over ground personnel, occupied machinery, equipment or vehicles.
- (9)** The operator's attention must not be distracted from duties while engaged in operating a log-handling machine.
- (10)** Loads on forklift-type log handling machines must be transported as low as safely operable without obstructing visibility.
- (11)** Riding on any part of a log handling machine, other than the operator's seat, is prohibited.

**Stat. Auth.:** ORS 654.025(2) and 656.726(4).

**Stats. Implemented:** ORS 654.001 through 654.295.

**Hist:** OR-OSHA Admin. Order 5-2003, f. 6/02/03, ef. 12/01/03.

<b>L</b>	<b>GENERAL REQUIREMENTS FOR LOG &amp; WOOD FIBER UNLOADING, HANDLING AND STORAGE AREAS</b>	Oregon Administrative Rules Oregon Occupational Safety and Health Division
----------	--	--

**437-007-1105 General Requirements for Log and Wood Fiber Unloading, Handling and Storage Areas.**

- (1) It is the responsibility of the employer who has actual control of the log or wood fiber unloading, handling operations or storage activities to insure that road beds are:
- (a) Hard-packed material.
  - (b) Of sufficient width and evenness to provide for safe operation of vehicles and mobile machinery.
- (2) Log or wood fiber handling operations must be arranged so that ground personnel, buildings, machines and vehicles are not exposed to the hazards associated with the movement of logs and log handling machines.
- (3) A clear space, free of obstructions, not less than 10 feet wide must be maintained the length of and parallel to the log or wood fiber load on the side opposite the unloader.
- (4) Roadways and traffic lanes must be kept clear of protruding log ends and debris.
- (5) Log or wood fiber unloading, handling and storage areas must be maintained in a condition which is conducive to safe operation of mobile equipment.
- (6) Logs or wood fiber in decks or piles must be placed in a orderly manner which will eliminate as far as possible the hazards from rolling or shifting logs.
- (7) Do not allow bark, chunks, mud and other debris to accumulate enough to become a hazard.
- (8) The employer must implement an effective method to control dust at log unloading, handling and storage areas.
- (9) All forklift-type log handling machines must be equipped with a grapple system and the arms must be closed whenever logs or wood fiber are being carried.

**Stat. Auth.:** ORS 654.025(2) and 656.726(4).

**Stats. Implemented:** ORS 654.001 through 654.295.

**Hist:** OR-OSHA Admin. Order 5-2003, f. 6/02/03, ef. 12/01/03.

**437-007-1110 Wrappers Removal General.**

- (1) Yard rules for removing wrappers, binders and loads must be posted.
- (2) Loads with logs or wood fiber above the stakes must be secured before all wrappers and binders are removed.
- (3) Personnel must inspect log or wood fiber loads for potential hazards that could be created when binders are released and wrappers are removed.
- (4) An extra wrapper or metal band of equal strength must be in place to hold the logs or wood fiber in place when it becomes necessary to remove a wrapper from fouled or dislodged logs.
- (5) Wrappers must not be removed at weigh stations or other points of transit unless requirements for securing loads are met.

**Stat. Auth.:** ORS 654.025(2) and 656.726(4).

**Stats. Implemented:** ORS 654.001 through 654.295.

**Hist:** OR-OSHA Admin. Order 5-2003, f. 6/02/03, ef. 12/01/03.

**437-007-1115 Barriers For Securing Log Loads.**

- (1) Barriers used to secure loads must:
  - (a) Be at least 15 feet high.
  - (b) Be designed to prevent logs from striking personnel while binders and wrappers are removed.
  - (c) Have the barrier controls, if any, on the release side of the unloading station and forward of the truck cab guard.
- (2) Barriers and the area surrounding the barrier structure must be free of accumulations of bark, mud and other debris.

**Stat. Auth.:** ORS 654.025(2) and 656.726(4).

**Stats. Implemented:** ORS 654.001 through 654.295.

**Hist:** OR-OSHA Admin. Order 5-2003, f. 6/02/03, ef. 12/01/03.

OR-OSHA Admin. Order 2-2005, f. 5/27/05, ef. 6/1/05.

<b>L</b>	<b>REMOVING WRAPPERS FROM BARRIER SECURED LOADS / REMOVING WRAPPERS FROM MACHINE SECURED LOADS</b>	Oregon Administrative Rules Oregon Occupational Safety and Health Division
----------	--	--

**437-007-1120 Removing Wrappers From Barrier Secured Loads.**

**(1)** Any person releasing binders and removing wrappers at a barrier, must not extend their upper body beyond the front of the protective structures.

**(2)** After binders and wrappers have been removed at a barrier, loaded log or wood fiber trucks must not move through areas where ground personnel are present unless:

**(a)** The centers of all logs are below the top of the stakes, or

**(b)** Ground personnel and machines are not exposed to the hazard of falling logs or wood fiber.

**Stat. Auth.:** ORS 654.025(2) and 656.726(4).

**Stats. Implemented:** ORS 654.001 through 654.295.

**Hist:** OR-OSHA Admin. Order 5-2003, f. 6/02/03, ef. 12/01/03.

**437-007-1125 Removing Wrappers From Machine Secured Loads.**

**(1)** When a log handling machine is used to secure a load, binders should be released and wrappers removed from the side of the load on which the unloader operates.

**(2)** If binders and wrappers must be removed from log loads on the side opposite the unloading machine, all logs must be secured from displacement before binders and wrappers are removed.

**(3)** Any person removing binders and wrappers must be in the clear and in full view of the unloading operator before giving a signal to move the unloading machine or the load of logs.

**Stat. Auth.:** ORS 654.025(2) and 656.726(4).

**Stats. Implemented:** ORS 654.001 through 654.295.

**Hist:** OR-OSHA Admin. Order 5-2003, f. 6/02/03, ef. 12/01/03.

## REMOVING CENTER WRAPPERS FROM UNSECURED LOADS / UNLOADING LOGS / SPLIT LOADS

L

**437-007-1130 Removing Center Wrappers From Unsecured Loads.** When any binder and wrapper is removed before a log load is secured by a barrier or log handling machine:

(1) There must not be double-ended logs loaded above the stakes on the side of the load from which the binders and wrappers are being released.

(2) All short logs (27 feet or less) above the stakes or bunk blocks must be secured by a minimum of one tight binder and wrapper prior to the placement of the unloading grapple arms.

(3) All long logs (more than 27 feet) above the stakes or bunk blocks must be secured by a minimum of two tight binders and wrappers prior to the placement of the unloading grapple arms.

**NOTE:** The wrappers nearest the truck and trailer bunks should be retained to allow clearance for the unloading device.

(4) The remaining binders and wrappers must not be removed before the load is secured by a barrier or log handling machine.

**Stat. Auth.:** ORS 654.025(2) and 656.726(4).

**Stats. Implemented:** ORS 654.001 through 654.295.

**Hist:** OR-OSHA Admin. Order 5-2003, f. 6/02/03, ef. 12/01/03.

### **437-007-1135 Unloading Logs.**

(1) The truck driver must be in front of the truck or in the truck cab when logs are unloaded.

(2) When logs are unloaded, the loads must not be passed over the truck cab or personnel.

**Stat. Auth.:** ORS 654.025(2) and 656.726(4).

**Stats. Implemented:** ORS 654.001 through 654.295.

**Hist:** OR-OSHA Admin. Order 5-2003, f. 6/02/03, ef. 12/01/03.

**437-007-1140 Split Loads.** When logs are to be unloaded at different destinations within the log handling or storage areas, vehicles must not be moved after each partial unloading until the requirements for securing loads are met unless:

(1) The centers of all logs are below the top of the stakes, or

(2) There are no ground personnel and machines exposed to the hazard of falling logs.

**Stat. Auth.:** ORS 654.025(2) and 656.726(4).

**Stats. Implemented:** ORS 654.001 through 654.295.

**Hist:** OR-OSHA Admin. Order 5-2003, f. 6/02/03, ef. 12/01/03.

**L****LOADING OR UNLOADING TRAILERS /  
TRAILER HOISTS**Oregon Administrative Rules  
Oregon Occupational Safety  
and Health Division**437-007-1145 Loading or Unloading Trailers.**

(1) When forklift-type machines are used to load, unload, or handle trailers, a secure means of holding the lifting attachment on the fork must be installed and used.

(2) When trailers are to be loaded after dark, sufficient lights must be provided for a safe operation.

**Stat. Auth.:** ORS 654.025(2) and 656.726(4).

**Stats. Implemented:** ORS 654.001 through 654.295.

**Hist:** OR-OSHA Admin. Order 5-2003, f. 6/02/03, ef. 12/01/03.

**437-007-1150 Trailer Hoists.**

(1) All trailer loading devices must be designed, constructed and maintained so as to have a five-to-one safety factor for the rated load capacity.

(2) Trailer loading hoists must be high and wide enough so they can safely load the maximum-sized trailers they are expected to handle without hanging up or striking the equipment.

(3) Trailer-loading-hoist controls (buttons) must have clear marking to indicating the “up” and “down” directions of travel.

(4) Trailer loading hoists must have an upper limit switch installed and maintained to prevent the hook or other end fittings from contacting the upper sheaves. In addition:

(a) The upper limit switch must not be used as an operating control.

(b) If the upper limit switch does not function properly, the hoist must not be used until repairs are made.

(5) Electric-powered trailer loading hoist controls (buttons) connected to flexible cords (pendant lines) must be secured with devices or fittings that prevents pull from being directly transmitted to joints or terminal screws.

(6) Pendants must be installed so that the control switch does not touch the ground when retracted.

(7) All electrical equipment must be weatherproof-type or adequately protected from the weather, and must meet or exceed the requirements of the National Electrical Code.

**(8)** Electric-powered hoists using handheld cord remote controls in grounded locations must be actuated by circuits operating at less than 50 volts to ground.

**(9)** Trailer loading hoists, except A-frames or bridge cranes, must be equipped with reach guides or devices that will keep the reach in proper alignment.

**(10)** A tag rope or other safe guidance device must be used to guide trailers being loaded by A-frame loaders.

**(11)** The maximum capacity that can be lifted by the trailer loader hoist must be posted in a conspicuous location where it can be easily seen by any person operating the hoist.

**(12)** Trailer loading hoists must be inspected at least every 30 days and must be maintained in good repair.

**(13)** A written trailer loading hoist inspection report signed by the person making the inspection must be kept on file by the company for 12 months.

**(14)** The employer must do an annual lifting test on each loading device and keep a written record of the tests.

**(a)** The written record must contain the:

**(A)** Date of the test.

**(B)** Name of person conducting the test.

**(C)** Amount of weight lifted.

**(b)** The written record of test results must be kept in the office of the employer or at the site.

**(c)** The test weight must not be:

**(A)** Less than 125 percent of the maximum rated load.

**(B)** More than 130 percent of the maximum rated load.

**(15)** Each trailer loading hoist drum must be designed and arranged so the hoisting line will maintain lead and spool evenly without chafing, crossing, or kinking.

**(16)** A braking system must be installed on trailer loading hoists that has the ability to safely brake and hold 1 1/2 times the weight of the full rated load.

**Stat. Auth.:** ORS 654.025(2) and 656.726(4).

**Stats. Implemented:** ORS 654.001 through 654.295.

**Hist:** OR-OSHA Admin. Order 5-2003, f. 6/02/03, ef. 12/01/03.

**437-007-1155 Dry Land Log and Fiber Handling and Processing.**

- (1) Identification tags must not be applied or pulled unless logs are resting in a stationary place, such as bunks, cradles, skids, or sorting tables.
- (2) When personnel are required to work on logs unloaded onto skids (bay logs), sufficient space must be maintained between the top of the skids (bay logs) and the ground or deck so logs will clear the prone body of a person.
- (3) Logs placed onto skids (bay logs) for processing must be laid out so that the person bucking them has enough room to operate the chain saw safely. The diameter of the logs must be taken into consideration.
- (4) Logs placed in bays or onto skids (bay logs) for processing or scaling must not be moved until the ground personnel have finished their tasks, or unless ground personnel request assistance to move a log to complete the task (i.e., extracting a pinched saw).
- (5) Machines and ground personnel must not enter the swing radius of a machine without permission of the operator. The swing radius is determined by combining the working radius of the machine and the length of logs being handled.
- (6) Ground personnel must not walk or work behind front-end loaders and forklift-type log handling machines without contacting the operator.
- (7) Log handling machines must not carry logs over an active processing bay.
- (8) Loads on forklift-type log handling machines must be transported as low as safely operable without obstructing visibility.
- (9) The requirements of OAR 437, Division 2/N, Materials Handling and Storage, apply to Overhead and Gantry Cranes used to unload, process and deck logs.

**Stat. Auth.:** ORS 654.025(2) and 656.726(4).

**Stats. Implemented:** ORS 654.001 through 654.295.

**Hist:** OR-OSHA Admin. Order 5-2003, f. 6/02/03, ef. 12/01/03.

### **437-007-1160 Water Dumps, Log Ponds and Booms.**

- (1)** A minimum of two people must work at water dumps when logs are being unloaded. At least one person must be an experienced unloading machine operator.
- (2)** At least two people must be present for stowing, sorting or boom work of any kind except when one person is feeding the slip (hot lane) from a designated area.
- (3)** All water dumps must have brow logs except when logs are lifted from the truck or rail car.
- (4)** If mobile log handling machines are used to dump loads, adequate stops must be provided to prevent the machines from running off the edge of the dump.
- (5)** When a brow log is used with a parbuckle system, all personnel are prohibited from going between the brow log and the load of logs at any time.
- (6)** Unloading lines must be arranged so that it is not necessary for a person to attach them on the water or dump side of the load.
- (7)** The unloading machine operator must:
  - (a)** Have an unobstructed view of the dump and the logs being unloaded; or
  - (b)** Receive a signal before dumping the logs.
- (8)** All personnel must be in the clear and a signal given before logs are dumped.
- (9)** When dry land log dumps use unloading methods similar to those of water dumps, OAR 437-007-1160(5) through (8) will apply.
- (10)** All personnel working on logs or around boom sticks in water must wear sharp-caulked shoes or slip-on sharp-caulked shoes.
- (11)** Metal or conductive pike poles must not be used around exposed electrical conductors.
- (12)** Defective poles, blunt or dull pikes must not be used.
- (13)** Sufficient walkways and floats must be installed and securely anchored to provide safe passage for personnel.
- (14)** Decks, floats or other walkways must be kept above the waterline at all times, and they must be capable of supporting four times the imposed load.

**L****WATER DUMPS, LOG PONDS & BOOMS**Oregon Administrative Rules  
Oregon Occupational Safety  
and Health Division

**(15)** Pond rafts must be removed from service when they are no longer capable of remaining above water while supporting a 500-pound load on any edge.

**(16)** All regular boom sticks and foot logs must be:

- (a)** Reasonably straight, free of protruding knots and have the bark removed, and
- (b)** Capable of supporting any necessary weight of personnel and equipment above the waterline at either end.

**(17)** Gaps between ends of boom sticks must not exceed 24 inches.

**(18)** All wire must be removed from booms and chains before they are reused or hung in rafting stalls.

**(19)** Permanent cable swifters must be arranged so it will not be necessary to roll boom sticks in order to attach or detach them.

**(20)** When cable swifters or dogging lines become hazardous from an excessive amount of jagers, they must be discarded.

**(21)** Stiff booms must be constructed of not less than two float logs or equivalent timbers and must have a minimum width of 36 inches.

**(22)** Float logs or equivalent timbers must be securely joined together by not less than 4-inch by 6-inch cross ties.

**(23)** Stiff booms must be planked over with not less than 2-inch planking, securely fastened and kept in good repair, at all sorting gaps or locations where mechanical devices are operated.

**(24)** Walkways along sorting gaps must be at least 4 feet wide. Other planked walkways must be at least 22 inches wide.

**(25)** Life rings attached to 90 feet of 1/4-inch line with a minimum breaking strength of 500 pounds, must be provided at convenient points adjacent to water that is 5 feet or more in depth.

**(26)** Life rings must have a minimum of 30 inches outside diameter and 17 inches inside diameter.

**(27)** Life rings must be maintained so as to retain a 32-pound positive buoyancy.

**Stat. Auth.:** ORS 654.025(2) and 656.726(4).

**Stats. Implemented:** ORS 654.001 through 654.295.

**Hist:** OR-OSHA Admin. Order 5-2003, f. 6/02/03, ef. 12/01/03.

## **437-007-1165 Boats.**

- (1)** Gasoline-powered inboard motorboats must be equipped with a mechanical exhaust system for ventilating the engine compartment and bilges.
- (2)** Mechanical exhaust systems must be powered by non-sparking fans or the fan motor must be located outside the bilge and engine compartment.
- (3)** Gasoline-powered inboard motorboats must not be started until the bilges and engine compartment have been mechanically vented of combustible fumes that may have accumulated.
- (4)** Decks of boats must be covered with a slip-resistant material.
- (5)** Boats must be provided with:
  - (a)** At least one 3A-40B:C fire extinguisher.
  - (b)** A life ring or equivalent with line attached.

**EXCEPTION:** A life ring is not required on small pond boats designed to transport only one employee.

**Stat. Auth.:** ORS 654.025(2) and 656.726(4).

**Stats. Implemented:** ORS 654.001 through 654.295.

**Hist:** OR-OSHA Admin. Order 5-2003, f. 6/02/03, ef. 12/01/03.

<b>L</b>		Oregon Administrative Rules Oregon Occupational Safety and Health Division
----------	--	--

# AIRCRAFT USED IN FOREST ACTIVITIES

# M

## TABLE OF CONTENTS

<b>437-007-1200</b>	Helicopter Operation .....	M-1
<b>437-007-1205</b>	Aircraft Refueling/Maintenance Area .....	M-3

**M**

Oregon Administrative Rules  
Oregon Occupational Safety  
and Health Division

## **437-007-1200 Helicopter Operation.**

- (1)** Prior to daily operations, a briefing must be conducted. This briefing must set forth the plan of operation for the pilot(s) and ground personnel. Anytime a change in operating procedure is necessary, affected personnel must be notified in advance.
- (2)** There must be reliable radio communications available between the helicopter service areas, woods, landing and ground crews. In the absence of radio communication there must be a designated signal person.
- (3)** Personnel must get the pilot's attention and permission before approaching a helicopter that has the rotor blades turning.
- (4)** When approaching or leaving a helicopter that has the rotor blades turning, personnel must follow the specific company procedures established for the type and make of aircraft.
- (5)** Personnel must wear high-visibility hard hats. When personnel are exposed to rotor wash, the hard hats must be secured by a chin strap.
- (6)** Personnel are not required to wear hard hats when:
  - (a)** Working in helicopter service areas to perform activities, such as refueling or maintenance.
  - (b)** Filling buckets from dip-tanks or tankers.
  - (c)** Loading seed, fertilizer or chemicals.
- (7)** The flagging and signing requirements of OAR 437-007-0510 and 437-007-0515 must be complied with when the helicopter flight path crosses a road(s).
- (8)** Riding the hook of a helicopter is prohibited, except in a life-threatening emergency.
- (9)** The drop zone must be large enough for the load(s) to be landed without endangering the landing crew.
- (10)** The landing crew must be in the clear until the:
  - (a)** Load is placed on the ground.
  - (b)** Chokers are released from the hook.
- (11)** The landing must be kept as free of debris as possible.
- (12)** Before any load is moved, personnel must be in the clear.

# M

## HELICOPTER OPERATION

Oregon Administrative Rules  
Oregon Occupational Safety  
and Health Division

**(13)** When the helicopter is carrying a load or chokers, personnel must remain in the clear. Under no circumstances may personnel and occupied machines or vehicles be under a suspended load.

**(14)** If ground personnel need to lighten a load, they must remain in the clear until the load is stabilized.

**(15)** If a load must be aborted or lightened by the pilot, ground personnel must be in the clear before the pilot releases the hook.

**(16)** The yarding helicopter must be equipped with a siren to warn personnel of any hazardous situation.

**Stat. Auth.:** ORS 654.025(2) and 656.726(4).

**Stats. Implemented:** ORS 654.001 through 654.295.

**Hist:** OR-OSHA Admin. Order 5-2003, f. 6/02/03, ef. 12/01/03.

# AIRCRAFT REFUELING/ MAINTENANCE AREA

# M

## 437-007-1205 Aircraft Refueling/Maintenance Area.

- (1) The helicopter refueling and maintenance area must be located so personnel are not exposed to the hazards created by yarding and log handling activities.
- (2) Unauthorized personnel are not allowed to be within 50 feet of an active refueling operation or fueling equipment.
- (3) The refueling area must be posted with “NO SMOKING” signs.
- (4) The following are prohibited within 50 feet of the refueling area or refueling equipment:
  - (a) Smoking.
  - (b) Open flames.
  - (c) Exposed flame heaters.
  - (d) Flare pots.
  - (e) Open flame lights.
  - (f) Operating pre-heaters.
- (5) At least one or a combination of portable fire extinguishers must be provided for each refueling and maintenance area. The minimum ratings of portable fire extinguishers must be equivalent to:

Category	Helicopter Overall Length	Minimum Combined Rating
H-1	Up to but not including 50 ft.	4A-60B:C
H-2	From 50 ft. up to, but not including, 80 ft.	20A-120B:C
H-3	From 80 ft. up to, but not including, 120 ft.	40A-240B:C

**NOTE:** Helicopter overall length, includes the tail boom and the rotors fully extended.

- (6) Personnel in the refueling area must be trained to effectively use fire extinguishers.
- (7) All refueling personnel must be knowledgeable about the specific procedure to be followed for the aircraft being fueled.
- (8) Before starting the refueling operation:
  - (a) Refueling equipment and the refueling nozzle must be electrically bonded to the helicopter.

**M****AIRCRAFT REFUELING/  
MAINTENANCE AREA**Oregon Administrative Rules  
Oregon Occupational Safety  
and Health Division

**(b)** All bonding connections must be electrically and mechanically firm to clean unpainted metal parts.

*NOTE: The use of conductive hose is not acceptable to accomplish this bonding.*

**(9)** Helicopters using Jet A type fuel may be fueled with the engine(s) running.

**(10)** Helicopters using Jet B type fuel or aviation gasoline must not be fueled with the engine(s) running.

**(11)** To control spills:

**(a)** Self-closing nozzles or deadman controls must be used and they must not be blocked open.

**(b)** Nozzles must not be dragged along the ground.

**(c)** Pouring or gravity flow of fuel is not permitted from containers with a capacity of more than 5 gallons.

**(12)** When a spill creates a fire hazard, the refueling operation must be immediately stopped until a competent or authorized person determines that it is safe to resume the refueling operation.

**Stat. Auth.:** ORS 654.025(2) and 656.726(4).

**Stats. Implemented:** ORS 654.001 through 654.295.

**Hist:** OR-OSHA Admin. Order 5-2003, f. 6/02/03, ef. 12/01/03.

# WILDLAND FIRE SUPPRESSION AND PRESCRIBED FIRE

# N

## TABLE OF CONTENTS

<b>437-007-1300</b>	Purpose of Rules.....	N-1
<b>437-007-1303</b>	Application of Rules.....	N-1
<b>437-007-1305</b>	General Requirements .....	N-2
<b>437-007-1310</b>	Personnel Assignments .....	N-3
<b>437-007-1315</b>	Single Personnel Assignments .....	N-3
<b>437-007-1320</b>	Personal Protective Equipment.....	N-4
<b>437-007-1325</b>	Training.....	N-5
<b>437-007-1330</b>	Equipment, Vehicles, and Machines, General Requirements .....	N-7
<b>437-007-1335</b>	Vehicle Operation .....	N-7
<b>437-007-1340</b>	Machine Operation .....	N-8
<b>437-007-1345</b>	Helicopter Operations.....	N-9



**437-007-1300 Scope of Rules.**

(1) The purpose of the rules in Subdivision N is to provide minimum safety and health requirements for all public and private employers who engage in wildland fire prevention, wildland fire suppression or prescribed fire that includes activities such as, but not limited to:

- Fire line construction
- Engine (fire truck) operation
- Dozer, skidgine and pumper-cat operation
- Snag felling
- Fire detection
- Forest patrols
- Helicopter operation
- Slash burning
- Mop-up
- Laying hose lines
- Tending dip-tanks
- Handling, mixing and applying fire suppression chemicals

**Stat. Auth.:** ORS 654.025(2) and 656.726(4).

**Stats. Implemented:** ORS 654.001 through 654.295.

**Hist:** OR-OSHA Admin. Order 2-2005, f. 5/27/05, ef. 6/1/05.

**437-007-1303 Application of Rules.**

(1) Except as otherwise specified, the rules in Subdivision N apply to all personnel engaged in wildland fire prevention, wildland fire suppression or prescribed fire activities when there is potential for exposure to wildland fire hazards such as, but not limited to:

- Burn injuries
- Burning embers
- Extreme fire behavior
- Entrapment
- Falling snags
- Heat exhaustion
- Heat stroke
- Rolling materials
- Smoke inhalation
- Vehicle and machine operation

(2) The rules in Subdivision N do not limit the use of other applicable safety and health rules.

(3) The rules in Subdivision N do not apply to personnel assigned to wildland fire suppression support activities, such as fire camp support positions which will not expose them to wildland fire hazards.

**Stat. Auth.:** ORS 654.025(2) and 656.726(4).

**Stats. Implemented:** ORS 654.001 through 654.295.

**Hist:** OR-OSHA Admin. Order 2-2005, f. 5/27/05, ef. 6/1/05.

**437-007-1305 General Requirements.**

(1) Tactical and command fire suppression communications must provide a clear line of communication to all affected personnel.

**NOTE:** A competent person may make single employee assignments as long as the requirements of OAR 437-007-0200(3) Site Planning and Implementation, OAR 437-007-0210(2)(a) through (c) Checking System, and OAR 437-007-0215(1) Working Alone, are complied with. These rules are reprinted below.

OAR 437-007-0200(3) Workers must be placed and their activities arranged so they are in the clear and the actions of one worker will not create a hazard for any other worker(s).

OAR 437-007-0210(2) The employer must implement a system to check the well-being of those workers whose jobs may be single employee assignments, as provided for in OAR 437-007-0215(3). The system must include:

- (a) The time interval between checks and the procedures to be followed if the employee cannot be contacted, including provisions for emergency medical care and treatment.
- (b) A specific person must be assigned for:
  - (A) Contacting the lone employee.
  - (B) Verifying when contacts were made.
- (c) The time intervals for checking the single employee's well-being must be understood and agreed to by all parties. Intervals should reflect the hazardous nature of the work and the methods available for checking.

OAR 437-007-0215(1) The employer must not assign workers to a task or location so isolated as to be without visual, audible, or radio contact with another person who can summon or provide aid in an emergency.

(2) When employees are required to handle, mix and/or apply hazardous chemicals, the employer must develop, implement and maintain a written hazard communication program meeting the requirements of Division 2, Subdivision 2/Z, Toxic and Hazardous Substances, 1910.1200, Hazard Communication.

(3) During the initial attack on a wildland fire, when the fire and/or the fire suppression activity creates a hazardous condition for traffic and warning signs and/or flaggers are not controlling traffic, a vehicle with emergency flashing lights must be used to warn traffic.

**NOTE:** See Division 7 Subdivision F, 437-007-0510 Roads, Vehicles, Flagging and Flammables.

**Stat. Auth.:** ORS 654.025(2) and 656.726(4).

**Stats. Implemented:** ORS 654.001 through 654.295.

**Hist:** OR-OSHA Admin. Order 2-2005, f. 5/27/05, ef. 6/1/05.

**437-007-1310 Personnel Assignments.**

(1) The employer and/or their authorized representative must take into account the physical capability of each employee to safely perform assigned tasks:

- (a) Prior to job assignment, and
- (b) While the employee performs those tasks.

(2) Personnel performing wildland fire suppression or prescribed fire activities except as provided for in OAR 437-007-1315(1) and (2), must:

- (a) Work in teams of two or more, and
- (b) Be positioned so they are close enough to render assistance to one another in case of an emergency.

**NOTE:** This rule does not prohibit the ignition and monitoring of burn piles and landings by one employee when a competent person has determined that conditions are such that the fire(s) will not spread beyond the fuels intended to be burned.

**Stat. Auth.:** ORS 654.025(2) and 656.726(4).

**Stats. Implemented:** ORS 654.001 through 654.295.

**Hist:** OR-OSHA Admin. Order 2-2005, f. 5/27/05, ef. 6/1/05.

**437-007-1315 Single Personnel Assignments.**

(1) Single employee assignments such as watchers, security and forest patrol personnel may take appropriate action to contain, control or extinguish a fire upon discovery only when:

- (a) They have first reported the fire, described their intended fire suppression activities, and agreed on a checking system as required by OAR 437-007-0210; and
- (b) Their fire suppression activities are consistent with firefighter training and safety; and
- (c) There is an escape route to a safety zone that will not be cut off if the fire increases in size or changes direction.

(2) A competent person must ensure that watchers, security and forest patrol personnel, and other single employee assignment personnel who are expected to perform fire suppression activities:

- (a) Have received Basic Wildland Fire Safety Training as required by OAR 437-007-1325; and
- (b) Are qualified in the operation of assigned fire suppression machines, equipment, and use of fire fighting tools; and

**N****SINGLE PERSONNEL ASSIGNMENTS /  
PERSONAL PROTECTIVE EQUIPMENT**Oregon Administrative Rules  
Oregon Occupational Safety  
and Health Division

(c) Are advised of the requirements of OAR 437-007-1315(1) and other job site conditions, known by the employer, which could affect the extent of their fire suppression activities; and

(d) Are physically capable of performing assigned fire suppression activities as required by OAR 437-007-1310(1).

**Stat. Auth.:** ORS 654.025(2) and 656.726(4).

**Stats. Implemented:** ORS 654.001 through 654.295.

**Hist:** OR-OSHA Admin. Order 2-2005, f. 5/27/05, ef. 6/1/05.

**437-007-1320 Personal Protective Equipment.**

(1) Personnel performing wildland fire suppression or prescribed fire activities must wear:

(a) Pants and a long-sleeved shirt made of cotton, wool, denim or other fire resistant materials.

**NOTE:** The employer is not required to provide the clothing listed in OAR 437-007-1320(1)(a).

(A) Clothing made from common permanent-press materials or synthetic fibers that melt when exposed to flame or heat must not be worn.

(B) When special protective clothing made of aramid or other fire resistant materials is required by the employer, the employer must provide it at no cost to the personnel.

(b) Footwear that:

(A) Covers and provides protection and support for the foot and ankle, such as heavy duty leather lace-up boots with an 8-inch high top.

(B) Provides for secure footing and traction for the assigned task.

**NOTE:** Caulked boots, in accordance with the requirement of OAR 437-007-0330, may be required for some fire suppression or prescribed fire duties.

(C) Is fire and melt resistant.

(D) Is made of or covered with chain saw cut resistant material when operating a chain saw.

**NOTE:** The employer is not required to provide the minimum basic footwear listed in OAR 437-007-1320(1)(b).

(c) Head protection in accordance with the requirement of OAR 437-007-0305(1) and (2).

(A) When wearing hard hats around helicopters, the hats must be secured by a chin strap.

**NOTE:** To reduce the possibility of blowing objects when working around helicopters, hard hats need not be worn when a competent person has determined there is no danger from falling or flying objects.

- (d) Upper body cover and/or hard hats of a high-visibility color in accordance with the requirement of OAR 437-007-0310.
- (e) Eye and face protection in accordance with the requirements of OAR 437-007-0315.
- (f) Hand protection in accordance with the requirements of OAR 437-007-0320(1) and (2).
- (g) Leg protection in accordance with the requirements of OAR 437-007-0325 when operating chain saws.
- (h) Hearing protection in accordance with the requirements of OAR 437-007-0335.

**Stat. Auth.:** ORS 654.025(2) and 656.726(4).

**Stats. Implemented:** ORS 654.001 through 654.295.

**Hist:** OR-OSHA Admin. Order 2-2005, f. 5/27/05, ef. 6/1/05.

**437-007-1325 Training.** The following requirements are in addition to the training requirements of OAR 437-007-0140.

(1) The employer and/or their authorized representative must ensure that all personnel who may be called upon to do wildland fire suppression and/or prescribed fire activities receive Basic Wildland Fire Safety Training as follows:

- (a) Once a year, between January 1 and the legal declaration of fire season, for personnel who are employed at the time training is presented.

**NOTE 1:** Personnel who have previously received Basic Wildland Fire Safety Training need only receive refresher training on those portions of the curriculum outlined in Appendix 7-C that are relevant to the fire suppression activities to which they may be assigned.

**NOTE 2:** Basic Wildland Fire Safety Training is not required for personnel who are assigned to fire support positions that will not expose them to wildland fire hazards.

Newly hired and/or reassigned personnel who have not received Basic Wildland Fire Safety Training must be trained within 17 days of being assigned or dispatched to wildland fire suppression or prescribed fire activities. In the interim, they may perform wildland fire suppression, or prescribed fire activities provided they work under the direct supervision of a competent person who must:

- (A) Brief personnel (prior to starting fire suppression or prescribed fire activities) about the escape route(s), safety zone(s), anticipated fire activity, and what to do if they get separated from the competent person; and

- (B) Provide continuous on-the-job supervision; and
- (C) Provide on-the-job fire safety training; and
- (D) Supervise no more than 5 untrained personnel.

**NOTE:** When an untrained runner is enroute, direct supervision may be achieved by radio contact provided there is a competent person providing direct supervision at both the pick-up and drop-off points.

**(2) Basic Wildland Fire Safety Training must:**

- (a) Be presented by a qualified person, and
- (b) Provide instruction and training on the curriculum outline in Appendix 7-C, and
- (c) Be presented in a language and manner that the employee(s) is able to understand.

**(3) The employer must keep a current written record of Basic Wildland Fire Safety Training for each employee.**

**(4) Personnel who are issued fire shelters must receive instructions from a qualified person prior to issue, and at least once a year thereafter, on:**

- (a) How to inspect and care for the shelter, and
- (b) How, when and where to deploy the shelter, and
- (c) What a person needs to do in the deployed shelter.

**NOTE:** When fire shelters are required, an orderly transition for employee training must be consistent with fire suppression needs and employee safety.

**Stat. Auth.:** ORS 654.025(2) and 656.726(4).

**Stats. Implemented:** ORS 654.001 through 654.295.

**Hist:** OR-OSHA Admin. Order 2-2005, f. 5/27/05, ef. 6/1/05.

## EQUIPMENT, VEHICLES & MACHINES, GENERAL REQUIREMENTS / VEHICLE OPERATION

N

### **437-007-1330 Equipment, Vehicles and Machines, General Requirements.**

(1) Fire fighting equipment, vehicles and machines must be:

- (a) Inspected for defects prior to the start of each shift.
- (b) Maintained in accordance with the appropriate manufacturers' recommendations.

(2) Fire fighting equipment, vehicles, and machines that are defective or damaged so as to render them hazardous to operate, must be removed from service and not returned to service until repairs are completed.

(3) A safe and adequate means of access and egress such as steps, ladders, and handholds must be provided and maintained to all parts of vehicles and machines where employees must go.

(4) Machine and vehicle access must comply with the Society of Automotive Engineers' SAE J185-1988 or ISO 2867:1994, Access Systems for Off-Road Machines.

(5) An effective means of communication must be established when it is necessary for personnel to communicate with the operator of a vehicle, equipment or machine.

(6) When military vehicles are used to transport personnel, they must be equipped with standard military seating, backrests and endgates or equivalent.

**Stat. Auth.:** ORS 654.025(2) and 656.726(4).  
**Stats. Implemented:** ORS 654.001 through 654.295.  
**Hist:** OR-OSHA Admin. Order 2-2005, f. 5/27/05, ef. 6/1/05.

### **437-007-1335 Vehicle Operation.**

(1) The operation of vehicles must comply with the requirements of OAR 437-007-0520 through OAR 437-007-0570.

(2) All equipment hauled on a vehicle must be adequately secured when the vehicle is in motion.

(3) Vehicles must be brought to a full stop before personnel disembark.

**Stat. Auth.:** ORS 654.025(2) and 656.726(4).  
**Stats. Implemented:** ORS 654.001 through 654.295.  
**Hist:** OR-OSHA Admin. Order 2-2005, f. 5/27/05, ef. 6/1/05.

**437-007-1340 Machine Operation.**

(1) When machines used for fire trail construction or fire fighting are operated on slopes in excess of the limitations for machine operation as defined in OAR 437-007-0935(1) and (2), a competent person must ensure that measures are taken to provide stability such as:

- (a) Using the blade; or
- (b) Tying to stumps, anchors, or other machines; or
- (c) Using materials to limit the slope under the machine; or
- (d) Limiting the operating range of movement and/or the machine loading to maintain stability.

(2) The machine operator and a competent person must agree how to safely operate on all steep slopes taking into consideration the:

- (a) Experience of the operator.
- (b) Limitations of the machine.
- (c) The soil conditions.
- (d) Direction of travel (traveling straight up and down the slope).
- (e) Hazards of turning the machine on the slope.
- (f) Weather.
- (g) Load size.
- (h) Any other adverse condition(s).

**Stat. Auth.:** ORS 654.025(2) and 656.726(4).

**Stats. Implemented:** ORS 654.001 through 654.295.

**Hist:** OR-OSHA Admin. Order 2-2005, f. 5/27/05, ef. 6/1/05.

## **437-007-1345 Helicopter Operations.**

- (1)** Helicopter facilities must be kept clear of loose objects and unauthorized personnel.
- (2)** Personnel must not smoke within 50 feet of a helicopter, fuel storage, or fueling equipment.
- (3)** Unless authorized by the pilot or helicopter ground crew, personnel must stay at least:
  - (a)** 50 feet away from small helicopters (50 feet or less overall length), and
  - (b)** 100 feet away from large helicopters.

**NOTE:** Helicopter overall length, includes the tail boom and the rotors fully extended.
- (4)** A competent person must provide a detailed briefing on helicopter safety procedures to all passengers prior to loading.
- (5)** Personnel assigned to ride in helicopters must:
  - (a)** Be briefed in the correct approach, riding and off-loading procedures for the particular type of helicopter.
  - (b)** Follow instructions of helicopter personnel at all times when around helicopter.
  - (c)** Carry all tools at their side (not slung over their shoulder) when around helicopters.
- (6)** Unless told otherwise by a competent person, personnel must approach and leave the helicopter in full view of the pilot.
- (7)** Personnel must stay away from turning tail rotors at all times.
- (8)** Personnel must not stand directly beneath a hovering helicopter unless they have been trained or are being trained in performing sling load hookup or bucket filling operations.

**Stat. Auth.:** ORS 654.025(2) and 656.726(4).

**Stats. Implemented:** ORS 654.001 through 654.295.

**Hist:** OR-OSHA Admin. Order 2-2005, f. 5/27/05, ef. 6/1/05.



## TABLE OF CONTENTS

<b>437-007-1400</b>	Jerk Wire Whistle System .....	O-1
<b>437-007-1405</b>	Radio Signal Systems .....	O-1

**O**

Oregon Administrative Rules  
Oregon Occupational Safety  
and Health Division

# JERK WIRE WHISTLE SYSTEM / RADIO SIGNAL SYSTEMS



**437-007-1400 Jerk Wire Whistle System.** The use of a jerk wire whistle system for any type of yarding operation is prohibited.

**Stat. Auth.:** ORS 654.025(2) and 656.726(4).

**Stats. Implemented:** ORS 654.001 through 654.295.

**Hist:** OR-OSHA Admin. Order 5-2003, f. 6/02/03, ef. 12/01/03.

## **437-007-1405 Radio Signal Systems.**

**(1)** When space transmission of radio signals is used to initiate any whistle, horn, bell, or other audible signaling device, or when such transmission of radio signals is used to activate or control any machine, material-handling device or other equipment hazardous to employees, the following must apply:

**(a)** An operational whistle signal must be maintained.

**(b)** A permit assigning tone frequencies and area of use for each radio unit to be used for the control and activation of any signal, machine or equipment, must be obtained from Department of Consumer and Business Services, Oregon Occupational Safety and Health Division (Oregon OSHA), by an owner prior to placing the unit in operation. Permits must be issued on the basis of compliance with the criteria contained in Appendix 7-F.

**(c)** Radio equipment must not be used without displaying a permit as required by this rule. The permit must be prominently displayed on the receiver of the unit or on the transmitter in the yarder for radio-controlled carriages.

**(d)** Applicants for permits must submit the following information concerning the equipment to the Department of Consumer and Business Services, Oregon OSHA:

**(A)** Name and address of applicant;

**(B)** The assigned radio frequency;

**(C)** The manufacturer of the unit;

**(D)** The serial number of the receiver;

**(E)** The tone frequencies upon which the unit operates;

**(F)** The intended use or function of the unit; and

- (G)** The designated area in which the equipment will be used. (See the Radio Signal Permit Area Map in Appendix 7-F.)
- (e)** Before moving any unit from one assigned area to another, a new permit must be secured from the Department of Consumer and Business Services, Oregon OSHA. (See the Radio Signal Permit Area Map in Appendix 7-F.)
- (f)** Users shall notify the Department of Consumer and Business Services, Oregon OSHA, within 15 days after the radio signaling device is:
- (A)** Permanently retired (in what manner);
  - (B)** Sold (to whom); or
  - (C)** Stolen.
- (g)** Upon receipt and approval of a properly completed application, OR-OSHA must issue a permit within 30 days; or if OR-OSHA is unable to issue a permit within 30 days of receipt and approval of a properly completed application, the applicant must be notified of the proposed date of issuance.
- (2)** Additional systems must be certified in advance as spares, providing they are used only as replacements for malfunctioning systems during the time required to repair the original equipment.
- (3)** Each radio receiver must have its tone frequencies in hertz (cycles per second), the manufacturer's name and serial number, and the assigned radio frequency clearly and permanently indicated on the outside of the case. When the duration or width of the tone frequencies performs a function, the duration or width must also be permanently indicated on the outside of the case.
- (4)** Single tone frequency must not be used on radio equipment designed to initiate whistle or other audible signal, or to activate or control any machine, material-handling device, or other equipment hazardous to employees.
- (5)** All adjustment, repair or alteration of radio signaling devices must be done only by or under the immediate supervision and responsibility of a person holding a first or second class commercial radio operator's license (for either radio telephone or radio telegraph) issued by the Federal Communications Commission. All replacement parts must be of such quality as to cause the unit to meet the minimum performance specifications outlined in Appendix 7-F.

**(6)** At least one model of each radio system must be tested and certified that it meets or exceeds the minimum requirements for performance as specified in Appendix 7-F of this standard. This model must be a random selection from stock. A copy of such performance report must be signed by the person or persons who tested the unit and submitted to Department of Consumer and Business Services, Oregon OSHA.

**(7)** Radio-controlled devices must be tested each day before work begins. If, at any time, any part of the equipment fails to function properly, or if interference, overlap, fadeout or blackout of radio signals is encountered, the system shall not be used until the source of trouble is detected and corrected.

**(8)** Two or more whistle signal receivers on the same tone frequency is prohibited.

**Stat. Auth.:** ORS 654.025(2) and 656.726(4).

**Stats. Implemented:** ORS 654.001 through 654.295.

**Hist:** OR-OSHA Admin. Order 5-2003, f. 6/02/03, ef. 12/01/03.

**O**

Oregon Administrative Rules  
Oregon Occupational Safety  
and Health Division

## TABLE OF CONTENTS

<b>437-007-1500</b>	Tree Climbing General Requirements .....	P-1
<b>437-007-1505</b>	Climbing Equipment General Requirements .....	P-1
<b>437-007-1510</b>	Climbing Procedures General Requirements .....	P-2
<b>437-007-1515</b>	Rigging Trees for Cable Logging Systems .....	P-3
<b>437-007-1520</b>	Four Inch Tie-In Systems .....	P-3
<b>437-007-1525</b>	Belayed (Snubbing) Climbing System.....	P-4
<b>437-007-1530</b>	Three Point Climbing System.....	P-4
<b>437-007-1535</b>	Storage and Transportation of Climbing Equipment General Requirements.....	P-5



**437-007-1500 Tree Climbing General Requirements.**

(1) The employer must develop rescue procedures that include:

- (a) Adequate personnel and equipment to perform the rescue.
- (b) Training in procedures to rescue a climber from a tree.

(2) When rescuing a climber, use procedures or equipment that will:

- (a) Provide support to the climber's upper body (chest) and pelvis,
- (b) Maintain the injured climber in an up-right position during rescue.

**NOTE:** Rescues may be accomplished using standard, familiar equipment, not special gear designed solely for rescue, as long as it supports the body as stated above.

(3) When the injured climber is wearing only a climbing belt, before rescue starts, provisions must be made to prevent the climber from slipping through the climbing belt.

**NOTE:** A climbing saddle or sit harness is designed to prevent slipping.

**Stat. Auth.:** ORS 654.025(2) and 656.726(4).  
**Stats. Implemented:** ORS 654.001 through 654.295.  
**Hist:** OR-OSHA Admin. Order 3-2008, f. 3/7/08, ef. 7/1/08.

**437-007-1505 Climbing Equipment General Requirements.**

(1) Before leaving the ground, the climber must:

- (a) Visually check their climbing equipment,
- (b) Immediately remove defective or damaged climbing equipment from service.
- (c) Check hardware for secure closure before placing their weight on the lanyard or life support rope.
- (d) Tie, dress and set all climbing knots.

(2) Splices must be made according to cordage manufacturer's recommendations.

(3) Life support ropes (climbing line) that are in service must:

- (a) Be easily identifiable.
- (b) Have a minimum breaking strength of 5,400 pounds.

- (c) Be used only for climbing.
- (4) Remove life support rope from climbing service when:
  - (a) It has been subjected to a shock load.
  - (b) There is excessive wear or damage detected during inspection.
- (5) Webbing used for life support must be applied in a manner that provides a minimum breaking strength of 5,400 pounds.
- (6) Climbing hardware must have a minimum breaking strength of 5,000 pounds.
- (7) Lanyard snap hooks must be self closing and self locking.
- (8) When a cutting tool is used in a tree, the climbing rope (lanyard) must be a high-quality steel safety chain of 3/16-inch size or larger or a wire core rope.

**Stat. Auth.:** ORS 654.025(2) and 656.726(4).  
**Stats. Implemented:** ORS 654.001 through 654.295.  
**Hist:** OR-OSHA Admin. Order 3-2008, f. 3/7/08, ef. 7/1/08.

#### **437-007-1510 Climbing Procedures General Requirements.**

- (1) Before climbing a tree, assess the tree and immediate area for any potential hazards that could affect the climbing activity.
- (2) When stopping to rest or work, the climber must be secured to the tree.
- (3) When using a knot to adjust the length of a cable core lanyard, use a “cats paw” (Becket Hitch), friction hitch or mechanical friction device attached to a compatible size eye splice or D-ring of a climbing belt, saddle or harness.
- (4) Don’t use climbing belts by themselves for rappels, ascender use, or friction hitch climbing.
- (5) While climbing operations are active, personnel on the ground must be positioned where they will not be struck by falling objects.
- (6) When it is necessary for ground personnel to work directly below the climber, the climber must not be engaged in any activity where tools, rigging or other objects could be dropped or dislodged from the tree.
- (7) The climber must give warning when any equipment or material is in danger of dropping, or is to be dropped deliberately.

**Stat. Auth.:** ORS 654.025(2) and 656.726(4).  
**Stats. Implemented:** ORS 654.001 through 654.295.  
**Hist:** OR-OSHA Admin. Order 3-2008, f. 3/7/08, ef. 7/1/08.

# RIGGING TREES FOR CABLE LOGGING SYSTEMS / FOUR INCH TIE-IN SYSTEMS

P

## 437-007-1515 Rigging Trees For Cable Logging Systems.

- (1) Yarding of any type must not be conducted within reach of the tree or guylines of a tree in which a climber is working.
- (2) When machines are used to hoist rigging:
  - (a) A person must be assigned to transmit the climber's signals.
  - (b) The signal person and machine operator must not perform other duties when the climber is in the tree.
  - (c) Noisy equipment, such as power saws, tractors and other logging machines, must not be operated around the area where a climber is working when such noise will interfere with the climber's signals.
- (3) Lines attached to a tree in which a climber is working must not be moved except on a signal from the climber.
- (4) Unsecured equipment, rigging, or material must not be left in the tree.

**Stat. Auth.:** ORS 654.025(2) and 656.726(4).  
**Stats. Implemented:** ORS 654.001 through 654.295.  
**Hist:** OR-OSHA Admin. Order 3-2008, f. 3/7/08, ef. 7/1/08.

## 437-007-1520 Four Inch Tie-In Systems.

- (1) Use a belay (snubbing) system, with dynamic rope, when climbing above the 4-inch bole diameter in conifers or above the last secure tie-in point capable of providing life support in hardwoods.
- (2) Install 4-inch tie-in system protection (rigging points) at least every 3 feet along the bole or branch to limit falls to no more than 6 feet.
- (3) Climbers must not:
  - (a) Place side loads on the carabiner gate.
  - (b) Use static cordage for applications where dynamic loading could occur.

**Stat. Auth.:** ORS 654.025(2) and 656.726(4).  
**Stats. Implemented:** ORS 654.001 through 654.295.  
**Hist:** OR-OSHA Admin. Order 3-2008, f. 3/7/08, ef. 7/1/08.

**437-007-1525 Belayed (Snubbing) Climbing System.**

- (1) The belay line must be a dynamic rope with a minimum 5400 pounds breaking strength.
- (2) Do not use a body belay.
- (3) Do not use a chest harness as the tie-in point.
- (4) Follow the requirements of Appendix 7-K.

**Stat. Auth.:** ORS 654.025(2) and 656.726(4).  
**Stats. Implemented:** ORS 654.001 through 654.295.  
**Hist:** OR-OSHA Admin. Order 3-2008, f. 3/7/08, ef. 7/1/08.

**437-007-1530 Three Point Climbing System.**

- (1) Use a three-point climbing system (three-points of contact) when tree climbing.

**NOTE:** A three-point system is not required when using an approved rappel or ascender system.

- (2) While tree climbing, three-points of contact must be firmly in place on a secure surface before moving to another point.

**NOTE 1:** Each hand and foot (or climbing spur) is considered a potential point of contact.

**NOTE 2:** Other parts of the body, such as a hooked knee or armpit, may be considered contact points if the body part is physically capable of supporting the full body weight.

**NOTE 3:** A lanyard around the tree bole or appropriate limb that is secured to the safety harness or climbing belt on both ends counts as two points of contact.

- (3) Do not use unsound branches or stubs for support.
- (4) Climbing without being secured to the tree is not allowed except in conifers when, in the judgment of the qualified climber, the density of branches growing from the stem would require so many limb-overs, attaching and reattaching the lanyard, as to become a greater hazard than simply climbing that section of the tree.
- (5) Climbing in conifers without being secured is not allowed above the 4-inch bole diameter.

**Stat. Auth.:** ORS 654.025(2) and 656.726(4).  
**Stats. Implemented:** ORS 654.001 through 654.295.  
**Hist:** OR-OSHA Admin. Order 3-2008, f. 3/7/08, ef. 7/1/08.

# STORAGE & TRANSPORTATION OF CLIMBING EQUIPMENT GENERAL REQUIREMENTS

P

**437-007-1535 Storage and Transportation of Climbing Equipment General Requirements.** Do not store or transport climbing equipment:

- (1) Near extreme heat sources.
- (2) In contact with gas, oil, chemicals, chemical vapors, battery and other acids.
- (3) In contact with sharp or pointed objects and other items that can damage the climbing gear.

**Stat. Auth.:** ORS 654.025(2) and 656.726(4).

**Stats. Implemented:** ORS 654.001 through 654.295.

**Hist:** OR-OSHA Admin. Order 3-2008, f. 3/7/08, ef. 7/1/08.

**P**

Oregon Administrative Rules  
Oregon Occupational Safety  
and Health Division

## Appendix 7-A (Mandatory)

### Standard Yarding System Whistle Signals

#### High Lead Whistle Signals – Means longer spacing between signals

1 short	Stop all lines.
3 short - 3 short	Ahead easy on mainline.
3 short	Ahead on mainline.
2 short	Ahead on haulback.
2 short - 2 short	Ahead easy on haulback.
3 short - 1 short	Ahead on haywire.
3 short - 1 short - 3 short	Ahead easy on haywire.
4 short or more	Slack mainline.
2 short - 1 short	Slack haulback.
3 short - 1 short - 4 short	Slack haywire.
3 short - 2 short	Standing tight line.
2 short	Tightline while lines are running, or break tightline if lines are running tight.
3 short	When rigging is in: Haywire back on haulback
3 short - plus "X" number of shorts	When rigging is in: Indicates number of sections of haywire back on rigging.
3 short - 2 short	When rigging is in: Haywire back on rigging.
1 short	When rigging is in: Chaser inspect and repair rigging.
2 short	When rigging is in: No chokers back.
2 short -1 short - plus "X" number of shorts	When rigging is in: Number of chokers back.
2 short - 1 short	When rigging is in: Slack haulback, hold all lines until 2 short blown.
3 medium	Hooker.
3 medium - 4 short	Hooker and the crew.
5 long	Climber.
4 long	Foremen.
1 long - 1 short	Start or stop work.
7 long - 2 short	Person injured, call transportation and stretcher.
1 long - 1 short	Fire.
3 short - 1 short	Acknowledge by engineer to signify a hazardous turn.

#### Grabinski system

2 short - 1 long	Slack mainline and haulback together.
2 long	Take off or put on rider block.

## Appendix 7-A (Mandatory)

### Standard Yarding System Whistle Signals

#### Slackline Whistle Signals – Means longer spacing between signals

2 short - 2 short - 2 short 1 short	First cable up when road has been changed and tail hold made fast.
2 short - 2 short - 2 short	Drop Skyline.
1 short	Stop any moving line.
1 long	When logging, slack skyline.
2 short	Ahead on skyline.
1 long - 2 short	Ahead easy on skyline.
3 short	Ahead on skidding line.
3 short - 3 short	Ahead easy on skidding line with slack haulback.
4 short	Slack skidding line.
2 short - 2 short - 2 short -2 short	Ahead easy on haulback with slack skidding line.
2 short - 2 short	Ahead on haulback.
2 short - 1 short	Slack haulback
2 short - 3 short	Pick up skyline and skid.
2 short - 2 short - 2 short	Pick up skyline and skin.
3 short	When carriage in: Haywire back on haulback.
3 short - 1 short - 2 short	When carriage in: Haywire back on carriage.
3 short - 1 short	When haywire out: Ahead on haywire.
3 short - 2 short	Tight line.
3 short - 1 short - 4 short	Slack haywire.
3 short - 1 short - 3 short	Ahead easy on haywire.
2 long	Ahead on transfer.
2 long - 4 short	Slack transfer.
2 long - 2 short - 2 short	When carriage is in: Transfer back on carriage.
3 short - plus "X" number of short	When carriage is in: Number Section back on carriage.
2 short - plus "X" number of short	When carriage is in: Number of chokers.
1 short	When carriage is in: Inspect rigging, repair and send back.
2 short - 1 short	When carriage is in: Slack haulback and hold all lines until 2 short are blown-then send back.
3 short - 3 short	When carriage is in: Send back powder.
5 medium	Tail rigger.
5 medium - 4 short	Tail rigger and that crew.
3 medium	Head hooker.
3 medium - 4 short	Second hooker and that crew
5 long	Climber.
4 long	Foreman.
1 long - 1 short	Start or stop work.
7 long - 2 short	Person injured, call transportation and stretcher.
1 long - 1 short repeated	Fire.

## Appendix 7-A (Mandatory)

### Standard Yarding System Whistle Signals

#### Running Skyline Whistle Signals – Means longer spacing between signals

1 short	Stop all moving lines.
2 short	Skin carriage back.
2 short - 1 short	Slack haulback.
2 short - 2 short	Skin carriage easy.
2 short - 3 short	Standing tight line.
1 short - 2 short	Ahead on dropline.
4 short	Slack dropline.
1 short - 4 short	Slack both mainlines.
1 short - 1 short	Stop dropline going up and move carriage forward.
3 short	Move carriage forward.
3 short - 2 short - 3 short	Move carriage forward easy.
3 short - 1 short	When haywire is out: Ahead on haywire.
3 short - 1 short - 4 short	Slack haywire.
3 short	When carriage is in: Haywire.
3 short - plus "X" number of short	When carriage is in: Number of sections.
3 short - 1 short - 2 short	When carriage is in: Haywire back on carriage.
2 short - plus "X" number of short	When carriage is in: Number of chokers.
4 short	When carriage is in: Inspect rigging, repair and send back.
1 short	When carriage is in: Hold all lines until 2 shorts, then send back
3 medium	Hooker.
3 medium - 4 short	Hooker and crew.
5 long	Climber.
4 long	Foreman.
1 long - 1 short	Start or stop work.
7 long - 2 short	Person injured, call transportation and stretcher.
1 long - 1 short repeated	Fire.
3 short - 1 long	Acknowledged by engineer to signify hazardous turn.

## Appendix 7-A (Mandatory)

### Standard Yarding System Whistle Signals

#### Tension System Whistle Signals – Means longer spacing between signals

4 short	Release tension.
1 short	Stop carriage and start unspooling tong line.
1 short	Stop tong line.
1 short	Resume unspooling tong line.
1 short	Will stop any moving line or slack tong line when carriage is stopped.
2 short - 2 short	Go into interlock and go back.
2 short - 4 short	Slack haulback and let carriage down.
After turn is set - 2 short	Go ahead on tong line.
2 short - 3 short	Go ahead easy on tong line.
3 short	Go into interlock and take carriage to landing.
3 short - 3 short	Ahead easy on carriage.
1 short - 2 short	Increase tension on tong line when carriage is going in.
1 short - 1 short	Decrease tension on tong line when carriage is going in.
3 medium	Hooker.
3 medium - 4 short	Hooker and crew.
5 long	Climber.
4 long	Foreman.
1 long - 1 short	Start or stop work.
7 long - 2 short	Person injured, call transportation and stretcher.
1 long - 1 short repeated	Fire.

## Appendix 7-A (Mandatory)

### Standard Yarding System Whistle Signals

#### Skidder Whistle Signals – Means longer spacing between signals

1 short	Stops moving carriage - stops or goes ahead on slack-puller, as case may be, if carriage is stopped.
2 short	Go ahead on skidding line holding carriage.
1 short - 2 short	Pick up skidding line, easy.
2 short - 1 short	Shake up carriage to clear choker.
2 short - 2 short	Ahead on receding line.
3 short	Ahead on carriage, holding at present level, using interlock.
3 short - 3 short	Ahead easy on skidding line.
2 short - 2 short - 2 short	Slack skyline, cable down.
2 short - 2 short - 2 short - 1 short	Pick up skyline, cable up.
2 short - 2 short - 4 short	Slack receding line.
2 short - 4 short	Slack skidding line.
2 short - 2 short - 1 short	Tighten all lines.
1 short - 4 short	Slack off slack puller.
1 short - 2 short	Pick up slack puller when slack.
2 short - 2 short-plus "X" number of shots	When carriage is in: Number of chokers wanted.
2 short - 2 short - 1 long	Bull choker.
1 short	When carriage is in: Inspect butt rigging.
2 short - 4 short - 1 short	For each addition ten feet of tong line.
1 long - plus "X" number of short	Number of coils of haywire wanted.
5 medium	Tail or second rigger.
5 medium - 4 short	Tail or second rigger and that crew.
2 medium	Skidder head rigger.
3 medium	Hooker.
3 medium - 4 short	Hooker and that crew.
2 long	Ahead on transfer.
2 long - 4 short	Slack transfer.
1 short - 3 short	Ahead on carriage with slack puller line.
1 long	Ahead on haywire.
1 long - 4 short	Slack haywire.
1 long - 3 short	Ahead easy on haywire.
5 long	Climber.
4 long	Foreman.
1 long - 1 short	Start or stop work.
7 long - 2 short	Person injured, call transportation and stretcher.
1 long - 1 short repeated	Fire.

**Stat. Auth.:** ORS 654.025(2) and 656.726(4).

**Stats. Implemented:** ORS 654.001 through 654.295.

**Hist:** OR-OSHA Admin. Order 5-2003, f. 6/02/03, ef. 12/01/03.



## Appendix 7-B

### Double Tree Intermediate Support System

#### RECOMMENDED RIGGING GUIDELINES FOR A DOUBLE TREE INTERMEDIATE SUPPORT SYSTEM

Dragging Load Size (pounds)	Intermed. Support Line Size in Inches (or greater)	Rigging Height in Inches In Tree (diameters at 4.5 ft. above ground)	
		Less than 30 ft.	Between 30 & 40 ft.
0- 5000	7/16	11.0	13.0
5000- 6000	1/2	12.0	14.0
6000- 8000	9/16	12.5	14.5
8000-10000	5/8	13.0	15.0
10000-14000	3/4	14.0	16.0
14000-19000	7/8	14.5	17.0
19000-25000	1	15.5	18.5
25000-32000	1 1/8	16.0	19.5
32000-40000	1 1/4	17.0	20.5
40000-48000	1 3/8	17.5	21.5

**NOTE:** Line sizes are based on IWRC extra-improved plow steel (Cable Logging Systems, p. 25). Smaller rope of equivalent breaking strength is acceptable. Tree diameters are for firmly rooted, sound, straight Douglas Fir trees. Other coniferous trees may be used provided the loads are reduced 25 percent. For example, a 13-inch Western Hemlock support tree rigged at 30 feet can carry a maximum 7500-pound load.

#### RECOMMENDED MINIMUM DIAMETERS FOR WEST COAST DOUGLAS FIR TAIL TREES

(Recommended diameter in inches measured at 4.5 feet)

Skyline Size, Inch	Rigging Height, Feet					
	30	40	50	60	70	80
5/8	13.5	16.0	18.5	20.5	22.5	24.5
3/4	14.5	17.0	19.5	22.0	24.5	26.5
7/8	15.0	18.0	20.5	23.0	25.5	28.0
1	16.0	19.0	21.5	24.5	27.0	29.0
1 1/8	16.5	20.0	22.5	25.5	28.0	30.5
1 1/4	17.5	21.0	23.5	26.5	29.0	31.5
1 3/8	18.0	21.5	24.5	27.5	30.0	32.5
1 1/2	18.5	22.5	25.0	28.5	31.0	33.5
1 5/8	19.5	23.0	26.0	29.0	31.5	34.5
1 3/4	20.0	23.5	26.5	30.0	32.5	35.5
1 7/8	20.5	24.5	27.5	30.5	33.5	36.5
2	21.0	25.0	28.5	31.5	34.5	37.5

**NOTE:** Table is for sound, straight Douglas Fir. Add 2 inches to above diameters when using other coniferous species.

**Stat. Auth.:** ORS 654.025(2) and 656.726(4).

**Stats. Implemented:** ORS 654.001 through 654.295.

**Hist:** OR-OSHA Admin. Order 5-2003, f. 6/02/03, ef. 12/01/03.



**OAR 437 Division 7, Forest Activities  
Appendix 7-C (Mandatory Curriculum)**

**BASIC WILDLAND FIRE SAFETY TRAINING**

---

**BLOCK 1: FIRE PROTECTION STATUTES AND RULES**

1. Fire Protection System in Oregon
2. Need for This Training Course
3. Summary

**BLOCK 2: BASIC FIRE BEHAVIOR**

1. How a Fire Burns
2. How a Fire Spreads
3. The Fire Environment
4. Summary

**BLOCK 3: BASIC FIRE CONTROL**

1. Pre-planning for an Operation Fire
2. Size-up
3. Initial Attack
4. Control
5. Mop-up

**BLOCK 4: BASIC FIRELINE SAFETY**

1. The 18 Watch Out Situations
2. The Ten Standard Fire Fighting Orders
3. LCES – A System for Operational Safety
4. Lessons learned from prior experiences
5. Hazards associated with aerial retardant drops

**Stat. Auth.:** ORS 654.025(2) and 656.726(4).

**Stats. Implemented:** ORS 654.001 through 654.295.

**Hist:** OR-OSHA Admin. Order 5-2003, f. 6/02/03, ef. 12/01/03.  
OR-OSHA Admin. Order 2-2005, f. 5/27/05, ef. 6/1/05.



## Appendix 7-D (Mandatory)

### Hoisting Personnel Up Metal Spars

**(1)** When it is necessary to hoist personnel up a raised metal spar:

**(a)** A meeting attended by the qualified machine operator, signal person, person to be hoisted, and the person responsible for the task to be performed must be held to review the requirements of this section and the procedures to be followed.

**(b)** The machine operator must determine that all systems, controls and safety devices are activated and functioning properly before hoisting personnel.

**(c)** The machine operator must remain at the controls at all times when hoisting personnel.

**(d)** The hoisting drum must have a system or device on the power train, other than the brake, which regulates the lowering rate of speed (controlled load lowering). Free falling is prohibited.

**(e)** Drums used for hoisting personnel must have sufficient flange depth to prevent the hoisting line from running off the drum.

**(f)** A person must attend the drum used for hoisting personnel to make certain the hoisting line spools evenly.

**(g)** When used, hoisting line fair-leads must be kept in alignment and free from fouling at all times.

**(h)** When personnel are hoisted in a pass chain, work seat, or other device, they must wear a full body harness that is attached to the hoisting line with a lanyard no longer than 6 feet in length.

**(i)** All rigging used for hoisting personnel must be inspected by a competent person before use. Any defect found must be corrected before hoisting personnel.

**(j)** Hoisting of personnel must be performed in a slow, controlled, cautious manner with no sudden movements.

**(k)** The movement of a vehicle, machine, or equipment must not be used to raise or lower the person being hoisted.

**(l)** The person being hoisted must be in continuous sight of, and in direct communication with, the operator or signal person.

**(m)** Machines, equipment, or tools, such as power saws, loaders, etc., must not be operated if the noise could interfere with the communication between the person being hoisted and the signal person or operator.

**(n)** The hoisting drum brakes and locking devices must be engaged when the person being hoisted is in a stationary working position.

## Appendix 7-D (Mandatory)

### Hoisting Personnel Up Metal Spars

(o) Hoisting of personnel must be promptly discontinued upon indication of any dangerous weather conditions or other impending danger.

(p) Personnel must not be allowed to stand or work below the person being hoisted, or in any area where they could be struck by falling objects.

(2) When a passline is used while hoisting personnel, it must:

(a) Not be less than 5/16-inch nor larger than 1/2-inch diameter.

(b) Not be subjected to sawing on other lines or rigging and kept clear of moving lines and rigging.

(c) Be of one continuous length and in good condition with no splices, knots, mollies or eye-to-eye splices between the ends.

(d) Be long enough to provide three wraps on the drum before the climber leaves the ground.

(e) Have three tuck eyes only.

(f) Be attach to a powered drum with shackles or equivalent means.

(g) Be fitted with links or rings to prevent employees from being pulled into the passline block or hoisting line sheave.

(3) When a line other than a passline is used while hoisting personnel, it must:

(a) Not be less than 5/16-inch in diameter.

(b) Meet the requirements of (2)(b) through (g).

(4) When the hoisting line is larger than 1/2-inch diameter, precautions must be taken to ensure that the weight of line from the drum to the hoisting sheave will never be greater than the weight on the other side of the hoisting sheave, excluding personnel or materials being hoisted.

(5) When a passline chain is used while hoisting personnel, it must:

(a) Not be less than 5/16-inch alloy or 3/8-inch high test chain and must not contain cold shuts or wire strands.

(b) Be attached to the end of the passline with a screw-pin shackle, a slip-pin shackle with a nut and molly, or a ring large enough to prevent going through the pass block.

## Appendix 7-D (Mandatory)

### Hoisting Personnel Up Metal Spars

**(6)** When a pass block is used while hoisting personnel, it must:

- (a)** Be inspected before placing in each spar and the necessary replacement or repairs made before they are hung.
- (b)** Have bearings that are kept well lubricated.
- (c)** Not be used for heavier strains or lines than those for which it is constructed.
- (d)** Be fitted with line guards and used in a manner that prevents fouling.
- (e)** Have the shells bolted under the sheaves.
- (f)** Have the bearing pin securely locked and nuts keyed or be a type of block that positively secures the nut and pin.
- (g)** Be equipped with a sheave not less than 6 inches in diameter.

**Stat. Auth.:** ORS 654.025(2) and 656.726(4).

**Stats. Implemented:** ORS 654.001 through 654.295.

**Hist:** OR-OSHA Admin. Order 5-2003, f. 6/02/03, ef. 12/01/03.



## Appendix 7-E (Mandatory)

### Rigging Wooden Spar Trees

- (1)** Spar trees must be:
  - (a)** Examined carefully for defects before being selected.
  - (b)** Sound, straight, green wood.
  - (c)** Of sufficient diameter to withstand the strains to be imposed.
- (2)** Trees having defects that impair their strength must not be used for spar trees.
- (3)** Douglas fir or spruce must be used as spar trees when they are available.
- (4)** If species other than douglas fir or spruce must be used as a spar tree, additional guylines, tree plates or other precautions must be taken to ensure that the tree will withstand the strains to be imposed.
- (5)** Raised trees must be identified and marked as such.
- (6)** Wood spar lead blocks used for yarding, swinging, loading and unloading must:
  - (a)** Be of the type and construction designed for this purpose;
  - (b)** Be bolted with not less than two bolts through the shells below the sheaves in a manner that will retain the sheave and line in case of bearing pin failure (this does not apply to haulback lead blocks); and
  - (c)** Have a sheave diameter of not less than 20 times the diameter of the mainline.
- (7)** Blocks used to lead lines directly to yarding, loading or unloading machines other than passline or strawline blocks must be hung:
  - (a)** In both eyes or "D"s of the straps (threaded straps are prohibited); or
  - (b)** With a choker(s) that has the ferrule seated in the socket of the bell or hook in a manner that will prevent the ferrule from coming unbuttoned.
- (8)** Wood spar haulback and mainline loading blocks must be hung as close as possible to support guylines.
- (9)** All wood head spar trees must be equipped with passlines, chains and blocks as required by Appendix 7-D.

**Appendix 7-E (Mandatory)**  
**Rigging Wooden Spar Trees**

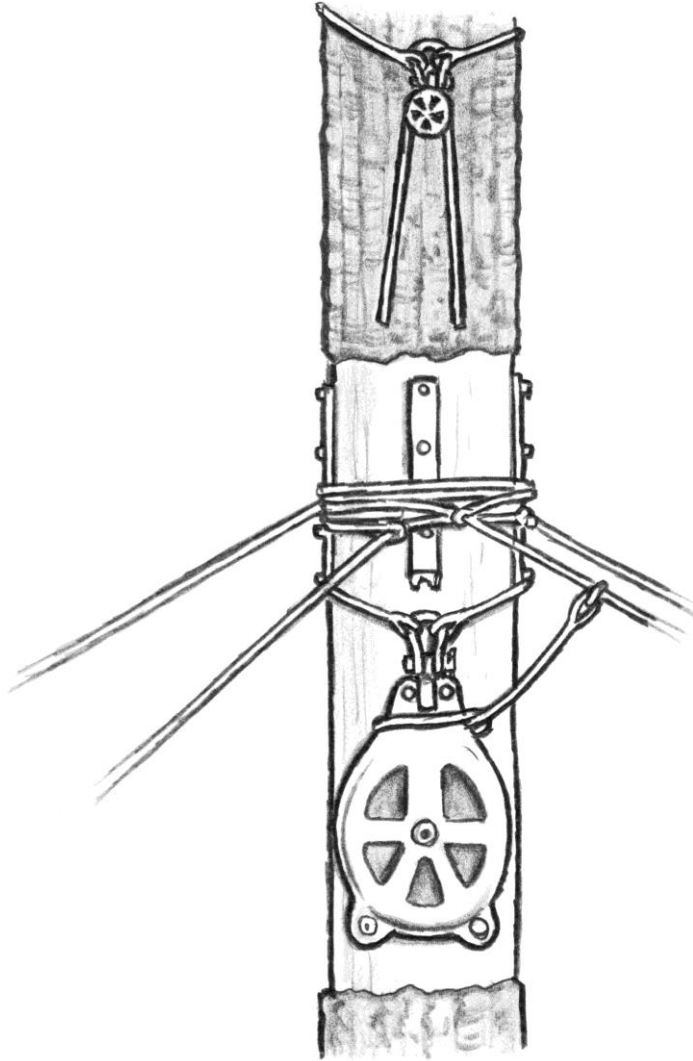

**Figure 7-38 – Rigging – Wood Spar**

**Stat. Auth.:** ORS 654.025(2) and 656.726(4).  
**Stats. Implemented:** ORS 654.001 through 654.295.  
**Hist:** OR-OSHA Admin. Order 5-2003, f. 6/02/03, ef. 12/01/03.

## Appendix 7-F (Mandatory)

### Radio Permits and Radio Signal Permit Area Map

#### RADIO PERMITS

Permits for either radio-activated signaling or machine functions in cable logging operations will be issued by the Department of Consumer and Business Services, Oregon Occupational Safety and Health Division (Oregon OSHA), on the following basis:

**(1)** Radio equipment, in use at cable logging sites, which is primarily used for voice communication must be on a separate assigned frequency from radio equipment primarily used to initiate whistles or other audible signaling devices or to control any machine, material handling device, or other equipment hazardous to employees.

**(2)** Any radio frequency, governed by the Federal Communications Commission, for tone coded control of audible signal or machine functions will be issued permits contingent on compatibility with other systems in use and based on OAR 437-007-1405.

**(3)** 154.57, 154.60, 75.48 and 75.56 MHz channels are to be used as two tone sequential coded channels for activation of the audible signaling devices and machine functions in cable logging with a maximum 1/2 watt output measured at the antenna terminals. 75.56 MHz is to be used for machine functions only.

**(4)** All radio devices, tone coded for either signal or machine functions, associated with logging except those used for voice communications, must meet or exceed the following requirements, specifications, tolerances and tests:

**(a)** Transmitters used for voice transmission will comply with Federal Communications Commission requirements.

**(b)** Tone-coded radio systems which activate audible signals or machine functions must transmit and decode only by the use of multi-tone frequencies assigned by the Department of Consumer and Business Services, Oregon-OSHA.

**(c)** The receiver sensitivity must be capable of attaining .6 microvolt, or greater, for 12 db SINAD ratio for VHF frequencies and .7 microvolt, or greater for UHF frequencies. Effective January 1, 1984, all radio systems receiver sensitivity must be capable of attaining .4 microvolt, or greater, for 12 db SINAD ratio for VHF frequencies and .5 microvolt, or greater, for UHF frequencies. When interference is a factor, the receiver may be desensitized for the promotion of safety by a person qualified in accordance with OAR 437-007-1405.

**(d)** The receiver spurious response attenuation shall be at least 40 db on present systems. On all new radio systems put into service after January 1, 1992, the receiver spurious response attenuation must be at least 60 db. These measurements shall be made as specified by the Electronics Industries Association (EIA).

## Appendix 7-F (Mandatory)

### Radio Permits and Radio Signal Permit Area Map

**(e)** The receiver selectivity must be more than 40 db at  $\pm 30$  KHz. On all new radio signal systems put into service after January 1, 1992, the receiver selectivity must be at least 60 db at  $\pm 30$  KHz. This measurement shall be made by EIA standards.

**(f)** The receiver decoder tone frequency must not exceed 6 Hertz above or below the assigned tone frequency.

**(g)** The drift of the transmitter encoder must not exceed 6 Hertz above or below the assigned tone frequency.

**(h)** Radio systems must operate within the specified tolerances at any temperature within the range of -30 degrees C to +60 degrees C.

**(i)** Radio-signaling systems which may be subjected to the entrance of moisture during use, must be tested within 15 minutes after being subjected to the following conditions and must continue to function properly. The transmitter and receiver must be placed in a humidity chamber for eight hours where the humidity has been maintained at not less than 90 percent and where a 40 degrees C temperature has been maintained.

**(j)** Switches of transmitters used to send whistle signals or activate equipment associated with cable systems of logging must be designed in such a manner whereby two buttons, motions or a combination of these must be required simultaneously to cause activation of the system. Arrangement of the activating switches must be such that the operator can transmit signals easily by the use of either hand but cannot easily activate the transmitter accidentally.

**(k)** All receivers intended to be mounted on or in the yarder or similar equipment and all portable transmitters shall continue to maintain specified mechanical and electrical performance during and after being subjected to vibration of the magnitude and amplitude as follows:

**(A)** The equipment must meet all electrical requirements after being vibrated with simple harmonic motion having an amplitude of 0.015" (total excursion of 0.030") with the frequency varied uniformly between 10 and 30 cycles per second, and an amplitude of 0.0075" (total excursion of 0.015") with the frequency varied uniformly from 30 to 60 cycles per second.

**(B)** The entire cycle of frequencies for each group, i.e., 10 to 30 cps and 30 to 60 cps, shall be accomplished in five minutes and repeated three times. The above motion must be applied for a total period of 30 minutes in each of three directions, namely, the directions parallel to both axes of the base, and perpendicular to the plane of base.

## Appendix 7-F (Mandatory)

### Radio Permits and Radio Signal Permit Area Map

(I) All portable transmitters must continue to maintain specified mechanical and electrical performance after being subjected to the following shock test. The equipment must be dropped once on each of five surfaces from a height of 4 feet onto a smooth concrete floor.

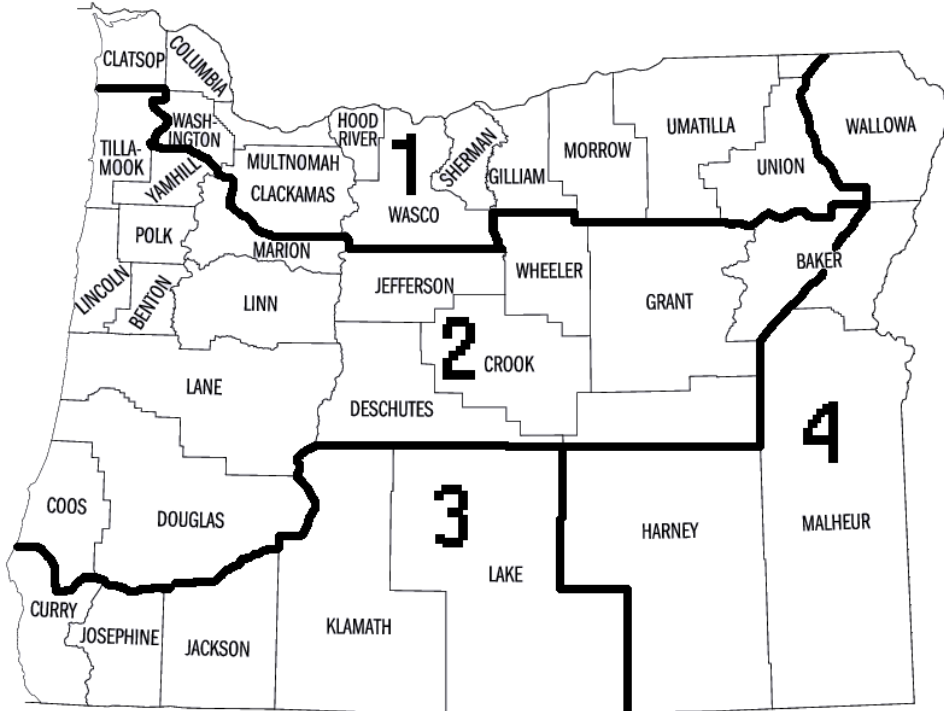

**Stat. Auth.:** ORS 654.025(2) and 656.726(4).  
**Stats. Implemented:** ORS 654.001 through 654.295.  
**Hist:** OR-OSHA Admin. Order 5-2003, f. 6/02/03, ef. 12/01/03.



## Appendix 7-G (Mandatory)

### Respirator Medical Evaluation Questionnaire

#### To the employer:

Answers to questions in Section 1, and to question 9 in Section 2 of Part A, do not require a medical examination.

#### To the employee:

Can you read (circle one): Yes / No

Your employer must allow you to answer this questionnaire during normal working hours, or at a time and place that is convenient to you. To maintain your confidentiality, your employer or supervisor must not look at or review your answers, and your employer must tell you how to deliver or send this questionnaire to the health care professional who will review it.

**Part A. Section 1. (Mandatory)** The following information must be provided by every employee who has been selected to use any type of respirator (please print).

1. Today's date: \_\_\_\_\_
2. Your name: \_\_\_\_\_
3. Your age (to nearest year): \_\_\_\_\_
4. Sex (circle one): Male / Female
5. Your height: \_\_\_\_\_ ft. \_\_\_\_\_ in.
6. Your weight: \_\_\_\_\_ lbs.
7. Your job title: \_\_\_\_\_
8. A phone number where you can be reached by the health care professional who reviews this questionnaire (include the Area Code): (\_\_\_\_\_) \_\_\_\_\_
9. The best time to phone you at this number: \_\_\_\_\_
10. Has your employer told you how to contact the health care professional who will review this questionnaire (circle one): Yes / No
11. Check the type of respirator you will use (you can check more than one category):  
\_\_\_\_\_ N, R, or P disposable respirator (filter-mask, non-cartridge type only).  
\_\_\_\_\_ Other type (for example, half- or full-facepiece type, powered-air purifying, supplied-air, self-contained breathing apparatus).

## Appendix 7-G (Mandatory)

### Respirator Medical Evaluation Questionnaire

12. Have you worn a respirator (circle one): Yes / No

If "yes," what type(s): \_\_\_\_\_

**Part A. Section 2. (Mandatory)** Questions 1 through 9 below must be answered by every employee who has been selected to use any type of respirator (please circle "yes" or "no").

1. Do you currently smoke tobacco, or have you smoked tobacco in the last month:  
Yes / No

2. Have you ever had any of the following conditions?

a. Seizures (fits): Yes / No

b. Diabetes (sugar disease): Yes / No

c. Allergic reactions that interfere with your breathing: Yes / No

d. Claustrophobia (fear of closed-in places): Yes / No

e. Trouble smelling odors: Yes / No

3. Have you ever had any of the following pulmonary or lung problems?

a. Asbestosis: Yes / No

b. Asthma: Yes / No

c. Chronic bronchitis: Yes / No

d. Emphysema: Yes / No

e. Pneumonia: Yes / No

f. Tuberculosis: Yes / No

g. Silicosis: Yes / No

h. Pneumothorax (collapsed lung): Yes / No

i. Lung cancer: Yes / No

j. Broken ribs: Yes / No

k. Any chest injuries or surgeries: Yes / No

l. Any other lung problem that you've been told about: Yes / No

## Appendix 7-G (Mandatory)

### Respirator Medical Evaluation Questionnaire

4. Do you currently have any of the following symptoms of pulmonary or lung illness?
- a. Shortness of breath: Yes / No
  - b. Shortness of breath when walking fast on level ground or walking up a slight hill or incline: Yes / No
  - c. Shortness of breath when walking with other people at an ordinary pace on level ground: Yes / No
  - d. Have to stop for breath when walking at your own pace on level ground: Yes / No
  - e. Shortness of breath when washing or dressing yourself: Yes / No
  - f. Shortness of breath that interferes with your job: Yes / No
  - g. Coughing that produces phlegm (thick sputum): Yes / No
  - h. Coughing that wakes you early in the morning: Yes / No
  - i. Coughing that occurs mostly when you are lying down: Yes / No
  - j. Coughing up blood in the last month: Yes / No
  - k. Wheezing: Yes / No
  - l. Wheezing that interferes with your job: Yes / No
  - m. Chest pain when you breathe deeply: Yes / No
  - n. Any other symptoms that you think may be related to lung problems: Yes / No
5. Have you ever had any of the following cardiovascular or heart problems?
- a. Heart attack: Yes / No
  - b. Stroke: Yes / No
  - c. Angina: Yes / No
  - d. Heart failure: Yes / No
  - e. Swelling in your legs or feet (not caused by walking): Yes / No
  - f. Heart arrhythmia (heart beating irregularly): Yes / No
  - g. High blood pressure: Yes / No
  - h. Any other heart problem that you've been told about: Yes / No

## Appendix 7-G (Mandatory)

### Respirator Medical Evaluation Questionnaire

6. Have you ever had any of the following cardiovascular or heart symptoms?
- a. Frequent pain or tightness in your chest: Yes / No
  - b. Pain or tightness in your chest during physical activity: Yes / No
  - c. Pain or tightness in your chest that interferes with your job: Yes / No
  - d. In the past two years, have you noticed your heart skipping or missing a beat:  
Yes / No
  - e. Heartburn or indigestion that is not related to eating: Yes / No
  - f. Any other symptoms that you think may be related to heart or circulation problems:  
Yes / No
7. Do you currently take medication for any of the following problems?
- a. Breathing or lung problems: Yes / No
  - b. Heart trouble: Yes / No
  - c. Blood pressure: Yes / No
  - d. Seizures (fits): Yes / No
8. If you've used a respirator, have you ever had any of the following problems? (If you've never used a respirator, check the following space and go to question 9 \_\_\_\_.)
- a. Eye irritation: Yes / No
  - b. Skin allergies or rashes: Yes / No
  - c. Anxiety: Yes / No
  - d. General weakness or fatigue: Yes / No
  - e. Any other problem that interferes with your use of a respirator: Yes / No
9. Would you like to talk to the health care professional who will review this questionnaire about your answers to this questionnaire: Yes / No

## Appendix 7-G (Mandatory)

### Respirator Medical Evaluation Questionnaire

Questions 10 through 15 below must be answered by every employee who has been selected to use either a full-facepiece respirator or a self-contained breathing apparatus (SCBA). For employees who have been selected to use other types of respirators, answering these questions is voluntary.

10. Have you ever lost vision in either eye (temporarily or permanently): Yes / No
11. Do you currently have any of the following vision problems?
- a. Wear contact lenses: Yes / No
  - b. Wear glasses: Yes / No
  - c. Color blind: Yes / No
  - d. Any other eye or vision problem: Yes / No
12. Have you ever had an injury to your ears, including a broken ear drum: Yes / No
13. Do you currently have any of the following hearing problems?
- a. Difficulty hearing: Yes / No
  - b. Wear a hearing aid: Yes / No
  - c. Any other hearing or ear problem: Yes / No
14. Have you ever had a back injury: Yes / No
15. Do you currently have any of the following musculoskeletal problems?
- a. Weakness in any of your arms, hands, legs, or feet: Yes / No
  - b. Back pain: Yes / No
  - c. Difficulty fully moving your arms and legs: Yes / No
  - d. Pain or stiffness when you lean forward or backward at the waist: Yes / No
  - e. Difficulty fully moving your head up or down: Yes / No
  - f. Difficulty fully moving your head side-to-side: Yes / No
  - g. Difficulty bending at your knees: Yes / No
  - h. Difficulty squatting to the ground: Yes / No

## Appendix 7-G (Mandatory)

### Respirator Medical Evaluation Questionnaire

- i. Climbing a flight of stairs or a ladder carrying more than 25 lbs: Yes / No
- j. Any other muscle or skeletal problem that interferes with using a respirator: Yes / No

**Part B.** Any of the following questions, and other questions not listed, may be added to the questionnaire at the discretion of the health care professional who will review the questionnaire.

1. In your present job, are you working at high altitudes (over 5,000 feet) or in a place that has lower than normal amounts of oxygen: Yes / No

If "yes," do you have feelings of dizziness, shortness of breath, pounding in your chest, or other symptoms when you're working under these conditions: Yes / No

2. At work or at home, have you ever been exposed to hazardous solvents, hazardous airborne chemicals (e.g., gases, fumes, or dust), or have you come into skin contact with hazardous chemicals: Yes / No

If "yes," name the chemicals if you know them: \_\_\_\_\_

---

3. Have you ever worked with any of these materials, or under any of the conditions, listed below:

- a. Asbestos: Yes / No
- b. Silica (e.g., in sandblasting): Yes / No
- c. Tungsten/cobalt (e.g., grinding or welding this material): Yes / No
- d. Beryllium: Yes / No
- e. Aluminum: Yes / No
- f. Coal (for example, mining): Yes / No
- g. Iron: Yes / No
- h. Tin: Yes / No
- i. Dusty environments: Yes / No
- j. Any other hazardous exposures: Yes / No

## Appendix 7-G (Mandatory)

### Respirator Medical Evaluation Questionnaire

If "yes," describe these exposures: \_\_\_\_\_

---

4. List any second jobs or side businesses you have:

5. List your previous occupations:

6. List your current and previous hobbies:

7. Have you been in the military services? Yes / No

If "yes," were you exposed to biological or chemical agents (either in training or combat) Yes / No

8. Have you ever worked on a HAZMAT team? Yes / No

9. Other than medications for breathing and lung problems, heart trouble, blood pressure, and seizures mentioned earlier in this questionnaire, are you taking any other medications for any reason (including over-the-counter medications): Yes / No

If "yes," name the medications if you know them: \_\_\_\_\_

---

10. Will you be using any of the following items with your respirator(s)?

a. HEPA Filters: Yes / No

b. Canisters (for example, gas masks): Yes / No

c. Cartridges: Yes / No

11. How often are you expected to use the respirator(s) (circle "yes" or "no" for all answers that apply to you)?:

a. Escape only (no rescue): Yes / No

b. Emergency rescue only: Yes / No

c. Less than 5 hours per week: Yes / No

d. Less than 2 hours per day: Yes / No

**Appendix 7-G (Mandatory)**

**Respirator Medical Evaluation Questionnaire**

2 to 4 hours per day: Yes / No

Over 4 hours per day: Yes / No

12. During the period you are using the respirator(s), is your work effort:

a. Light (less than 200 kcal per hour): Yes / No

If "yes," how long does this period last during the average shift: \_\_\_\_\_ hrs. \_\_\_\_\_ mins.

Examples of a light work effort are sitting while writing, typing, drafting, or performing light assembly work; or standing while operating a drill press (1-3 lbs.) or controlling machines.

b. Moderate (200 to 350 kcal per hour): Yes / No

If "yes," how long does this period last during the average shift: \_\_\_\_\_ hrs. \_\_\_\_\_ mins.

Examples of moderate work effort are sitting while nailing or filing; driving a truck or bus in urban traffic; standing while drilling, nailing, performing assembly work, or transferring a moderate load (about 35 lbs.) at trunk level; walking on a level surface about 2 mph or down a 5-degree grade about 3 mph; or pushing a wheelbarrow with a heavy load (about 100 lbs.) on a level surface.

c. Heavy (above 350 kcal per hour): Yes / No

If "yes," how long does this period last during the average shift: \_\_\_\_\_ hrs. \_\_\_\_\_ mins.

Examples of heavy work are lifting a heavy load (about 50 lbs.) from the floor to your waist or shoulder; working on a loading dock; shoveling; standing while bricklaying or chipping castings; walking up an 8-degree grade about 2 mph; climbing stairs with a heavy load (about 50 lbs.).

13. Will you be wearing protective clothing and/or equipment (other than the respirator) when you're using your respirator: Yes / No

If "yes," describe this protective clothing and/or equipment: \_\_\_\_\_

14. Will you be working under hot conditions (temperature exceeding 77 degrees F):  
Yes / No

15. Will you be working under humid conditions: Yes / No

16. Describe the work you'll be doing while you're using your respirator(s):

---

---

## Appendix 7-G (Mandatory)

### Respirator Medical Evaluation Questionnaire

17. Describe any special or hazardous conditions you might encounter when you're using your respirator(s) (for example, confined spaces, life-threatening gases):

---

18. Provide the following information, if you know it, for each toxic substance that you'll be exposed to when you're using your respirator(s):

Name of the first toxic substance: \_\_\_\_\_  
Estimated maximum exposure level per shift: \_\_\_\_\_  
Duration of exposure per shift: \_\_\_\_\_  
Name of the second toxic substance: \_\_\_\_\_  
Estimated maximum exposure level per shift: \_\_\_\_\_  
Duration of exposure per shift: \_\_\_\_\_  
Name of the third toxic substance: \_\_\_\_\_  
Estimated maximum exposure level per shift: \_\_\_\_\_  
Duration of exposure per shift: \_\_\_\_\_  
The name of any other toxic substances that you'll be exposed to while using your respirator: \_\_\_\_\_

19. Describe any special responsibilities you'll have while using your respirator(s) that may affect the safety and well-being of others (for example, rescue, security): \_\_\_\_\_

---

**Stat. Auth.:** ORS 654.025(2) and 656.726(4).

**Stats. Implemented:** ORS 654.001 through 654.295.

**Hist:** OR-OSHA Admin. Order 5-2003, f. 6/02/03, ef. 12/01/03.



## Apéndice 7-G (Obligatorio)

### CUESTIONARIO DE EVALUACION MEDICA RESPIRATORIA

Este es un apéndice que no es obligatorio añadir al OAR 437-004-1040, Respiradores.

**COMPAÑÍA Y/O PATRON:** Tienen que proveer la información en parte B de este documento.

**A. TRABAJADOR:** Su compañía o patrón debe dejarlo responder estas preguntas durante horas normales de trabajo o durante una hora y lugar que sea conveniente para usted.

**(Obligatorio)** La siguiente información tiene que ser provisto por cada empleado que es designado a usar cualquier tipo de respirador (escribe claro por favor).

Fecha de Hoy: \_\_\_\_\_ Su nombre: \_\_\_\_\_ Edad: \_\_\_\_\_

Género: M / F Estatura: \_\_\_\_\_ Peso: \_\_\_\_\_

Ocupación, título or tipo de trabajo: \_\_\_\_\_

Un número de teléfono donde el profesional de salud quien revisa este cuestionario puede comunicarse con usted (incluya el código de área): \_\_\_\_\_

La mejor hora de comunicarse con usted ha este número de teléfono: AM / PM (Marque uno): \_\_\_\_\_

¿Le explicó su patrón como comunicarse con el profesional de salud revisando este cuestionario? Si / No

Marque el tipo de respirador que usa (puede marcar más de uno):

- a. \_\_\_ N, R, o P respirador desechable (máscara con filtro, sin cartucho)
- b. \_\_\_ Otra clase de respirador (por ejemplo, máscara de media cara, máscara completa, tanque de aire, sistema completo de protección pulmonar).

¿Ha usado usted un respirador? Si / No

Si es afirmativo, ¿Que estilo(s)? \_\_\_\_\_

---

## Apendice 7-G (Obligatorio)

### CUESTIONARIO DE EVALUACION MEDICA RESPIRATORIA

**(Obligatorio)** Preguntas del 1 al 9 tienen que ser contestadas por todo empleado que es designado ha usar cualquier clase de respirador (circule su respuesta).

1. ¿Actualmente, fuma tabaco, o ha fumado tabaco en el último mes? Si / No
  
2. ¿Ha padecido usted de lo siguiente?:
  - Convulsiones Si / No
  - a. Diabetes (azúcar en la sangre) Si / No
  - b. Reacciones alérgicas que interfieren con su respiración Si / No
  - c. Claustrofobia (temor a espacios cerrados) Si / No
  - d. Problemas del olfato Si / No
  
3. ¿Ha padecido usted de los siguientes problemas pulmonares?
  - a. Asbestosis Si / No
  - b. Asma Si / No
  - c. Bronquitis crónica Si / No
  - d. Enfisema Si / No
  - e. Neumonía Si / No
  - f. Tuberculosis Si / No
  - g. Silicosis Si / No
  - h. Neumotorax (desinfe del pulmón) Si / No
  - i. Cáncer del pulmón Si / No
  - j. Fracturas de las costillas Si / No
  - k. Lesiones o cirugía del pecho Si / No
  - l. Otros problemas del pulmón Si / No
  
4. ¿Actualmente tiene Usted alguno de los siguientes síntomas pulmonares o enfermedades del pulmón?:
  - a. Falta de aire Si / No
  - b. Falta de aire cuando camina rápido en superficie plana o cuando el camino es elevado Si / No
  - c. Falta de aire cuando camina con otras personas, normalmente
  - d. en superficie plana Si / No
  - e. El tener que parar para coger aire cuando camina a su ritmo
  - f. en superficie plana Si / No
  - g. Falta de aire cuando usted se lava o se viste Si / No
  - h. Falta de aire lo cual interfiere con su trabajo Si / No
  - i. Tos, la cual produce flema espesa Si / No
  - j. Tos, la cual lo despierta Si / No
  - k. Tos, la cual se manifiesta cuando esta acostado Si / No
  - l. Tos con sangre durante el mes pasado Si / No
  - m. Respiración jadiante Si / No
  - n. Respiración jadiante, la cual interfiere con su trabajo Si / No
  - o. Dolor en el pecho cuando respira profundamente Si / No
  - p. Cualquier otro síntoma o problema el cual usted cree esta relacionado a problemas del pulmón Si / No

## Apéndice 7-G (Obligatorio)

### CUESTIONARIO DE EVALUACION MEDICA RESPIRATORIA

5. ¿Ha padecido usted de los siguientes problemas cardiovasculares o del corazón?:
- a. Ataque al corazón: Si / No
  - b. Derrame cerebral o Embolia: Si / No
  - c. Angina: Si / No
  - d. Problemas del corazón: Si / No
  - e. Hinchazón de las piernas o pies (no causada por el andar): Si / No
  - f. Arritmias del corazón (palpitación irregular): Si / No
  - g. Presión alta de la sangre: Si / No
  - h. Otros problemas del corazón: Si / No
6. ¿Ha padecido Usted de los siguientes síntomas cardiovasculares o del corazón?:
- a. Dolor o presión frecuente del pecho: Si / No
  - b. Dolor o presión del pecho durante actividad física: Si / No
  - c. Dolor o presión del pecho lo cual interfiere con su trabajo: Si / No
  - d. En los últimos dos años ha notado cambios en el ritmo de su corazón: Si / No
  - e. Agrura o indigestión, no ocasionada por la comida: Si / No
  - f. Otros síntomas los cuales usted cree están relacionados a problemas del corazón o circulación: Si / No
7. ¿Actualmente toma usted medicamentos para algunos de los siguientes problemas?:
- a. Problemas de la respiración o de los pulmones: Si / No
  - b. Problemas del corazón: Si / No
  - c. Presión: Si / No
  - d. Convulsiones: Si / No
8. Si Usted ha usado un respirador, ¿ha tenido en alguna ocasión alguno de los siguientes problemas? ( Si usted nunca ha usado un respirador por favor continúe con la pregunta #9).
- a. Irritación de los ojos: Si / No
  - b. Irritación o alergias de la piel: Si / No
  - c. Ansiedad: Si / No
  - d. Agotamiento o debilidad: Si / No
  - e. Algún otro problema que interfiere con el uso del respirador: Si / No
9. Quiere hablar de sus respuestas con el trabajador de salud el cual va a revisar su cuestionario? Si / No

## Apéndice 7-G (Obligatorio)

### CUESTIONARIO DE EVALUACION MEDICA RESPIRATORIA

**(SCBA Máscara completa o aparato completo con aire)** Estas preguntas tienen que ser contestadas obligatoriamente por todo empleado que es designado a usar cualquiera de los siguientes respiradores: máscara completa o aparato completo con aire (SCBA).

1. ¿Ha perdido la vista (temporalmente o permanentemente) en uno o ambos ojos?:  
Si / No
  
2. ¿Actualmente tiene alguno de los siguientes problemas de la vista?:
  - a. Usa lentes de contacto: Si / No
  - b. Usa anteojos: Si / No
  - c. Dificultad en distinguir los colores (acromatopsia): Si / No
  - d. Otros problemas con los ojos o vista?: Si / No
  
3. ¿Ha tenido un trauma en los oídos, incluyendo daño al tímpano?: Si / No
  
4. ¿Actualmente tiene algunos de los siguientes problemas con los oídos?:
  - a. Dificultad al oír: Si / No
  - b. Usa prótesis en el oído: Si / No
  - c. Cualquier otro problema con el sentido de los oídos: Si / No
  
5. ¿Se ha lesionado la espalda?: Si / No
  
6. ¿Actualmente tiene alguno de los siguientes problemas musculoesquelético?:
  - a. Debilidad de los brazos, manos, piernas y pies: Si / No
  - b. Dolor de la espalda: Si / No
  - c. Dificultad al mover los brazos y piernas: Si / No
  - d. Dolor o dificultad al doblar la cintura: Si / No
  - e. Dificultad al mover la cabeza hacia arriba y abajo: Si / No
  - f. Dificultad al mover la cabeza de un lado a otro: Si / No
  - g. Dificultad al doblar las rodillas: Si / No
  - h. Dificultad al ponerse de cuclillas: Si / No
  - i. Subiendo gradas o una escalera cargando más de 25 libras: Si / No
  - j. Cualquier otro problema del esqueleto o de los músculos al cual va interferir con el uso del respirador: Si / No

**Alto:** Conteste las siguientes nueve preguntas si se lo indica el trabajador de salud.

1. ¿En su trabajo presente, trabaja en lugares con medidas bajas de oxígeno?: Si / No  
  
¿Si es afirmativo, tiene mareos, falta de aire, presión en el pecho, u otros síntomas cuando esta trabajando bajo estas condiciones?: Si / No
  
2. ¿En el trabajo o su casa, ha sido usted expuesto a solventes peligrosos, químicas peligrosas transportadas por el aire, (gases, humos, o polvos), o contacto a la piel con químicos peligrosos?: Si / No

## Apendice 7-G (Obligatorio)

### CUESTIONARIO DE EVALUACION MEDICA RESPIRATORIA

Si es afirmativo, nombre del (los) químico(s): \_\_\_\_\_  
\_\_\_\_\_

3. ¿Ha trabajado Usted con los siguientes materiales, o bajo alguna de las siguientes condiciones?:

- |   |         |
|---|---------|
| a. Asbestos   | Si / No |
| b. Sílice   | Si / No |
| c. Cobalto (fibra de metal o material de soldadura) | Si / No |
| d. Berilio  | Si / No |
| e. Aluminio   | Si / No |
| f. Carbón (trabajo en minas)                        | Si / No |
| g. Hierro   | Si / No |
| h. Estaño   | Si / No |
| i. Ambiente polvoroso                               | Si / No |
| j. Otra exposición química                          | Si / No |

Si es afirmativo, describa la(s) exposiciones: \_\_\_\_\_  
\_\_\_\_\_

4. Liste trabajos secundarios u otros trabajos: \_\_\_\_\_  
\_\_\_\_\_

5. Liste sus ocupaciones anteriores: \_\_\_\_\_  
\_\_\_\_\_

6. Liste Pasatiempos presentes y pasados: \_\_\_\_\_  
\_\_\_\_\_

7. ¿Servicio Militar?: Si / No

Si es afirmativo, ¿estuvo expuesto a agentes biológicos o químicos (durante entrenamiento o combate)? Si / No

8. ¿Ha trabajado en un equipo HAZMAT(Grupo de emergencia)? Si / No

9. ¿Fuera de medicinas para la respiración, los pulmones, problemas del corazón, presión, y convulsiones mencionadas anteriormente en este cuestionario, está usted tomando otras medicinas (incluyendo medicinas sin receta médica)? Si / No

Si es afirmativo, nombre las medicinas: \_\_\_\_\_  
\_\_\_\_\_

## Apéndice 7-G (Obligatorio)

### CUESTIONARIO DE EVALUACION MEDICA RESPIRATORIA

#### B. INFORMACION PROPORCIONADA POR LA COMPAÑÍA Y/O PATRON

1. ¿Va el empleado a utilizar alguno de los siguientes artículos con su respirador?
- a. Filtros HEPA Si / No
  - b. Canisters (por ejemplo, máscaras para gas) Si / No
  - c. Cartuchos: Si / No

2. ¿Con que frecuencia usará el empleado el respirador (circule todas las respuestas que sean necesarias)?:

- a. Solamente para escape ( sin rescate) Si / No
- b. Rescate de emergencia Si / No
- c. Menos de 5 horas por semana Si / No
- d. Menos de 2 horas por día Si / No
- e. 2 a 4 horas por día Si / No
- f. Más de 4 horas por día Si / No

3. ¿Durante el periodo que el empleado usa el respirador, el esfuerzo de trabajo es?:

- a. Liviano (menos de 200 Kcal por hora) Si / No

Si es afirmativo, promedio de horas durante turno de trabajo:

horas \_\_\_\_\_ minutos \_\_\_\_\_

*Ejemplos de trabajo liviano son: estar sentado cuando escribe, computación, haciendo planos, o de pie operando maquinaria.*

- b. Moderado (200 a 350 Kcal por hora) Si / No

Si es afirmativo, promedio de horas durante turno de trabajo:

horas \_\_\_\_\_ minutos \_\_\_\_\_

*Ejemplos de trabajo moderado son: estar sentado cuando martilla o archiva, manejar un bus o camión en trafico de la ciudad, perforar, martillar o ensamblar cargas moderadas (35 libras) a nivel de la cintura mientras esta de pie; caminando en superficie plana a 2 mph o hacia abajo, a un nivel de 5 grados a 3 mph; o empujando una carretilla con carga pesada (100 libras) en superficie plana.*

- c. Pesado (más de 350 Kcal por hora): Si / No

Si es afirmativo, promedio de horas durante turno de trabajo:

horas \_\_\_\_\_ minutos \_\_\_\_\_

*Ejemplos de trabajo pesado son levantar cercas de 50 libras del suelo a la cintura o hombros, remover material con una pala, empacar heno, caminar hacia arriba a 8 grados a 2 mph, subiendo gradas cargando carga pesada (50 libras).*

**Apendice 7-G (Obligatorio)**

**CUESTIONARIO DE EVALUACION MEDICA RESPIRATORIA**

4. ¿Va el empleado a utilizar ropa o equipo protector además del respirador? Si / No

Si es afirmativo describa el equipo que va a usar: \_\_\_\_\_  
\_\_\_\_\_

5. ¿Va el empleado a trabajar en temperaturas altas (temperaturas mas de 77 F)?  
Si / No

6. ¿Va el empleado a trabajar en condiciones húmedas? Si / No

7. Describa el trabajo que el empleado hará cuando usa el respirador: \_\_\_\_\_  
\_\_\_\_\_

8. Describa condiciones especiales o condiciones peligrosas las cuales el empleado puede enfrentar cuando usa el respirador (por ejemplo, espacios confinados, gases fulminantes):  
\_\_\_\_\_  
\_\_\_\_\_

9. Provea la siguiente información por cada sustancia tóxica a que el empleado puede estar expuesto cuando use el (los) respiradores):

Primera sustancia tóxica: \_\_\_\_\_  
\_\_\_\_\_

Nivel máximo de exposición por turno de trabajo: \_\_\_\_\_  
\_\_\_\_\_

Tiempo de exposición por turno de trabajo: \_\_\_\_\_  
\_\_\_\_\_

Segunda sustancia tóxica: \_\_\_\_\_  
\_\_\_\_\_

Nivel máximo de exposición por turno de trabajo: \_\_\_\_\_  
\_\_\_\_\_

Tiempo de exposición por turno de trabajo: \_\_\_\_\_  
\_\_\_\_\_

Tercera sustancia tóxica: \_\_\_\_\_  
\_\_\_\_\_

Nivel máximo de exposición por turno de trabajo: \_\_\_\_\_  
\_\_\_\_\_

Tiempo de exposición por turno de trabajo: \_\_\_\_\_  
\_\_\_\_\_

## Apendice 7-G (Obligatorio)

### CUESTIONARIO DE EVALUACION MEDICA RESPIRATORIA

El nombre de cualquier otra sustancia tóxica(s) al cual ellos puedan estar expuestos mientras usan el respirador: \_\_\_\_\_

10. Describa otras responsabilidades especiales que los empleados tendrán que usar durante el tiempo que estarán usando respiradores que pueden afectar la seguridad de otras personas ( por ejemplo, rescate, seguridad): \_\_\_\_\_

\_\_\_\_\_  
\_\_\_\_\_

**Stat. Auth.:** ORS 654.025(2) and 656.726(4).

**Stats. Implemented:** ORS 654.001 through 654.295.

**Hist:** OR-OSHA Admin. Order 5-2003, f. 6/02/03, ef. 12/01/03.

## Appendix 7-H (Mandatory)

### A-Frames and V-Leads

#### A-Frames

- (1) A-frames must be guyed or braced to provide stability and prevent tipping.
- (2) A-frame bases must be secured against displacement and the tops must be securely bolted or lashed to prevent displacement.
- (3) Where guylines are used, A-frames must be provided with not less than one snap guy and two guylines securely attached, anchored and spread to form an angle 70 degrees to 90 degrees opposite the direction of stress or strain.

#### V-Leads

- (1) Swinging or yarding with a V-lead is prohibited, except under the following conditions:
  - (a) No additional hazards to the logging machine operator or to other employees in the area will be created because of this operating procedure.
  - (b) The spar must be equipped with fairleads for both main and haulback lines.
  - (c) The mainline and haulback drums must be located not more than 25 feet from the base of the spar.
  - (d) Not less than six guylines must be used.
  - (e) Each guyline on the side opposite the direction of stresses imposed by yarding or swinging must have a breaking strength at least 20 percent greater than that of the mainline used, or one extra guyline at least equal in strength to the mainline used must be placed to oppose the stresses imposed by yarding or swinging in a V-lead, and when the lead is changed, the required extra guyline must be repositioned to oppose the stresses due to this changed direction of pull.
  - (f) No yarding or swinging in a V-lead is performed at less than an angle of 67.5 degrees formed between the logging machine, fairlead and the yarding or swing road on either side of the spar, unless the machine controls and operator are located in a safe position beyond possible contact by chokers, lines, rigging, or logs.

**Stat. Auth.:** ORS 654.025(2) and 656.726(4).

**Stats. Implemented:** ORS 654.001 through 654.295.

**Hist:** OR-OSHA Admin. Order 5-2003, f. 6/02/03, ef. 12/01/03.



Appendix 7-I (Mandatory)

Guyline Positioning

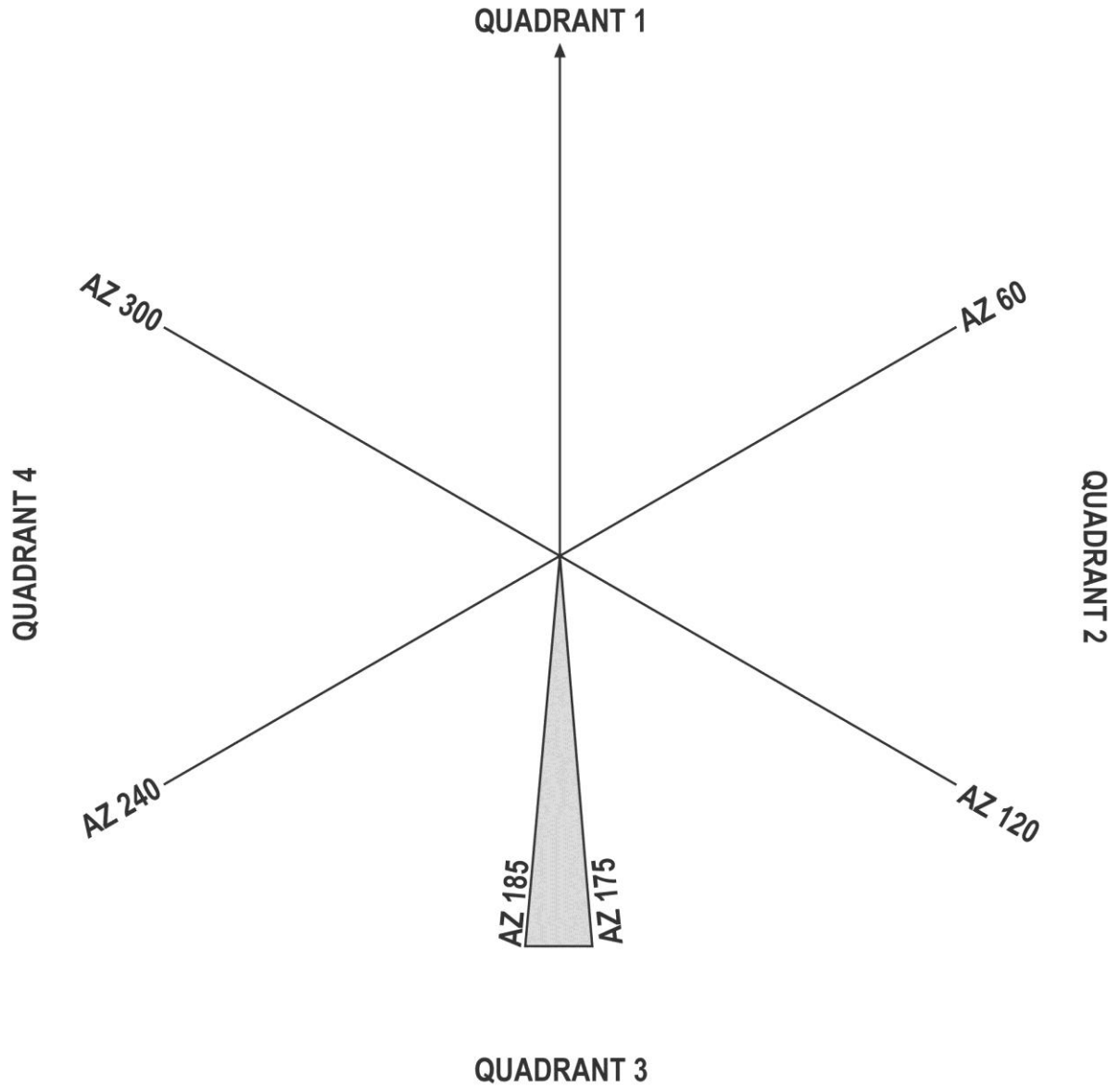
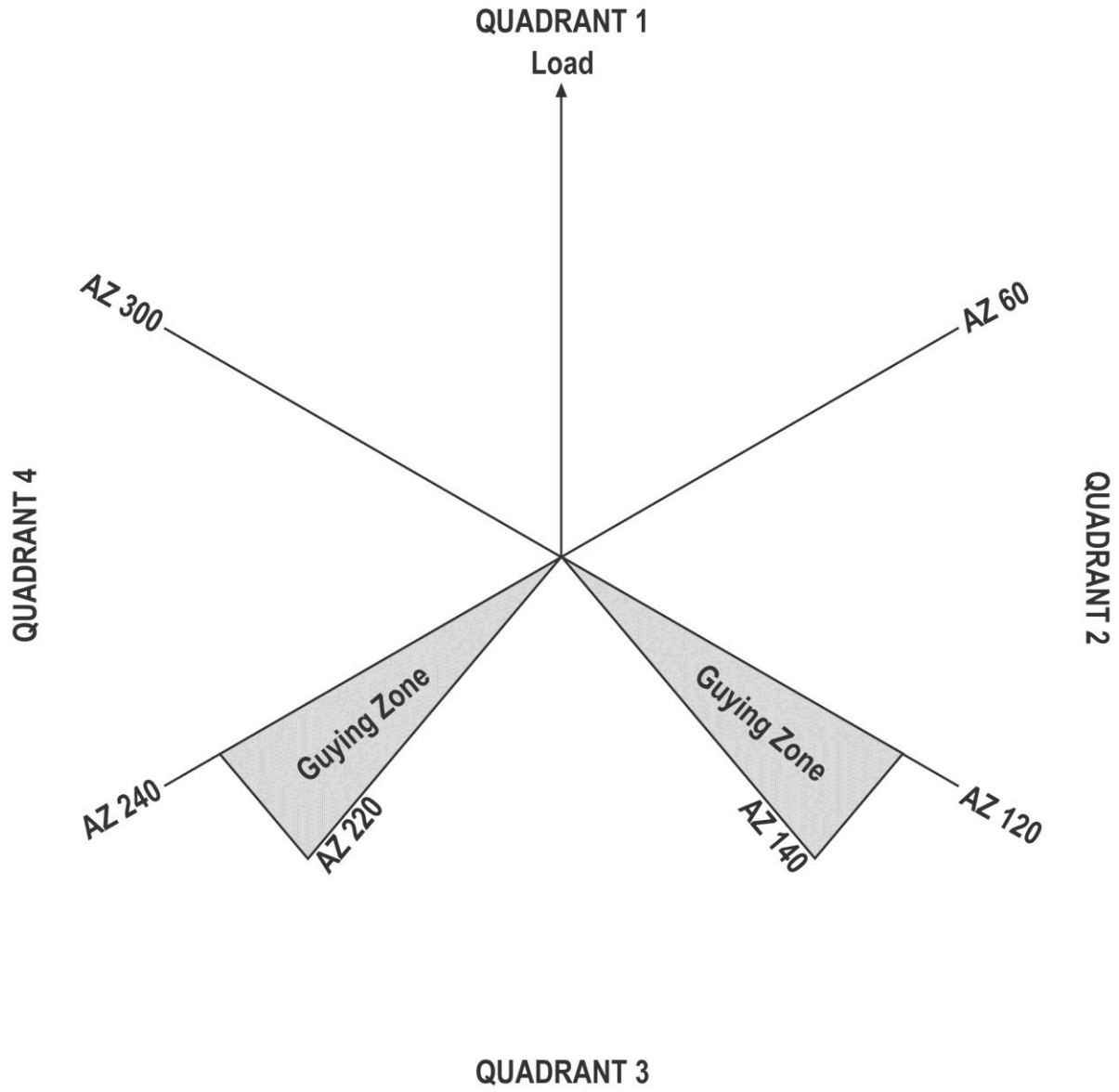

Figure 7-39 – 1 Guyline Case

**Appendix 7-I (Mandatory)**

**Guyline Positioning**



**Figure 7-40 – 2 Guyline Case**

Appendix 7-I (Mandatory)

Guyline Positioning

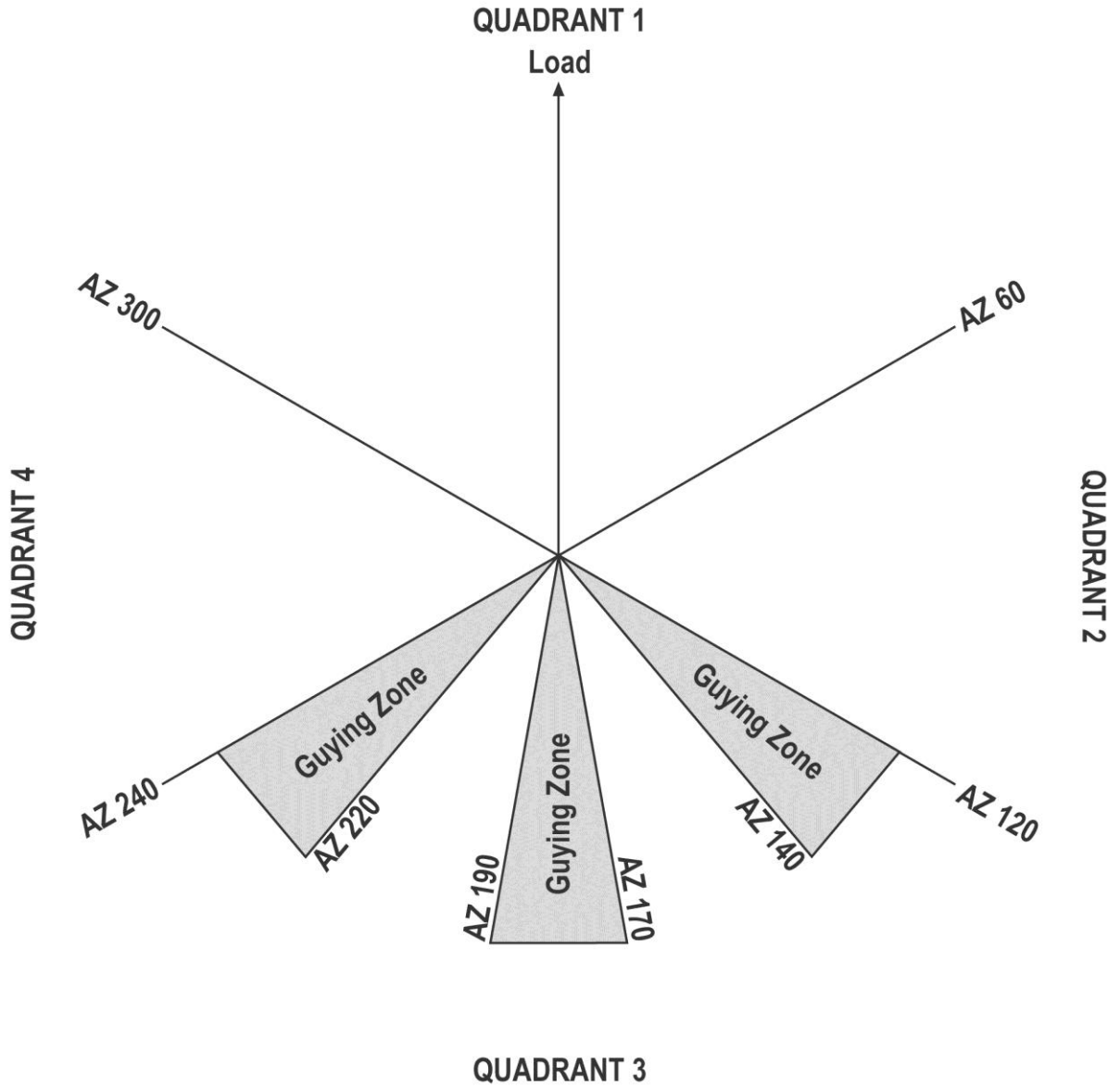

Figure 7-41 - 3 Guyline Case

Appendix 7-I (Mandatory)

Guyline Positioning

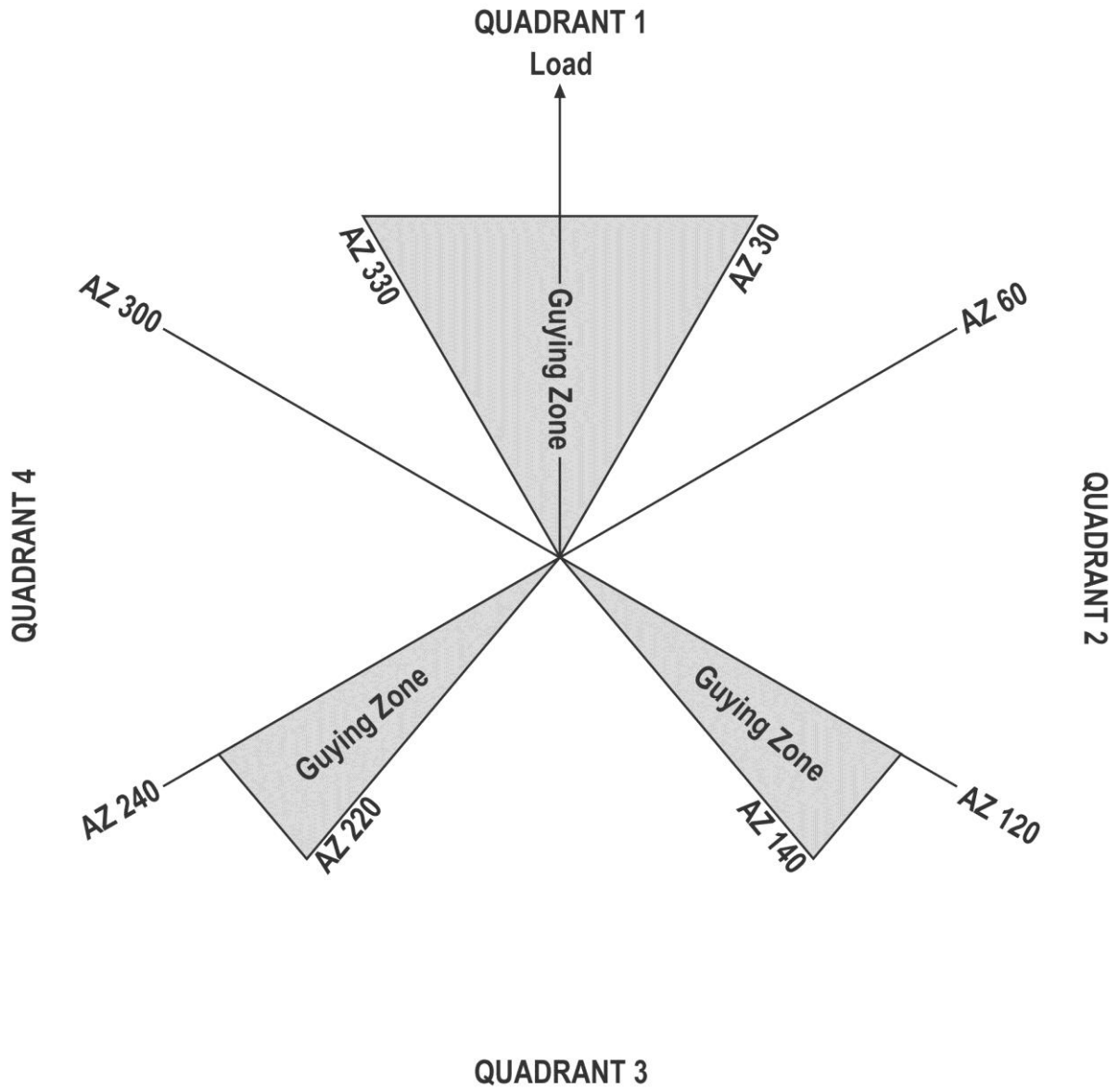

Figure 7-42 – 3 Guyline Case

Appendix 7-I (Mandatory)

Guyline Positioning

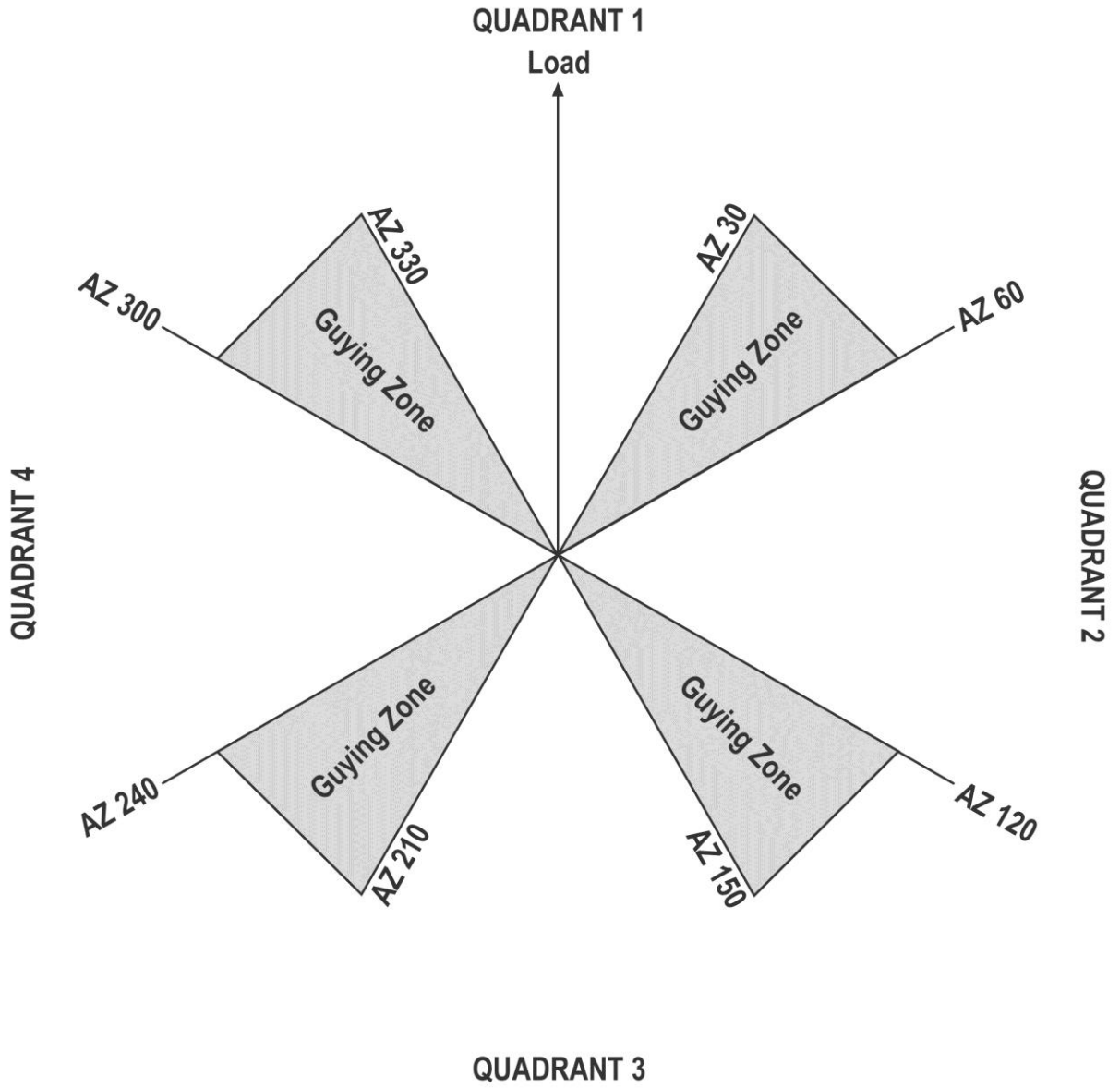

Figure 7-43 – 4 Guyline Case

Appendix 7-I (Mandatory)

Guyline Positioning

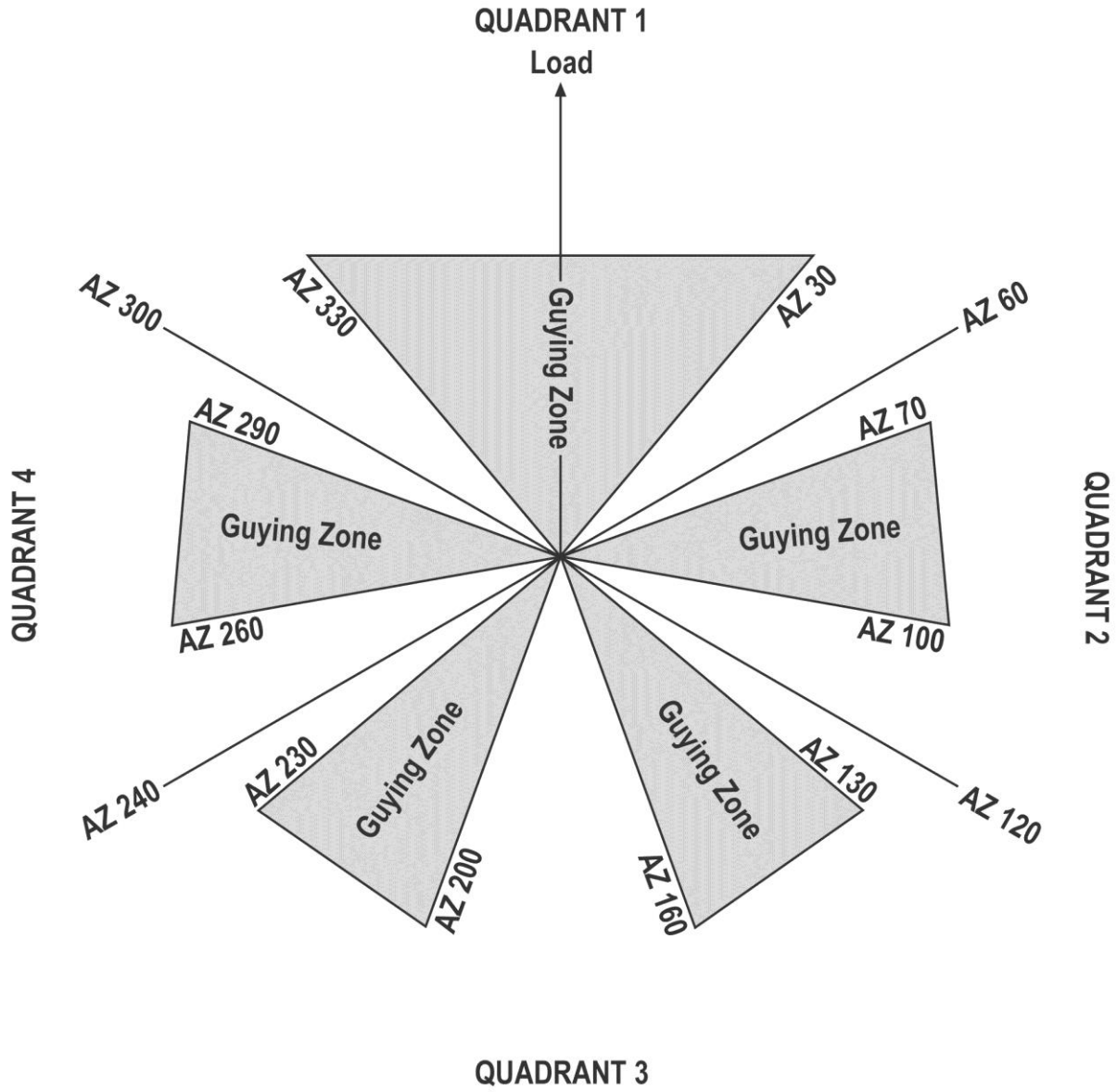

Figure 7-44 – 5 Guyline Case

Appendix 7-I (Mandatory)

Guyline Positioning

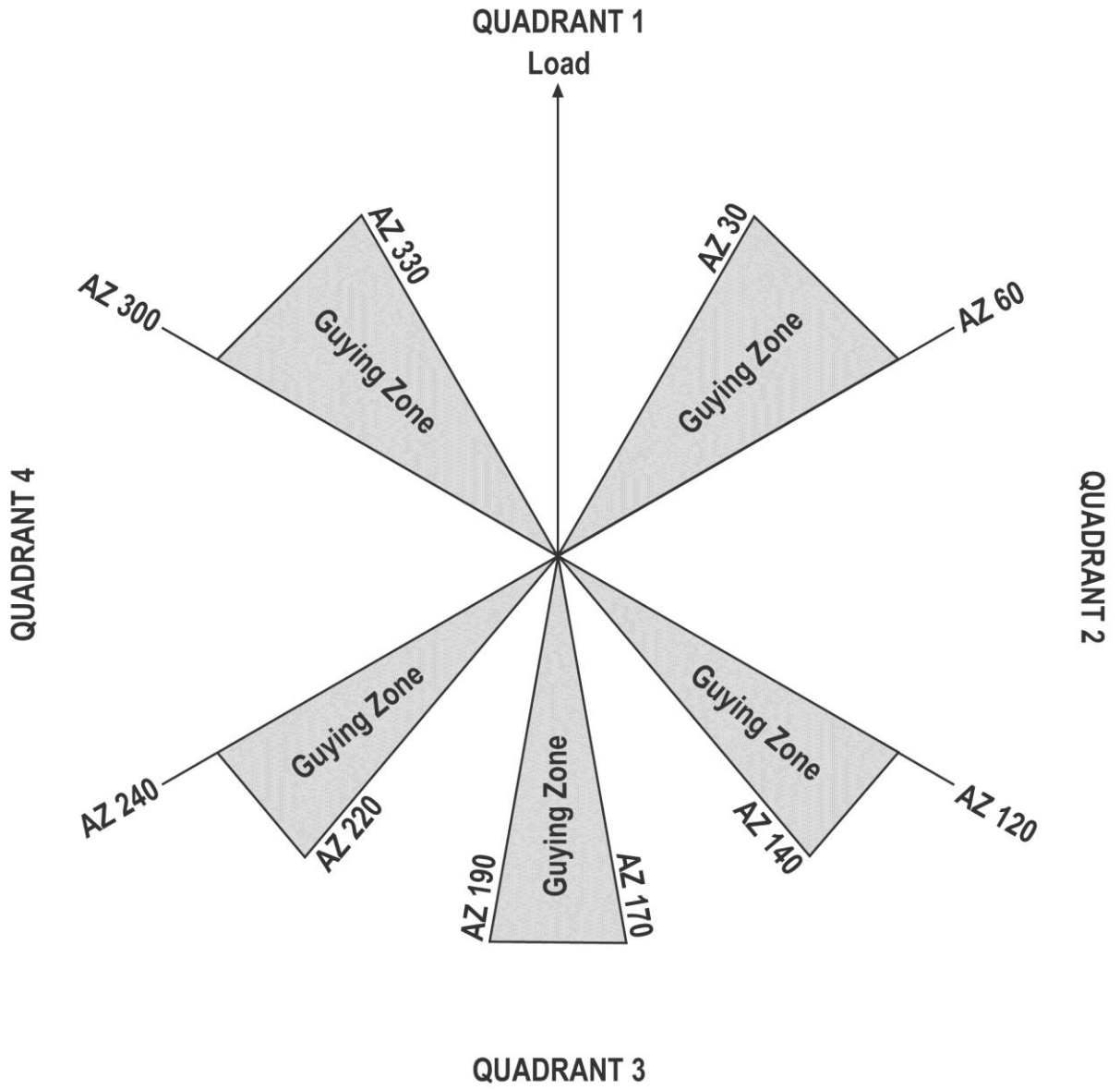

Figure 7-45 – 5 Guyline Case

Appendix 7-I (Mandatory)

Guyline Positioning

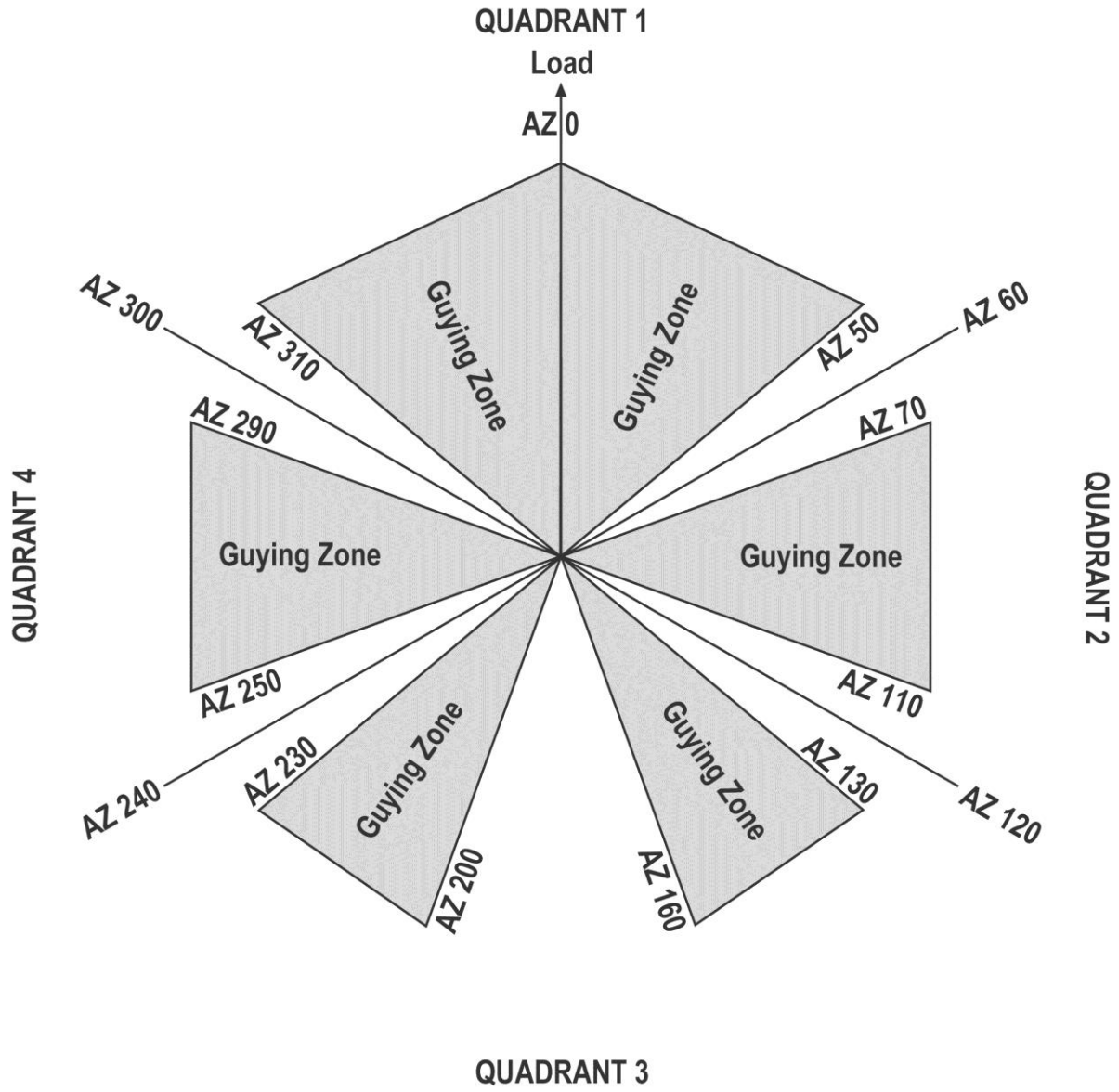

Figure 7-46 – 6 Guyline Case

Appendix 7-I (Mandatory)

Guyline Positioning

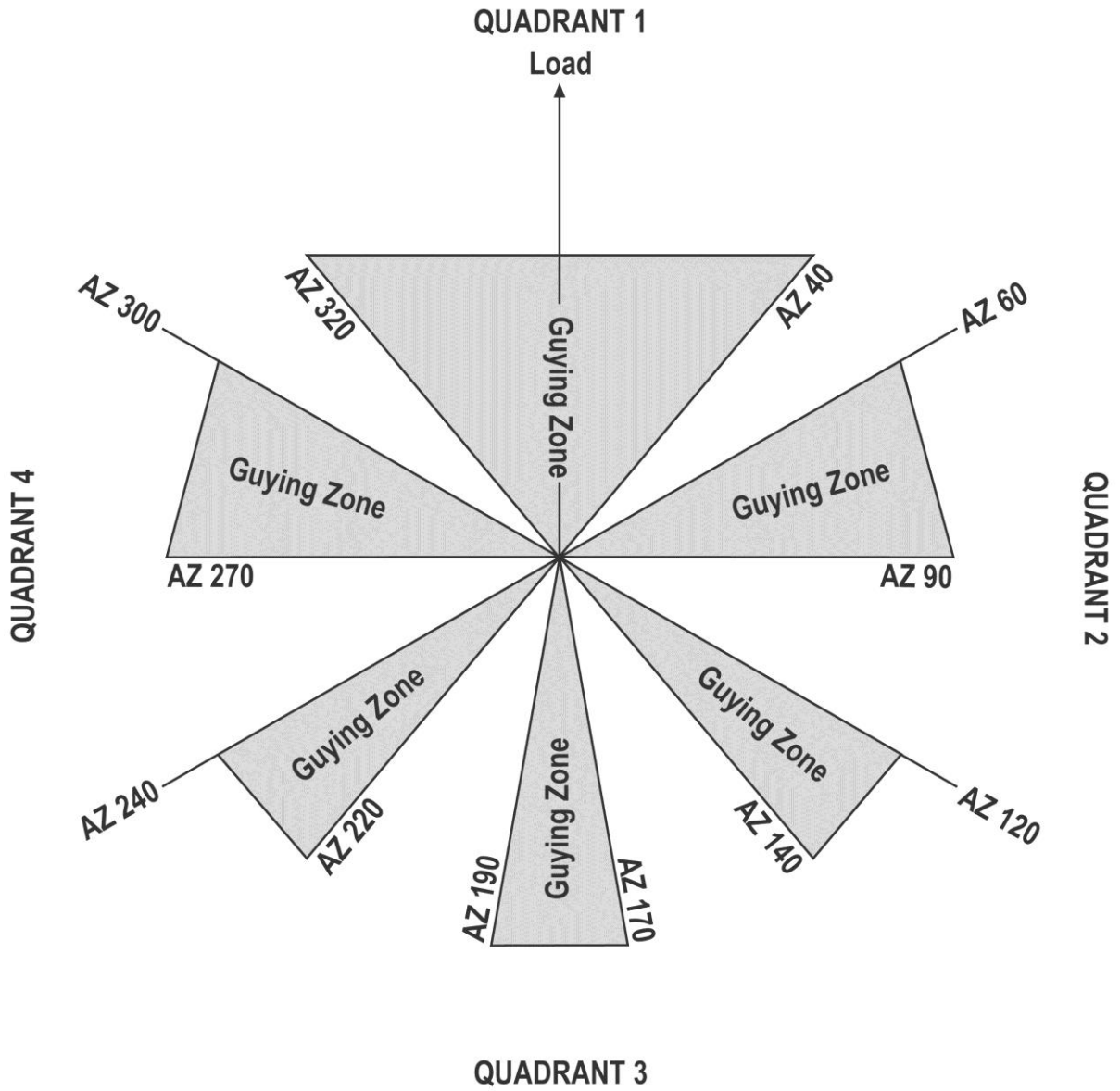

Figure 7-47 – 6 Guyline Case

Appendix 7-I (Mandatory)

Guyline Positioning

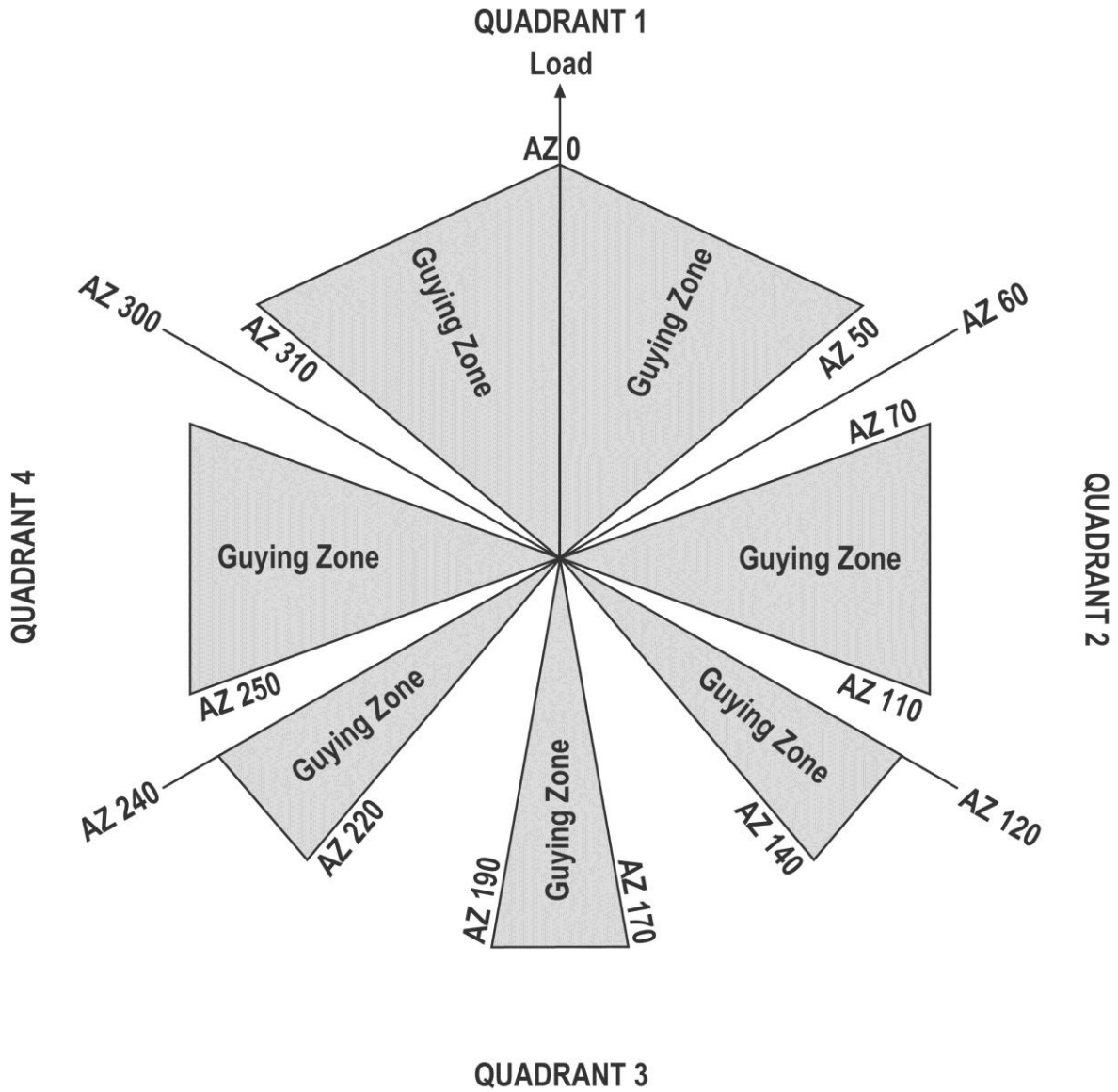

Figure 7-48 – 7 Guyline Case

Appendix 7-I (Mandatory)

Guyline Positioning

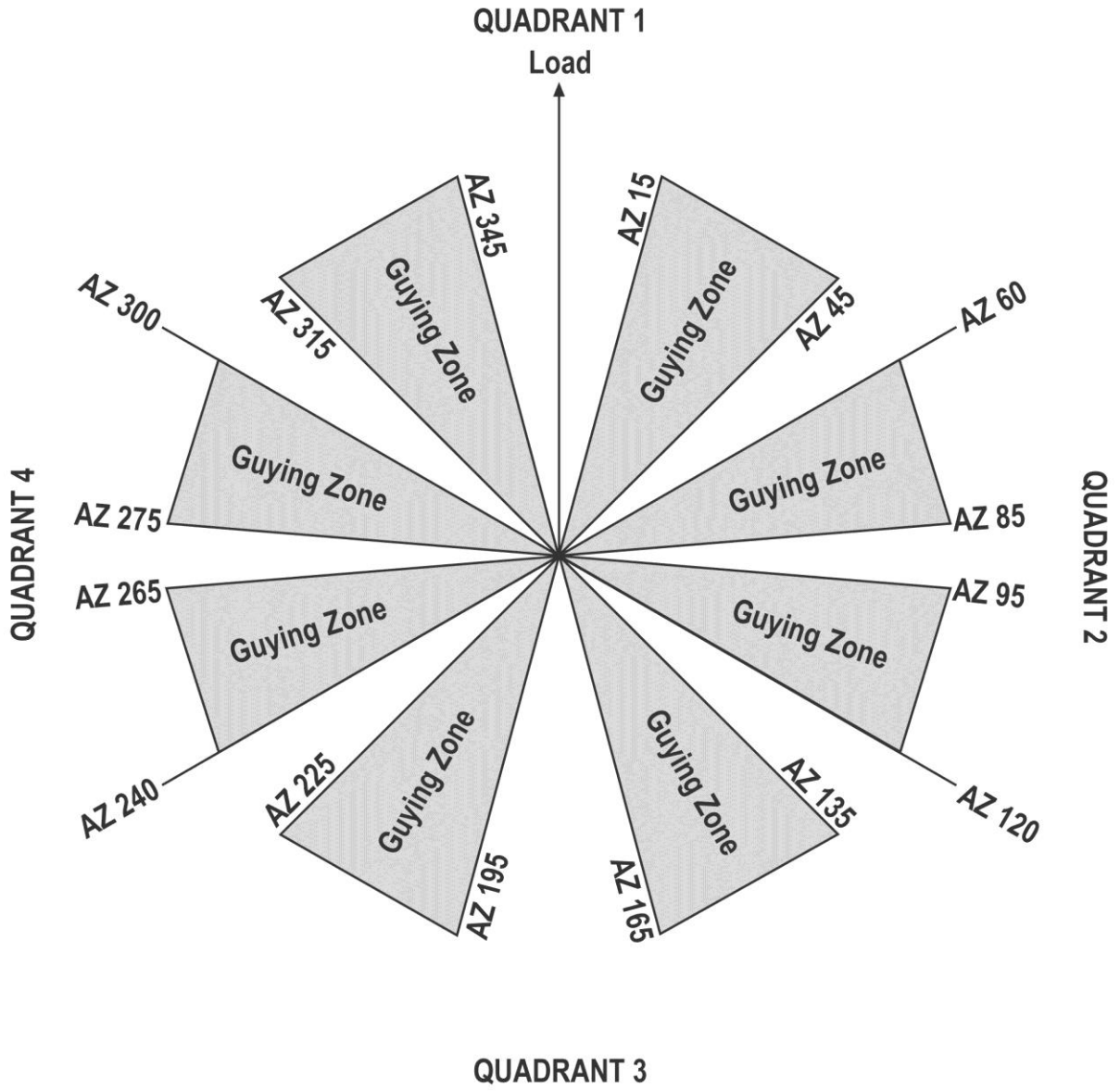

Figure 7-49 – 8 Guyline Case

Appendix 7-I (Mandatory)

Guyline Positioning

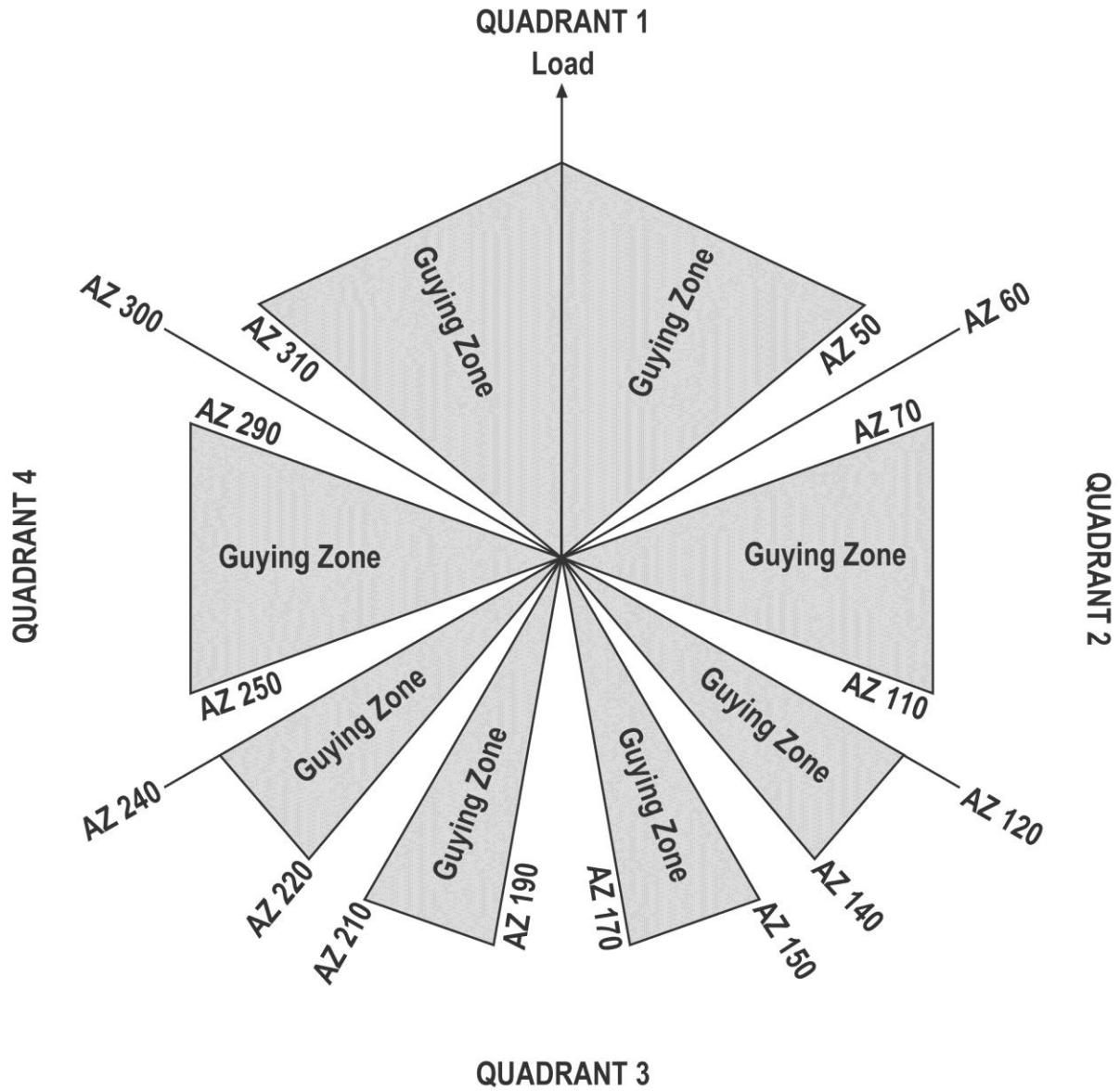

Figure 7-50 – 8 Guyline Case

Stat. Auth.: ORS 654.025(2) and 656.726(4).  
Stats. Implemented: ORS 654.001 through 654.295.  
Hist: OR-OSHA Admin. Order 5-2003, f. 6/02/03, ef. 12/01/03.

Appendix 7-J

Standard Hand Signals

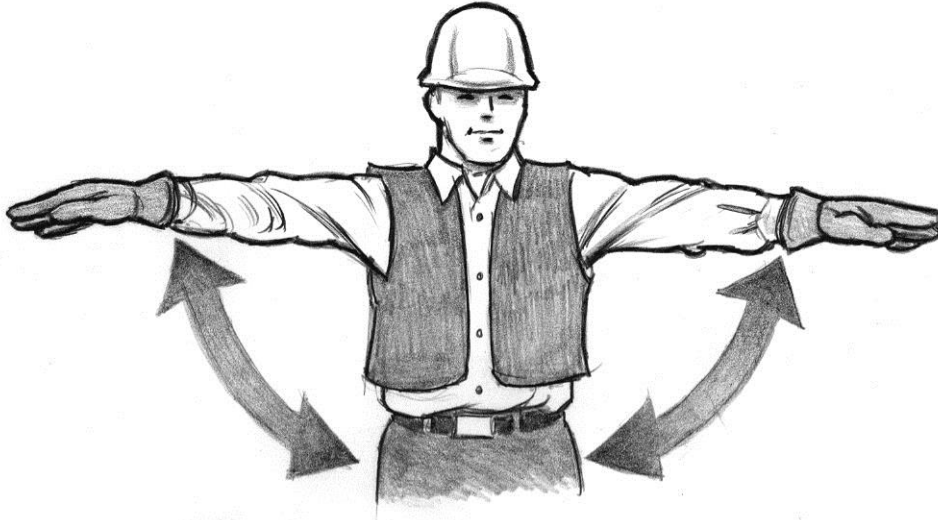

Figure 7-51 – Stop Any Moving Line and Hold  
(Raise both arms)



Figure 7-52 – Mainline Ahead Slow  
(Both arms raised)

Appendix 7-J

Standard Hand Signals



Figure 7-53 – Mainline Ahead Normal  
(Raise one arm)



Figure 7-54 – Mainline Ahead  
(One arm raised, hand fluttering)

Appendix 7-J

Standard Hand Signals



**Figure 7-55 – Slack the Mainline Easy**  
(Both hands extended at side, hands fluttering)



**Figure 7-56 – Slack Mainline All Off**  
(Arm extended at side, flipping wrist)

Appendix 7-J

Standard Hand Signals



Figure 7-57 – Ahead On The Dropline  
(Cross arms in front)



Figure 7-58 – Tightline  
(Hands over head – fingertips touching)

Appendix 7-J

Standard Hand Signals

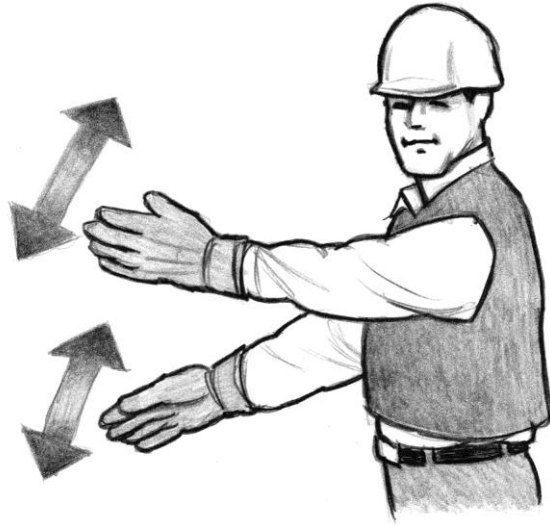

**Figure 7-59 – Slack the Haulback  
(Hand in front of body using chopping motion)**



**Figure 7-60 – Ahead On The Haywire  
(Touch hand to bent elbow)**

**Appendix 7-J**

**Standard Hand Signals**

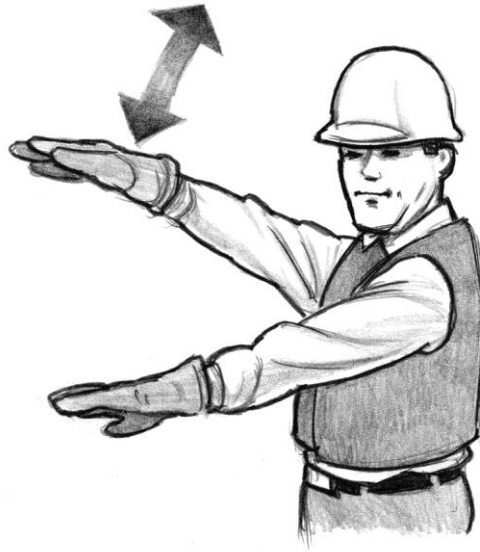

**Figure 7-61 – Slack The Haywire**  
(Pat back of hand with other hand)



**Figure 7-62 – Cable Up**  
(Touch top of head and raise hand up and down)

## Appendix 7-J

### Standard Hand Signals



**Figure 7-63 – Hold, Dog Drum or Brake Lever  
(Clasp one hand with the other)**

**Stat. Auth.:** ORS 654.025(2) and 656.726(4).  
**Stats. Implemented:** ORS 654.001 through 654.295.  
**Hist:** OR-OSHA Admin. Order 5-2003, f. 6/02/03, ef. 12/01/03.



## Appendix 7-K (Mandatory)

### Forest Activities Tree Climbing

#### Belayed (Snubbing) Climbing System

- (1) Single tree anchors used for a ground belay system must be:
  - (a) Straight sided or the belay line located above extreme butt swell, and
  - (b) At least 12 inches in diameter and free of rot.
- (2) When an adequate single tree anchor is not available for a ground belay system, use multiple smaller boles with a self-equalizing anchor system.
- (3) Locate ground belay climbing system anchor(s) so the belayer is:
  - (a) In the clear of falling object(s), and
  - (b) Able to attend the climber at all times.
- (4) Climbers and belayers must:
  - (a) Be in constant communication with each other, and
  - (b) Know and use agreed-on signals.
- (5) The belayer must attend to the climber at all times until the climber signals “off belay.”
- (6) The belayer’s brake hand must not be taken off the rope when a climber is on belay.
- (7) The belayer must be able to secure the belay at all times.

#### Belay Voice Signals

Both climber and belayer must use an agreed upon sequence of signals, commands, and reactions for a smooth, safe climb. The following is an example of signals that could be used:

**Climber:** “On belay” Meaning: I am about to climb. Are you ready to arrest my fall?

**Belayer:** “Belay on” Meaning: I am ready to arrest your fall.

**Climber:** “Climbing” Meaning: I am starting to climb.

**Belayer:** “Climb” Meaning: Go ahead.

## Appendix 7-K (Mandatory)

### Forest Activities Tree Climbing

Once a climber is at a location where a belay is no longer needed:

**Climber:** “Off belay” Meaning: I am in a secure place and no longer need a belay.

**Belayer:** “Belay off” Meaning: I am no longer belaying you.

Some additional signals can assist communication between the climber and belayer. None of these signals requires a verbal response from the belayer, only the action asked for by the climber.

**Climber:** “Slack” Meaning: There is too much tension on the rope, feed me some rope.

**Climber:** “Take in” Meaning: There is too much slack in the rope. Belayer needs to take some rope away from the climber.

**Climber:** “Tension!” Meaning: Take up all slack and hold the rope tightly until I signal differently.

**Climber:** “Falling!” Meaning: I am falling. Prepare to receive my full weight.

In the event that the belayer has problems and cannot maintain the belay:

**Belayer:** “Secure” Meaning: I cannot maintain the belay. Secure a lanyard around the tree and attach the lanyard to the safety harness.

**Climber:** “Secured” Meaning: I have secured a lanyard and am in a safe position.

If a belay is lost, the belayer should reestablish the belay or secure the belay rope to a firm anchor as quickly as possible. The climber and belayer should discuss the situation and take appropriate action. Appropriate action may include terminating the climb.

**Stat. Auth.:** ORS 654.025(2) and 656.726(4).

**Stats. Implemented:** ORS 654.001 through 654.295.

**Hist:** OR-OSHA Admin. Order 3-2008, f. 3/7/08, ef. 7/1/08.